



This is a digital copy of a book that was preserved for generations on library shelves before it was carefully scanned by Google as part of a project to make the world's books discoverable online.

It has survived long enough for the copyright to expire and the book to enter the public domain. A public domain book is one that was never subject to copyright or whose legal copyright term has expired. Whether a book is in the public domain may vary country to country. Public domain books are our gateways to the past, representing a wealth of history, culture and knowledge that's often difficult to discover.

Marks, notations and other marginalia present in the original volume will appear in this file - a reminder of this book's long journey from the publisher to a library and finally to you.

Usage guidelines

Google is proud to partner with libraries to digitize public domain materials and make them widely accessible. Public domain books belong to the public and we are merely their custodians. Nevertheless, this work is expensive, so in order to keep providing this resource, we have taken steps to prevent abuse by commercial parties, including placing technical restrictions on automated querying.

We also ask that you:

- + *Make non-commercial use of the files* We designed Google Book Search for use by individuals, and we request that you use these files for personal, non-commercial purposes.
- + *Refrain from automated querying* Do not send automated queries of any sort to Google's system: If you are conducting research on machine translation, optical character recognition or other areas where access to a large amount of text is helpful, please contact us. We encourage the use of public domain materials for these purposes and may be able to help.
- + *Maintain attribution* The Google "watermark" you see on each file is essential for informing people about this project and helping them find additional materials through Google Book Search. Please do not remove it.
- + *Keep it legal* Whatever your use, remember that you are responsible for ensuring that what you are doing is legal. Do not assume that just because we believe a book is in the public domain for users in the United States, that the work is also in the public domain for users in other countries. Whether a book is still in copyright varies from country to country, and we can't offer guidance on whether any specific use of any specific book is allowed. Please do not assume that a book's appearance in Google Book Search means it can be used in any manner anywhere in the world. Copyright infringement liability can be quite severe.

About Google Book Search

Google's mission is to organize the world's information and to make it universally accessible and useful. Google Book Search helps readers discover the world's books while helping authors and publishers reach new audiences. You can search through the full text of this book on the web at <http://books.google.com/>

B 466590

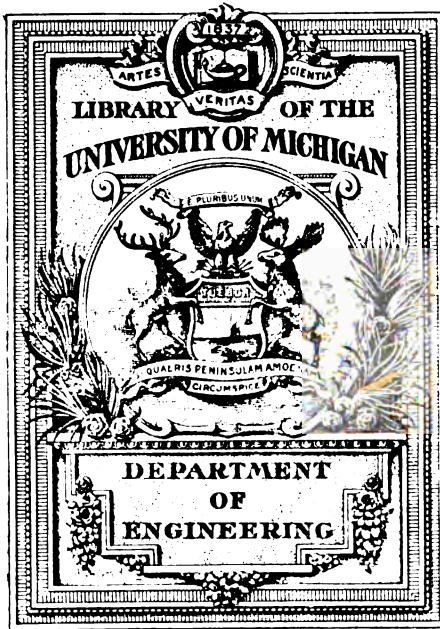

ENGINEERING
LIBRARY

TK

5

.I61

1893



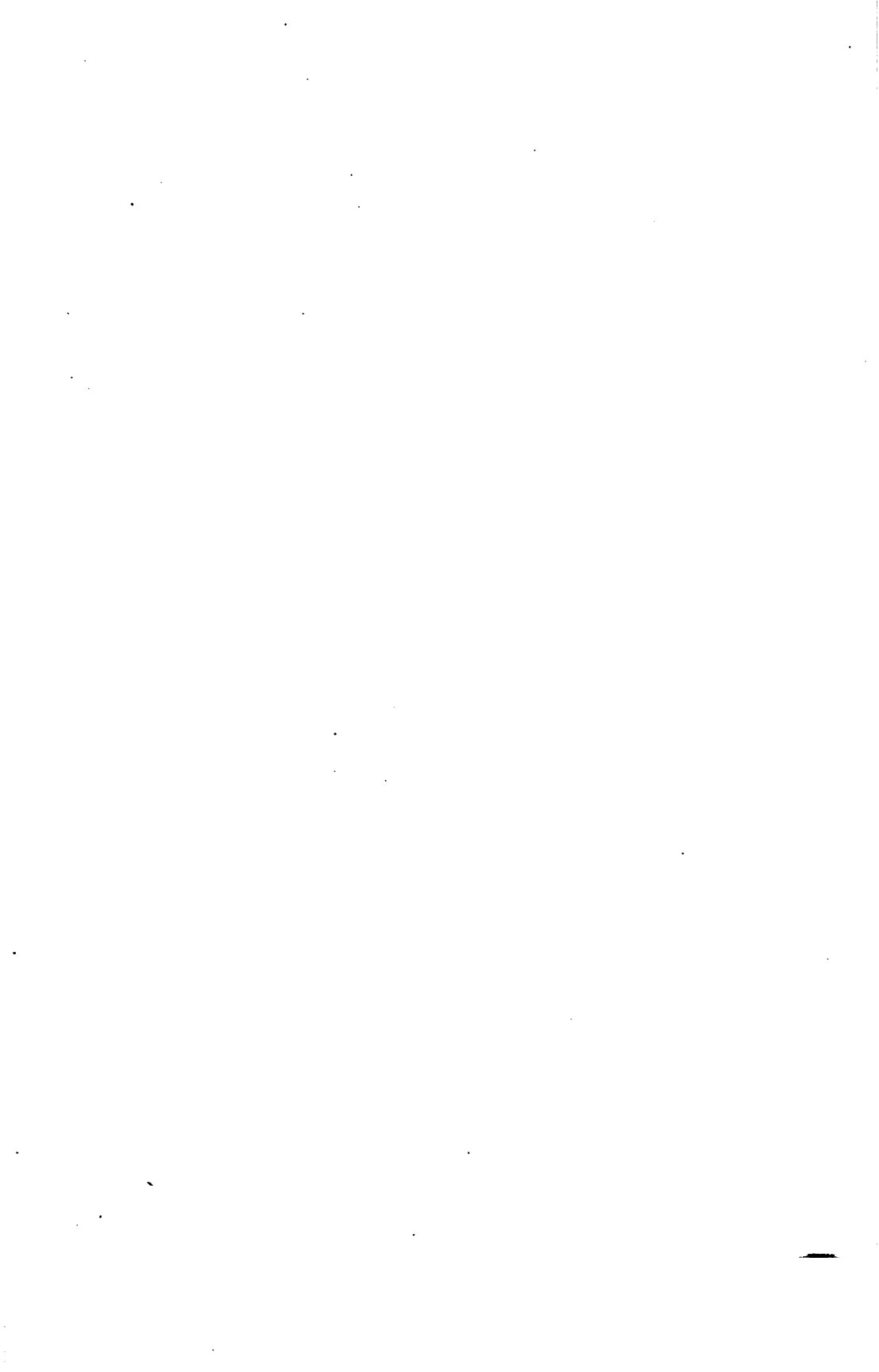

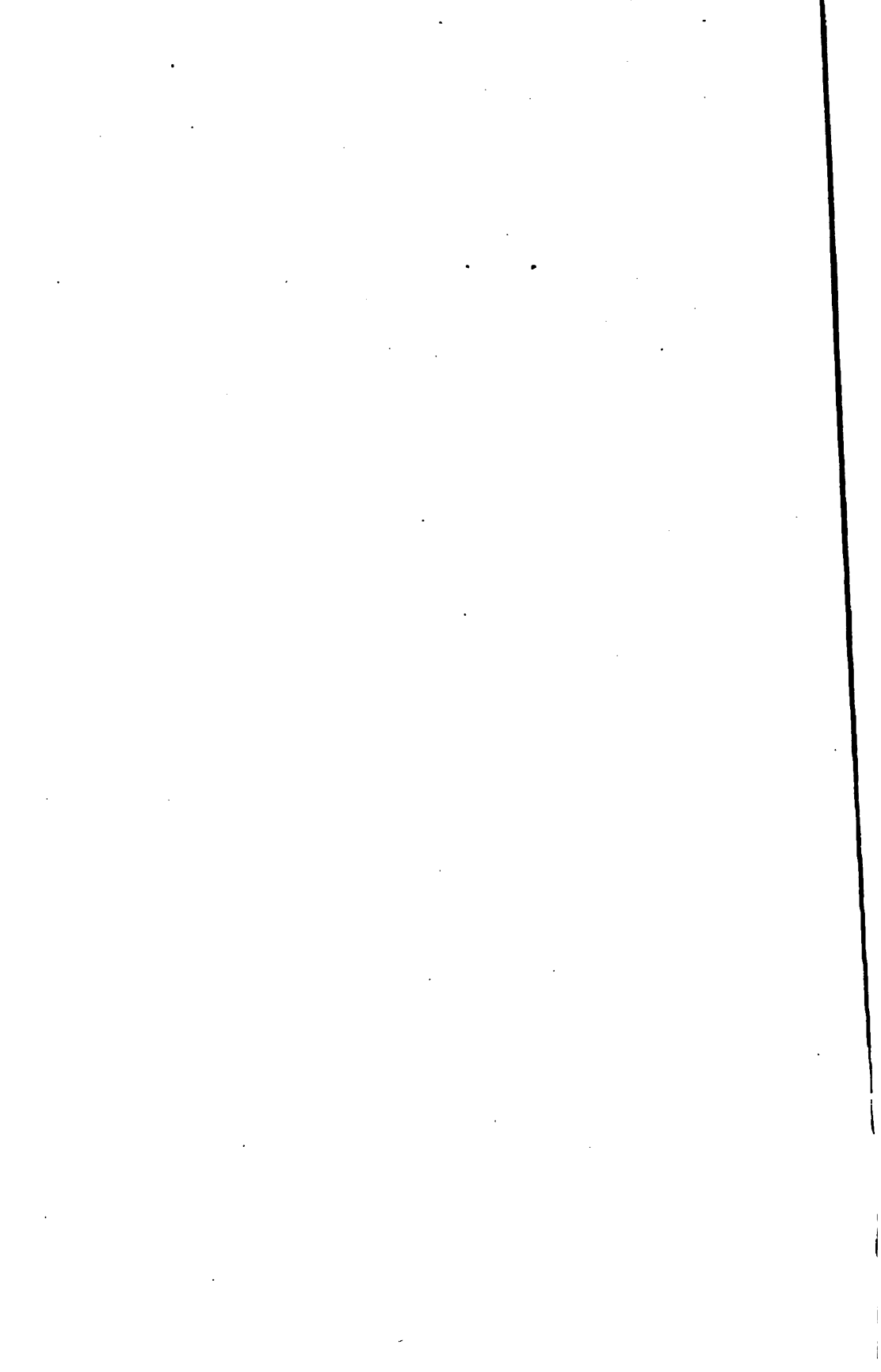



BLUDE	SIEMENS	LEDUC	NICHOLS	WENNMAN	THURY
FERRARIS	SCHÄDER	DE LA TOUAINNE	PALAZ	HOSPITALER	CARHART
LUMMER	VOIT	PREECE	MASCART	ROWLAND	S. P. THOMPSON
	AVRTON	VON HELMHOLTZ			E. THOMPSON
					MENDENHALL

THE OFFICIAL DELEGATES

ROCHELLE

THE CITY OF

THE CITY OF

THE CITY OF

PUBLISHED BY
AMERICAN INSTITUTE OF GRAPHICAL DESIGNERS
12 WEST 57th STREET, NEW YORK, U.S.A.
1934

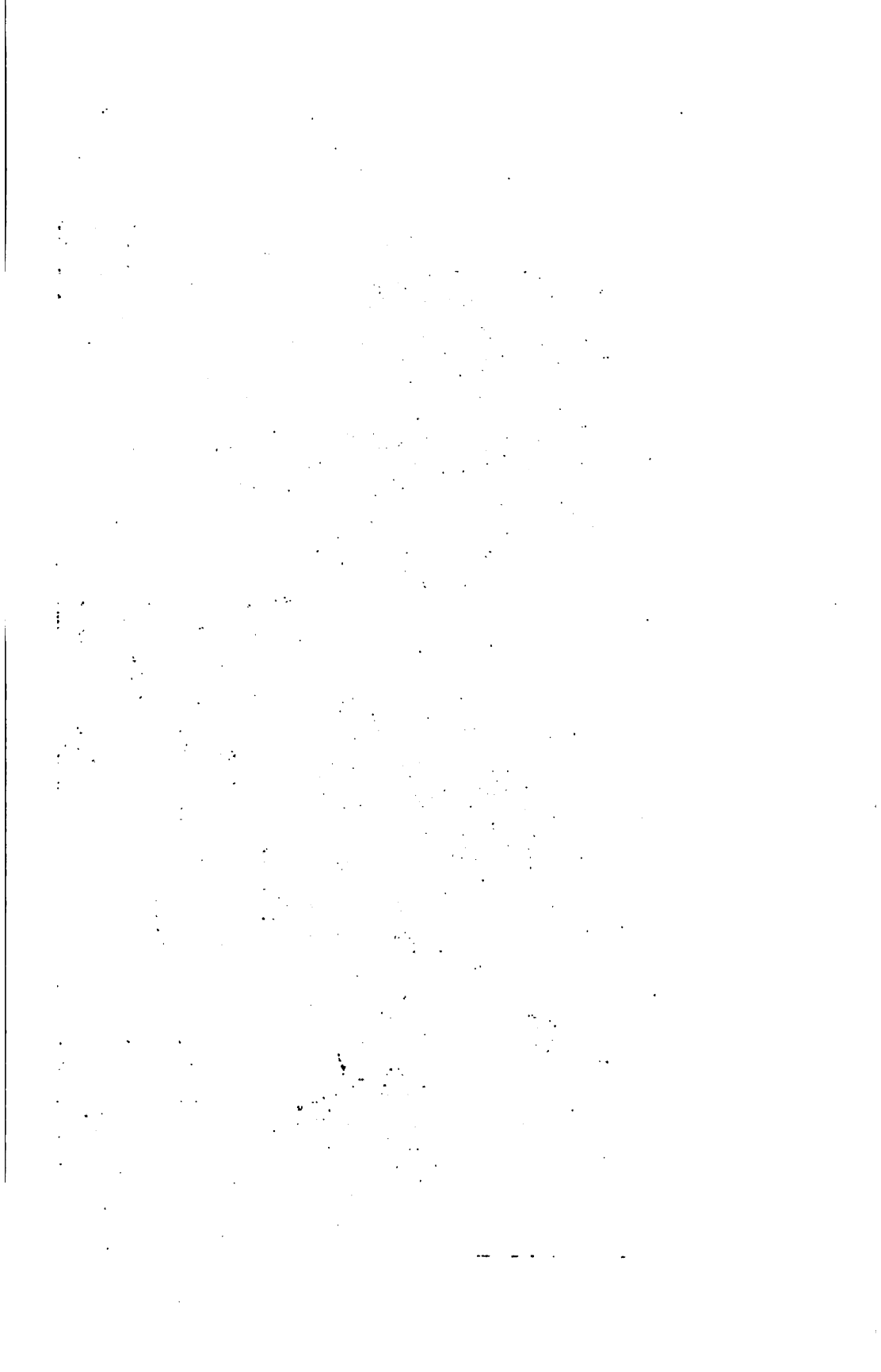

PROCEEDINGS

OF THE

INTERNATIONAL ELECTRICAL CONGRESS

HELD IN

THE CITY OF CHICAGO.

AUGUST 21ST TO 25TH, 1893.

PUBLISHED BY THE
AMERICAN INSTITUTE OF ELECTRICAL ENGINEERS,
12 WEST 31ST STREET, NEW YORK, U. S. A.

—1894—

Copyright, 1894, by the
AMERICAN INSTITUTE OF ELECTRICAL ENGINEERS.

Press of McIlroy & Emmet, 36 Cortlandt St., N. Y.

PROCEEDINGS
OF THE
INTERNATIONAL ELECTRICAL CONGRESS,
HELD IN CHICAGO, 1893.

PUBLICATION COMMITTEE REPRESENTING
THE AMERICAN INSTITUTE OF ELEC-
TRICAL ENGINEERS:

GEO. M. PHELPS, *Chairman*,
A. E. KENNELLY,
FRANCIS B. CROCKER.

PUBLICATION COMMITTEE OF THE
INTERNATIONAL ELECTRICAL CON-
GRESS:

FRANCIS B. CROCKER, *Chairman*.
CARL HERING,
A. E. KENNELLY.

RALPH W. POPE, *Secretary*,

MAX OSTERBERG, *Editor*.



PRELIMINARY ORGANIZATION.

ELECTRICAL CONGRESS COMMITTEE OF THE WORLD'S COLUMBIAN EXPOSITION.

DR. ELISHA GRAY,
Chairman.

COL. R. C. CLOWRY,
Vice-Chairman.

PROF. H. S. CARHART,
Secretary.

ADVISORY COUNCIL.

Sir William Thomson, F. R. S. (Lord Kelvin)
Glasgow, Scotland.
Wm. H. Preece, F. R. S., London, England.
Prof. W. E. Ayrton, F. R. S., London, England.
Lord Rayleigh, England.
Prof. S. P. Thompson, D. Sc., London, England.
Prof. E. Mascart, Paris, France.
E. Hospitalier, Paris, France.
Dr. Werner Siemens, Berlin, Germany.
Prof. H. von Helmholtz, Berlin, Germany.
Prof. Galileo Ferraris, Turin, Italy.
Joseph Kereis, Austria.
Prof. Dr. H. F. Weber, Zurich, Switzerland.
Prof. E. Gerard, Liège, Belgium.
Prof. A. Repman, Moscow, Russia.
Prof. A. Stoletow, Moscow, Russia.
S. Yalas, City of Mexico, Mexico.
Director General of Telegraphs, Madrid, Spain.
Prof. Geo. F. Barker, M. D., Philadelphia, Pa.
Prof. C. F. Brackett, Princeton, N. J.
Prof. Henry A. Rowland, Baltimore, Md.
Prof. T. C. Mendenhall, L. L. D., Washington,
D. C.
Prof. B. F. Thomas, Columbus, Ohio.
Prof. Thomas Gray, Terre Haute, Indiana.
Prof. A. E. Dolbear, College Hill, Mass.
Prof. John Trowbridge, D. Sc., Cambridge,
Mass.
Prof. F. E. Nipher, St. Louis, Mo.
Prof. Sidney H. Short, Cleveland, Ohio.

Prof. Henry Morton, Hoboken, N. J.
Prof. Brown Ayres, New Orleans, La.
Prof. John E. Davies, L. L. D., Madison, Wis.
Prof. A. P. Carman, Lafayette, Ind.
Prof. Lucien-L. Blake, Ph. D., Lawrence, Kan.
Charles F. Brush, Cleveland, Ohio.
Dr. Channing, Pasadena, Cal.
Prof. M. I. Pupin, Ph. D., New York, N. Y.
Prof. Elihu Thomson, Lynn, Mass.
Franklin L. Pope, Elizabeth, N. J.
George M. Phelps, New York, N. Y.
Frank J. Sprague, New York, N. Y.
Edward Weston, Newark, N. J.
Prof. Wm. A. Anthony, New York, N. Y.
Louis Duncan, Ph. D., Baltimore, Md.
Prof. Alex. Graham Bell, Washington, D. C.
Prof. Francis B. Crocker, New York, N. Y.
Nikola Tesla, New York, N. Y.
Thomas A. Edison, Ph. D., Orange, N. J.
Carl Hering, Philadelphia, Pa.
T. Commerford Martin, New York, N. Y.
Prof. Edward L. Nichols, Ph. D., Ithaca, N. Y.
Prof. Edwin J. Houston, Philadelphia, Pa.
Dr. William E. Geyer, Hoboken, N. J.
A. E. Kennelly, Philadelphia, Pa.
Thomas D. Lockwood, Boston, Mass.
Louis Bell, Ph. D., Chicago, Ill.
Prof. Chas. R. Cross, Boston, Mass.
George A. Hamilton, Elizabeth, N. J.
Ralph W. Pope, Elizabeth, N. J.

EXECUTIVE COMMITTEE.

PROF. B. F. THOMAS, Chairman. PROF. ELIHU THOMSON. E. M. BARTON.
G. M. PHELPS. F. S. TERRY.

FINANCE COMMITTEE.

W. A. KREIDLER, Chairman. B. E. SUNNY. PROF. E. J. HOUSTON.

PROGRAMME AND PAPERS COMMITTEE.

PROF. T. C. MENDENHALL, Chairman. PROF. H. A. ROWLAND.
PROF. H. S. CARHART. CARL HERING. A. E. KENNELLY.
PROF. W. A. ANTHONY. PROF. F. B. CROCKER. PROF. E. L. NICHOLS.

INVITATIONS COMMITTEE.

C. H. WILMERDING, Chairman. T. C. MARTIN. DR. LOUIS DUNCAN.
PROF. CHAS. R. CROSS. T. D. LOCKWOOD.

PERMANENT ORGANIZATION.

HONORARY PRESIDENT :

HIS EXCELLENCY DR. HERMANN VON HELMHOLTZ, of Berlin.

PERMANENT CHAIRMAN:

DR. ELISHA GRAY, of Chicago.

VICE-PRESIDENTS :

EDWARD WESTON, United States,	W. H. PREECE, F. R. S., Great Britain.
PROF. E. MASCART, France,	DR. J. SAHULKA, Austria,
PROF. GALILEO FERRARIS, Italy,	M. WENNMAN, Sweden,
PROF. A. PALAZ, Switzerland,	ORMOND HIGMAN, British North America.
A. W. CHAVEZ, Mexico,	

PERMANENT SECRETARY :

PROF. FRANCIS B. CROCKER, of New York.

CHAMBER OF OFFICIAL DELEGATES :

President: PROF. H. A. ROWLAND, of Baltimore, Md.

Secretary: PROF. E. L. NICHOLS, of Ithaca, N. Y.

Representing the United States: PROF. H. A. ROWLAND ; DR. T. C. MENDENHALL ; PROF. H. S. CARHART ; PROF. ELIHU THOMSON ; DR. E. L. NICHOLS.

Great Britain: W. H. PREECE, F. R. S. ; PROF. W. E. AYRTON ; PROF. S. P. THOMPSON ; ALEXANDER SIEMENS.

France: PROF. E. MASCART ; PROF. T. VIOLLE ; M. DE LA TOUANNE ; PROF. E. HOSPITALIER ; DR. S. LEDUC.

Germany: DR. H. VON HELMHOLTZ ; DR. E. BUDDE ; A. SCHRÄDER ; DR. ERNST VOIT ; DR. OTTO LUMMER.

Italy: PROF. GALILEO FERRARIS.

Austria: DR. J. SAHULKA.

Switzerland: PROF. A. PALAZ ; REVÉ THURY.

Sweden: M. WENNMAN.

Mexico: A. W. CHAVEZ.

British North America: ORMOND HIGMAN.

SECTION A.

Chairman : PROF. H. A. ROWLAND,

Secretary : PROF. A. L. KIMBALL.

SECTION B.

Chairman : PROF. CHARLES R. CROSS,

Secretary : LIEUT. S. REBER.

SECTION C.

Chairman : PROF. EDWIN J. HOUSTON,

Secretary : PROF. E. P. ROBERTS.

PUBLICATION COMMITTEE :

PROF. F. B. CROCKER, *Chairman*,

CARL HERING,

A. E. KENNELLY,

PRESS REPRESENTATIVE :

RALPH W. POPE,

ENTERTAINMENT COMMITTEE :

RALPH W. POPE, *Chairman*,

• W. E. ANDERSON,

J. ALLEN HORNSBY.

MEMBERS OF THE CONGRESS.

Abbott, A. V.	Flood S. D.	Owens, R. B.
Anderson, W. E.	Foster, H. A.	Page, Chas. T.
Anthony, W. A.	Frick, Otto	Patterson, Geo W., Jr
Ayer, Jas. I.	Gray, Elisha	Perkins, F. C.
Ayres, Brown	Guerreiro, J. V. Mendes	Perrine, F. A. C.
Babo, Alex. von	Hamilton, Geo. A.	Perry, D. P.
Badt, F. B.	Hayes, H. I.	Perry, Nelson W.
Baker, W. E.	Heaviside, A. W.	Phelps, Geo. M.
Baker, Jr., C. O.	Heinrich, R. O.	Pollak, C.
Baldwin, O. H.	Heinrichs, Dr. G.	Pope, R. W.
Bayles, R. N.	Hering, Carl	Powers, E. L.
Beach, F. G.	Hering, Herman S.	Reber, Lieut.
Bedell, Frederick	Hewitt, Edw. R.	Reed, Henry A.
Bernard, E. G.	Higman, A. E.	Requa, Harry L.
Blake, Eli W.	Horne, F. W.	Richardson, R. E.
Bliss, Geo. H.	Hornsby, J. Allan	Robbe, Wm. L.
Blodgett, George W.	Houston, E. J.	Roberts, E. P.
Braddell, A. E.	Insull, Samuel	Rogers, H. R.
Bradley, Chas. S.	Jackson, Dugald C.	Rotch, A. L.
Brown, Chas. E.	Jamieson, Andrew	Rowland, H. A.
Budde, Dr.	Johnston, W. J.	Schrader, Wm.
Burnett, Douglass	Jones, A. J.	Schulze-Berge, F.
Caldwell, Edward	Jones, F. W.	Shippy, Henry L.
Carhart, H. S.	Keith, N. S.	Short, Sidney H.
Carpmael, C.	Kennelly, A. E.	Smith, Francis H.
Clowry, R. C.	Khotinsky, de A.	Smith, Jesse M.
Collins, W. Forman	Kimball, A. L.	Spencer, Lieut. E. J.
Crehore, Dr.	Lemp, Hermann	Sperry, Elmer A.
Crocker, Francis B.	Lemstrom, Selim	Steinmetz, C. P.
Cross, Chas. R.	Lindeck, Stephan	Stubbs, Will C.
Cutter, Geo.	Lobach, Walter	Summers, C. H.
Cuttriss, Chas.	Lockwood, T. D.	Summers, L. L.
Cushman, Holbrook	Low, George P.	Sunny, B. E.
Davies, Prof.	Lowry, C. D.	Terry, F. S.
Dee, Jas. R.	Macfarlane, Alex.	Thomas, Benj. F.
Dee, Thos. S.	Mailloux, C. O.	Thomson, Elihu
Degenhardt, F. E.	Manning, H. S.	Tischendoerfer, F. W.
DeLand, Fred.	McFarland, G. E.	Voit, Dr.
Dolbear, A. E.	McIntyre, C. H.	Walmsley, R. M.
Doremus, C. A.	McKuillock, Geo. A.	Webster, A. G.
Duncan, Dr. Louis	Mendenhall, T. C.	Wedding, Dr.
Dunn, G. S.	Metcalf, Geo. R.	Weeks, Edwin R.
Edison, Thos. A.	Nichols, E. L.	Weeks, Ramond L
Eickemeyer, R.	O'Dea, M.	Weston, Edwd.
Emery, C. E.	O'Hara, J. B.	Wetzler, Jos.
Ferguson, L. A.	Olivetti, Camillo	Wheeler, S. S.
Ferraris, Galileo	Osterberg, Max	Wilson, C. H.
Feuszner, Dr. Carl	Otis, N. P.	Wolcott, T.

TABLE OF CONTENTS.

OPENING OF CONGRESS.....	1
PROCEEDINGS OF THE CHAMBER OF DELEGATES.....	15
PROCEEDINGS OF SECTION A.....	22
ON THE ANALYTICAL TREATMENT OF ALTERNATING CURRENTS, by Prof. A. Macfarlane.....	24
COMPLEX QUANTITIES AND THEIR USE IN ELECTRICAL ENGINEERING, by Chas. Proteus Steinmetz.....	33
GENERAL DISCUSSION OF THE CURRENT FLOW IN TWO MUTUALLY RELATED CIRCUITS CONTAINING CAPACITY, by Frederick Bedell, Ph. D. and Albert C. Crehore, Ph. D.....	76
EXPLANATION OF THE FERRANTI PHENOMENON, by Dr. J. Sahulka.....	105
MEASUREMENTS OF THE ENERGY OF POLYPHASE CURRENTS, by A. Blondel.....	112
THE EXTENDED USE OF THE NAME RESISTANCE IN ALTERNATING CURRENT PROBLEMS, by Prof. W. E. Ayrton.....	117
PROCEEDINGS OF SECTION B.....	118
SIGNALLING THROUGH SPACE BY MEANS OF ELECTRO MAGNETIC VIBRATIONS.....	119
OCEAN TELEPHONY, by SILVANIUS P. THOMPSON, D. Sc., F. R. S.....	143
MATERIALS FOR WIRE STANDARDS OF ELECTRICAL RESISTANCE, by Dr. Stephan Lindeck.....	165

SOME MEASUREMENTS OF THE TEMPERATURE VARIATION IN THE ELECTRICAL RESISTANCE OF A SAMPLE OF COPPER	183
NOTE ON PHOTOMETRIC MEASUREMENT, by Prof. B. F. Thomas	198
A PAIR OF ELECTROSTATIC VOLTMETERS.....	205
ON A METHOD OF GOVERNING AN ELECTRIC MOTOR FOR CHRONOGRAPHIC PURPOSES.....	212
IRON FOR TRANSFORMERS, by Prof. J. A. Ewing, F. R. S.	216
LONDON ELECTRICAL ENGINEERING LABORATORIES, by Prof. Andrew Jamieson, M. Inst. C. E., F. R. S. E., Etc....	220
TRANSFORMER DIAGRAMS EXPERIMENTALLY DETERMINED, by Dr. Frederick Bedell.....	234
ON AN IMPROVED FORM OF INSTRUMENT FOR THE MEASURE- MENTS OF MAGNETIC RELUCTANCE, by A. E. Kennelly.	252
VARIATION OF P. D. OF THE ELECTRIC ARC WITH CURRENT, SIZE OF CARBONS AND DISTANCE APART, by Prof. W. E. Ayrton, F. R. S.....	258
LIGHT AND HEAT OF THE ELECTRIC ARC, by M. J. Violle.	259
ON THE MAXIMUM EFFICIENCY OF ARC LAMPS WITH CON- STANT WATTS, by Prof. H. S. Carhart.....	270
THE PERIODIC VARIATION OF CANDLE POWER IN ALTERNA- TING ARC LIGHTS, by Benj. F. Thomas, Ph. D.....	273
NEW RESEARCHES ON THE ALTERNATING CURRENT ARC, by A. Blondel.....	279
ON THE CONTINUOUS CURRENT ARC AND ITS EMPLOYMENT AS A PHOTOMETRIC STANDARD, by A. Blondel.....	315
ON THE SOURCE AND EFFECTS OF HARMONICS IN ALTER- NATING CIRCUITS, by H. A. Rowland.....	335
ADJOURNMENT OF SECTION B.....	337
PROCEEDINGS OF SECTION C.....	338
ROTARY MERCURIAL AIR PUMPS, by Dr. F. Schulze-Berge.	342
UNDERGROUND WIRES FOR ELECTRIC LIGHTING AND POWER DISTRIBUTION, by Prof. Dugald C. Jackson.....	356
VARIOUS USES OF THE ELECTROSTATIC VOLTMETER, by Dr. J. Sahulka.....	379

A NEW INCANDESCENT ARC LIGHT, by Louis B. Marks...	387
DIRECT CURRENT DYNAMOS OF VERY HIGH POTENTIAL, by Prof. Francis B. Crocker.....	403
MULTIPHASE MOTORS AND POWER TRANSMISSION, by Dr. Louis Duncan.	411
EXHIBIT OF TESLA POLYPHASE SYSTEM AT THE WORLD'S FAIR, by C. F. Scott.....	417
DISCUSSION ON POWER TRANSMISSION.	
Dr. L. Bell.....	423
Mr. Stillwell.....	428
Prof. S. P. Thompson.....	430
Prof. Forbes.....	433
Mr. C. P. Steinmetz.....	436
A NOVEL METHOD OF TRANSFORMING ALTERNATING INTO CONTINUOUS CURRENTS, by Dr. Charles Pollak.....	438
DISCUSSION ON POWER TRANSMISSION.—Continued.	
Prof. Forbes.....	444
Prof. H. A. Rowland.....	455
Prof. D. C. Jackson.....	458
Dr. L. Bell.....	459
Mr. Charles S. Bradley.....	463
Mr. Charles P. Steinmetz.....	464
Dr. Keith.....	466
Mr. Lemp.....	468
Mr. F. C. Hasson.....	470
Dr. Louis Duncan.....	471
NOTE ON THE VARIATION OF CAPACITY OF INSULATED WIRES WITH TEMPERATURE, by Herman S. Hering.....	473
THE TESLA MECHANICAL AND ELECTRICAL OSCILLATORS...	475
INTERNATIONAL ELECTRICAL CONGRESS BANQUET.....	483
FINAL GENERAL MEETING.....	485

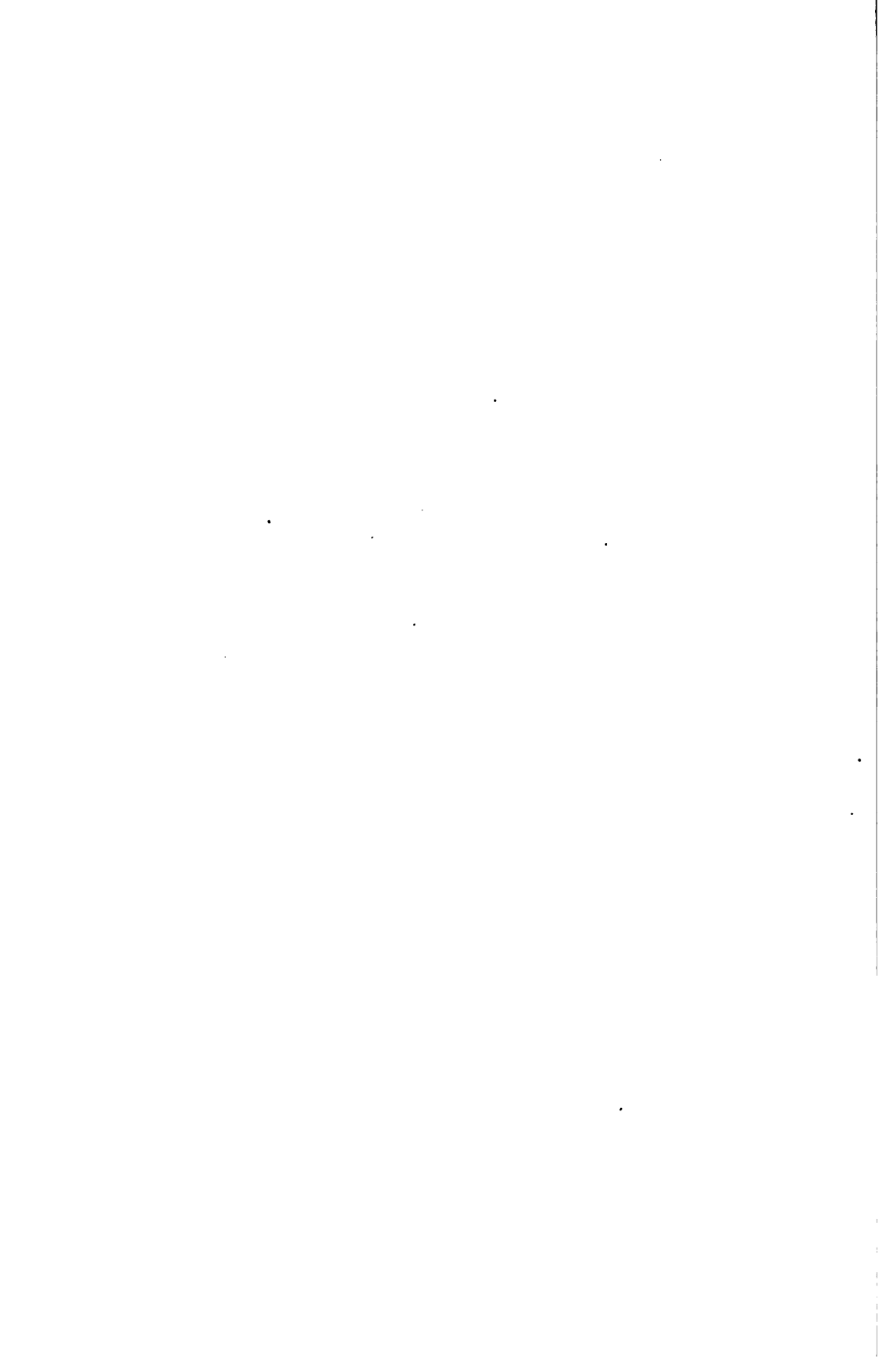

INDEX.

AUTHORS OF PAPERS AND PARTICIPANTS IN DISCUSSIONS.

Ayrton, Prof. W. E.....	6, 16, 17, 18, 19, 117, 257, 258, 484
Bedell, Dr. Fred'k.....	31, 76, 283, 284
Bell, Dr. Louis.....	423, 459
Berresford, A. W.....	284
Blodgett, G. W.....	338, 377
Blondel, A.....	112, 279
Böhm, Dr. L. K.....	231, 353
Bradley, Chas. S.....	463
Budde, Dr.....	16
Caldwell, E.....	338
Carhart, Prof. H. S.....	15, 16, 204, 205, 210, 270, 484
Carrol, Dr.....	157
Craft, W. M.....	234
Crehore, Dr.....	76
Crocker, Prof. Francis B.....	157, 403
Cross, Prof. Chas. R.....	6, 118, 136, 141, 142, 156, 157, 161, 164, 176, 182, 195, 196, 197, 202, 203, 204, 210, 211, 219, 230, 232, 233, 251, 257, 258, 264, 266, 337
Cuttriss, Charles.....	160, 164
Davies, J. E.....	31
De Camp.....	376
Dolbear, Prof. A. E.....	118
Duncan, Dr. Louis.....	118, 411, 471
Emery, Dr. Chas. E.....	140
Ewing, Prof. J. A.....	216
Farnham, I. H.....	372
Ferraris, Prof. Galileo.....	15, 18, 22, 484
Fessenden, Reginald A.....	183
Forbes, Prof. George.....	433, 444
Foster, H. A.....	338
Frick, Otto.....	429, 443
Gherardi, B., Jr.....	234
Gray, Dr. Elisha.....	1, 13, 14, 475, 484, 485, 486

Hasson, W. F. C.....	118, 422, 443, 470
Hayes, H. I.....	158, 232
Heaviside.....	140, 160, 374
Helmholtz, Dr. H. von.....	11, 15, 16, 17, 19, 484, 486
Hering, Carl.....	202
Hering, Hermann S.....	473
Hindricks.....	265
Houston, Prof. E. J.....	338, 340, 341, 355, 368, 369, 378, 386, 399, 402, 409, 410, 422, 423, 428, 429, 430, 433, 437, 443, 444, 455, 457, 459, 463, 464, 466, 470, 471, 472, 484
Jackson, Prof. Dugald C.....	340, 356, 458
Jamieson, Prof. Andrew.....	139, 158, 159, 163, 219, 220, 232
Johnston, W. J.....	338
Keith, Dr. N. S.....	408, 466
Kennelly, A. E.....	160, 182, 183, 195, 196, 251, 252, 486
Kimball, A. L.....	111
Langley, Prof.....	181
Law, M. D.....	368
Lemp, Hermann.....	141, 468
Lindeck, Dr. Stephan.....	165, 181, 182
Lockwood, T. D.....	136, 159, 370, 376, 484
Longden, A. C.....	230
Low, George P.....	338, 340, 400
Lummer, Dr.....	484
MacFarlane, Prof. A.....	24, 31, 74, 111
Marks, Louis B.....	387, 400, 401
Martin, T. C.....	xxi, 475
Mascart, Prof. E.....	14, 17, 484, 486
McDonald, George W.....	401
Mendenhall, Prof. T. C.....	10, 14, 15, 16, 17, 19, 484
Nichols, Prof. E. L.....	18, 399, 485
Palaz, Dr. A.....	157
Patterson, Prof. G. W.....	202, 208
Perrine, Dr. F. A. C.....	338, 341, 354, 355
Pollak, Dr. Chas.....	438
Pope, Ralph W.....	338, 485
Preece, W. H.....	4, 13, 15, 16, 17, 18, 19, 20, 118, 119, 196, 189, 141, 196, 337, 484, 485, 486
Reber, Lieut.....	118, 215, 278, 337
Reed, J. O.....	231
Roberts, Prof. E. P.....	338, 400
Rowland, Prof. H. A.....	16, 17, 18, 19, 22, 23, 31, 335, 455, 484
Sahulka, Dr. J.....	15, 105, 157, 379
Schulze-Berge, Dr. F.....	342, 353, 355
Scott, C. F.....	417
Siemens, Alexander.....	16, 18, 161, 163
Steinmetz, Chas. P.....	33, 75, 436, 464
Stillwell, A. B.....	428
Swinburne.....	267
Tesla, Nicola.....	475
Thomas, Prof. B. F.....	197, 198, 202, 203, 273

Thompson, Prof. S. P.....	16, 18, 118, 143, 159, 162, 163, 164, 181, 266, 267, 400, 409, 430, 484
Thomson, Prof. E.....	4, 6, 9, 10, 13
Violle, M. J.....	258, 259
Webster, Prof. A. G.....	210, 211, 212, 265
Wegan.....	140
Weston, Edward.....	176, 183
Wetzler, Joseph.....	340
Wilkinson, Prof. Henry D.....	161
Wolcott, Townsend.....	338
Wyman.....	140

TITLES OF PAPERS AND TOPICS DISCUSSED.

Address, Prof. Ayrton's.....	6
Address, Dr. E. Gray's.....	1, 13
Address, Dr. H. von Helmholtz's.....	11
Address, Prof. E. Thomson's.....	4, 12
Address, W. H. Preece's.....	13
Adjournment of Congress.....	486
Adjournment of Section B.....	387
Adjournment of Section C.....	474
Air Pump, Rotary Mercurial.....	342
Alternate Current Problems, The Extended Use of the Name Resistance in	117
Alternating Arc Lights, Periodic Variation of Candle Power in.....	273
Alternating Circuits, on the Source and Effects of.....	335
Alternating Current Arc, New Researches in.....	279
Alternating Currents, On the Analytical Treatment of.....	24
Alternating into Continuous Currents, a Novel Method of Transforming...	438
Ampere, Ohm, Volt, Committee on.....	17
Analytical Treatment of Alternating Currents.....	24
A Pair of Electrostatic Voltmeters.....	205
Arc and Its Employment as a Photometric Standard on the Continuous Current.....	315
Arc Lamp with Constant Watts, On the Maximum Efficiency of.....	270
Arc, Light and Heat of the Electric.....	259
Arc Light, A New Incandescent.....	387
Arc Light, Periodic Variation of Candle Power in the Alternating.....	273
Arc, New Researches in Alternating.....	279
Arc With Current, Size of Carbons and Distances Apart, Variation of the Potential Difference of the Electric.....	258
Banquet, International Electrical Congress.....	483
Candle Power in Alternating Arc Lights, Periodic Variation of.....	273
Capacity of Insulated Wires with Temperature, Note on the Variation of..	473
Chamber of Delegates, Proceedings of.....	15
Chamber of Delegates, Final and Official Recommendation of.....	20

Chronographic Purposes, On a Method of Governing an Electric Motor for	212
Committee on Credentials and Permanent Organization	15
Committee on Ohm, Ampere and Volt	17
Committee on Standard of Light.	18
Complex Quantities and Their Use in Electrical Engineering.	33
Congress, Opening of.	1
Continuous Current, A Novel Method of Transforming Alternating Into.	438
Continuous Current Arc and Its Employment as a Photometric Standard, On the.	315
Credentials and Permanent Organization, Committee on	15
Current, Electromotive Force and Resistance, Work Done Upon.	16
Current, Flow in Two Mutually Related Circuits, Containing Capacity, General Discussion of.	76
Delegates, Proceedings of Chamber of.	15
Direct Current Dynamos of Very High Potential	408
Distribution, Underground Wires for Electric Lighting and Power.	356
Dynamos of Very High Potential, Direct Current	408
Effects of Harmonics in Alternating Circuits, On the Source and.	335
Efficiency of Arc Lamps with Constant Watts, On the Maximum	270
Electrical Engineering, Complex Quantities and Their Use in.	33
Electrical Engineering Laboratories, London.	220
Electrical Resistance of a Sample of Copper, Some Measurements of the Temperature Variation in	183
Electrical Resistance, Materials for Wire Standards of	165
Electric Arc, Light and Heat of the.	259
Electric Light and Power Distribution, Underground Wires for.	356
Electric Motor for Chronographic Purposes, On a Method of Governing an.	212
Electric Oscillation, Tesla Mechanical and.	475
Electromagnetic Vibrations, Signalling Through Space by Means of.	119
Electrostatic Voltmeters, A Pair of	205
Electrostatic Voltmeters, Various Uses of the	379
E. M. F., Resistance and Current, Work Done Upon	16
Energy of Polyphase Currents, Measurement of the.	112
Engineering Laboratories, London Electrical.	220
English.	15
Experimentally Determined, Transformer Diagrams.	234
Exhibit of Tesla Polyphase System at the World's Fair.	417
Explanation of the Ferranti Phenomenon	105
Ferranti Phenomenon, Explanation of the.	105
Final and Official Recommendation of the Chamber of Delegates.	20
Final General Meeting of the International Electrical Congress	435
General Discussion of the Current Flow in Two Mutually Related Circuits, Containing Capacity	76
General Meeting of the International Electrical Congress, Final	435
Governing an Electric Motor for Chronographic Purposes, On a Method for	212
Harmonics in Alternating Circuits, On the Source and Effects of.	335
Heat and Light of the Electric Arc.	259

Henry, the Practical Unit of Self-induction.....	17
High Potential, Direct Current Dynamos of Very.....	408
Incandescent Arc Light, New.....	387
Induction, The Practical Unit of.....	17
Instrument for the Measurement of Magnetic Reluctance, On an Improved Form of.....	252
Insulated Wires with Temperature, Note on the Variation of Capacity of ..	473
Iron for Transformers	216
Laboratories, London Electrical Engineering.....	220
Language of Chamber of Delegates, Official.....	15
Light and Heat of the Electric Arc	259
Light, Committee on Standard of.....	18
Lighting and Power Distribution, Underground Wires for.....	356
Light, New Incandescent Arc.....	387
Light, On the Swinburne-Thompson Unit of.....	267
London Electric Engineering Laboratories	220
Magnetic Reluctance, On an Improved Form of Instrument for the Measure- ment of.....	252
Magnetic Units.....	18
Materials for Wire Standards of Electrical Resistance... ..	165
Maximum Efficiency of Arc Lamp with Constant Watts, On the.....	270
Mercurial Air Pumps, Rotary... ..	342
Measurement of the Energy of Polyphase Currents.....	112
Measurement of the Magnetic Reluctance, On an Improved Form of Instru- ment for the.....	252
Measurements, Note on Photometric.....	198
Measurement of the Temperature Variation in the Electric Resistance of a Sample of Copper.....	183
Method of Transforming Alternating into Continuous Currents, A Novel..	488
Motor for Chronographic Purposes, On a Method of Governing an Electric.	212
Motors and Power Transmission, Multiphase	411
Multiphase Motors and Power Transmission.....	411
Mutually Related Circuits, Containing Capacity, General Discussion of Cur- rent Flow in.....	76
New Incandescent Arc Light.....	387
New Researches on the Alternating Current Arc.....	279
Nomenclature and Notation.....	16
Notation and Nomenclature.....	16
Note on Photometric Measurement.....	198
Note on the Variation of Capacity of Insulated Wires with Temperature... ..	473
Novel Method of Transforming Alternating into Continuous Current.....	488
Ocean Telephony	143
Official and Final Recommendation of the Chamber of Delegates.....	20
Official Language of Chamber of Delegates.....	15
Ohm, Ampere, Volt, Committee on.....	17
Opening of Congress.....	1
Organization, Committee on Permanent.....	6, 10
Oscillators, Mechanical and Electrical.....	475

Periodic Variation of Candle Power in Alternating Arc Lights.....	273
Permanent Organization, Committee on.....	6, 10
Permanent Secretary.....	10
Photometric Measurement, Note on.....	198
Photometric Standard, On the Continuous Arc and Its Employment as a... ..	315
Polyphase Currents, Measurement of the Energy of.....	112
Polyphase System at the World's Fair, Exhibit of Tesla... ..	417
Power Distribution, Underground Wires for Electric Light.....	356
Power Transmission, Discussion.....	423, 444
Power Transmission, Multiphase Motors and.....	411
Proceedings of Chamber of Delegates.....	15
Proceedings of Section A.....	22
Proceedings of Section B.....	118
Proceedings of Section C.....	388
Pumps, Rotary Mercurial Air.....	343
Reluctance, On an Improved Form of Instrument for the Measurement of	
Magnetic.....	252
Researches on the Alternating Current Arc, New.....	279
Resistance, Current, Electromotive Force, Work Done Upon.....	16
Resistance, Materials for Wire Standards of Electrical.....	165
Resistance of a Sample of Copper, Some Measurements of the Temperature	
Variation in the Electrical.....	183
Rotary Mercurial Air Pumps.....	343
Secretary, Permanent.....	10
Secretary, Temporary.....	6
Section A, Proceedings of.....	22
Section B, Adjournment of.....	387
Section B, Proceedings of.....	118
Section C, Adjournment of.....	474
Section C, Proceedings of.....	388
Signalling Through Space by Means of Electromagnetic Vibrations.....	119
Some Measurements of the Temperature Variation in the Electrical Resist-	
ance of a Sample of Copper.....	183
Source and Effects of Harmonics in Alternating Circuits.....	335
Standard of Light, Committee on.....	18
Standard, On the Continuous Current Arc and Its Employment as a Photo-	
metric.....	315
Telephony, Ocean.....	143
Temperature Variation in the Electrical Resistance of a Sample of Copper,	
Some Measurements of.....	183
Temporary Secretary.....	6
Tesla, Mechanical and Electrical Oscillators.....	475
Tesla Polyphase System at the World's Fair, Exhibit of.....	417
Transformers, Iron for.....	216
Transformer Diagrams Experimentally Determined.....	234
Transforming Alternating into Continuous Currents, A Novel Method of... ..	438
Transmission of Power, Discussion.....	423, 444
Transmission, Multiphase Motors and Power.....	411

INDEX.

xix

Underground Wires for Electric Lighting and Power Distribution.....	356
Unit of Light, On the Swinburne-Thompson	267
Variation of Candle Power in Alternating Arc Lights, Periodic.....	273
Variation of Capacity of Insulated Wires with Temperature, Note on the..	478
Variation of Potential Difference of the Electric Arc with Current, Size of of Carbons and Distance Apart	258
Various Uses of the Electrostatic Voltmeter	379
Voltmeters, A Pair of Electrostatic.....	205
Voltmeters, Various Uses of the Electrostatic	379
Volt, Ohm, Ampere, Committee on....	17
Wires for Electric Lighting and Power Distribution, Underground.....	356
Wire Standard of Electrical Resistance, Materials for... ..	165

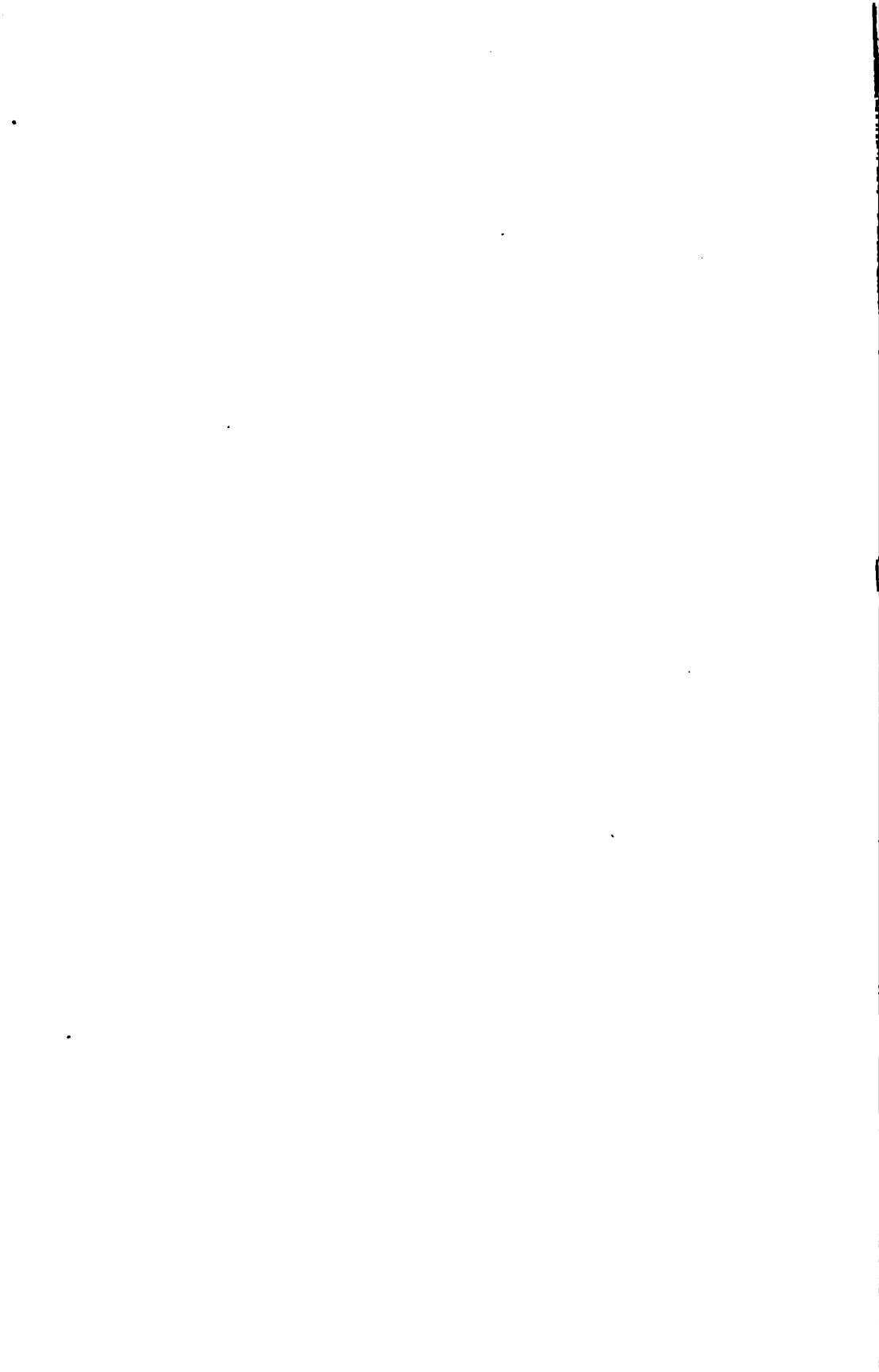

HISTORY OF THE CONGRESS.

BY T. C. MARTIN.

THE predecessor of the Chicago International Electrical Congress was that held at Frankfurt, Germany, in 1891, at which time the delegates of the American Institute of Electrical Engineers extended, in the name of that body, an invitation to European electricians to participate in America. During 1891, a "Congress Auxiliary" was formed, with the support of the Columbian Corporation and under the sanction and approval of the Government of the United States, in connection with the World's Columbian Exposition at Chicago, and the organization of a World's Electrical Congress was undertaken by a special Chicago Committee, of which Dr. Elisha Gray was appointed chairman. At this time the Institute was invited to associate itself with other engineering societies in organizing an Engineering Congress, of which the electrical part would be entrusted to it. This proposition was declined, however, and by vote of Council in December, 1891, the Institute pledged itself to full and hearty cooperation with Dr. Gray and the Chicago Committee, of which Mr. Robert C. Clowry had been appointed vice-chairman and Prof. Henry S. Carhart, secretary.

Early in 1892, Dr. Gray selected the Advisory Council for the Electrical Congress, inviting the active cooperation and assistance of each member.

The work of preliminary organization was pursued throughout 1892, and on January 17, 1893, a meeting of the Advisory Council was convened in New York City by Dr. Gray, when steps were taken to determine the nature, work and membership of the Congress, as well as the time of its assembling. At this

meeting, preliminary reports of English and American committees, touching these points, were submitted.

It was thereupon resolved that the Electrical Congress of 1893, should consist of two Chambers, of which the Legislative Chamber should decide on units, names of units, and standards, and should consist solely of delegates named by their respective Governments.

The following apportionment of delegates was made by a Committee whose report was adopted by the meeting. Great Britain 5, France 5, Germany 5, Austro-Hungary 5, United States 5, Belgium 3, Italy 3, Switzerland 3, Holland 2, Denmark 2, Norway and Sweden 2, Russia 2, Spain 2, Portugal 1, British North America 1, Australian Colonies 1, India 1, Japan 1, China 1, Mexico 1, Brazil 1, Chili 1, Peru 1, Argentine Republic 1, making a total of 55 official delegates.

It was resolved that a Committee on Invitations should be appointed by the Chairman, to consist of five members, who should select and recommend to the Chairman the names of electricians, electrical engineers and others as members of the Electrical Congress. Said Committee to cooperate with the foreign Committees.

It was further resolved that in addition to invitations to deliberating and voting members of the Congress, a general intimation should be extended through the journals or otherwise that the meetings would be open to the public, for attending the proceedings, but not for taking part therein.

It was resolved that a Committee on Programme and Papers should be appointed by the Chairman, to consist of eight members, whose duty it should be to invite, receive and consider papers and other documents relating to the work to be done by the Congress. And it was further resolved that it should be the duty of this Committee to formulate a Programme for the Congress.

It was resolved that the reports of the English and American Sub-Committees which had been received at the meeting should be referred to the Committee on Programme and Papers, and that the Committee confer with the English Committee as fully as possible and with such other foreign Committees as might be formed.

It was resolved that the Electrical Congress of 1893 should last one week, beginning on August 21st; that a Committee of

three should be appointed by the Chairman as a Finance Committee that an Executive Committee of five should be appointed by the Chairman, said committee to have full power to act for the Advisory Council; and that the question of charging a fee for membership of the Congress, and fixing the amount of such fee should be referred to the Executive Committee.

Within a few days, Dr. Gray selected the following committees, which immediately took up their respective duties: Executive Committee, Finance Committee, Programme and Papers Committee, Invitations Committee. Of these committees, Dr. Gray was a member *ex-officio*.

The various governments were requested to name and appoint their delegates, as required by the foregoing resolution; while about 1,000 invitations were issued to membership in the general body, besides which the following technical societies abroad were courteously notified that their members would be welcome and would, on application, be furnished with tickets of admission:— Société des Sciences, Christiania, Norway; National Electric Light Association, Tokio, Japan; Electrical Society of Japan, Tokio, Japan; Société Electrotechnique de St. Petersburg, Russia; Schweizerischer Elektrotechnischer Verein, Switzerland; Société Electrotechnique de Paris; Elektrotechnischer Verein, Berlin, Germany; Elektrotechnischer Verein, Vienna, Austria; Institution of Electrical Engineers, London, England; Société Internationale des Electriciens, Paris, France; Société Belge des Electriciens, Brussels, Belgium, Società Italiana di Elettricità, Milan, Italy.

The U. S. Government also requested and received invitations for officers in certain of the services interested in electricity, and similar requests came from England.

The Congress was opened in Columbus Hall at the Art Institute, Chicago, on August 21, when upwards of 500 persons were in attendance. The proceedings were brought to a close by a banquet on August 24, at the Grand Pacific Hotel, and by a lecture by Mr. Nikola Tesla, on August 25, in a hall at the Agricultural Building, on the World's Fair Grounds.

The report of the Congress transactions constitutes this volume.

Saturday, August 26, was largely given up to joint excursions and pleasure trips by the Congress, to which many invitations and courtesies were extended. The members assembled first at the exhibit of the American Bell Telephone Company in Elec-

tricity Building at the Fair, in the early afternoon, and witnessed tests of long-distance lines, exchange service and experiments with the radiophone. The Western Electric Co. then took the party in hand, and the president, Mr. E. M. Barton, assisted by Mr. W. R. Patterson, took the visitors through their exhibit, including the Scenic Theatre.

The exhibit of Gray's perfected telautograph was next visited.

At 5 o'clock a reception was given by Mr. W. H. Preece, president of the English Institution of Electrical Engineers, at Victoria House, the headquarters of the British Commission.

At 7 p. m. the exhibit of the General Electric Co., throughout its various departments, was inspected under the guidance of Lieut. Spencer and his assistants. Next came a visit to the exhibit of the Westinghouse Electric and Manufacturing Co. Through the courtesy of the Department of Electricity, a collation was then served to members of the Congress, at 10 p. m., at Electricity Building. The evening was also interspersed with other engagements and courtesies. At 8.30 the members of the Chamber of Delegates were invited to ride on the huge Ferris wheel; while the Libbey Glass Co. and the Electric Scenic Theatre honored the Congress badges throughout the day. There were various private festivities during the week in Chicago, in connection with the Congress. Among these was the reception given on Friday night to Prof. von Helmholtz at the residence of Mr. O. W. Meysenberg, President of the Congress.

OPENING OF THE CONGRESS.

The Congress was called to order at 3 P. M., Monday, August 21st, 1893, at the Art Institute, by Dr. Elisha Gray, of Chicago, the Chairman of the Electrical Congress Committee of the World's Columbian Exposition, who made the following address:

Gentlemen of the International Electrical Congress:

I esteem it an honor of the highest distinction to be permitted to call this International Electrical Congress to order; coming as you do from all parts of the world, and distinguished as many of you are, for your contributions to the world's progress through the medium of science—theoretical and applied.

The time and the place are both most opportune. Men who represent the best thought, and the best work of the world are here. The scientists who seek to unlock the secrets of nature, and open up to man new fields for research, and further add to the sum of useful knowledge, are here. The achievements of the world's thought, the world's skill, the world's genius, are all about us; worked out in machines, in fabrics, in painting, sculpture and architecture.

The whole atmosphere is surcharged with the activities of all nations—material and intellectual. We cannot help but draw inspiration from such surroundings and have our minds so attuned for the work before us, that the very best results shall come from our deliberations. We have here to-day men who represent almost every phase of electrical work; men who come from the school, the college, the university, the laboratory of the scientist, and from the commercial walks of life. And then we have with us that other much abused but necessary citizen, the inventor; the man who is, in some degree, a combination of all the rest, and is the product of daylight toil and midnight oil. It is fitting that all these varied capacities should come together

in one great convention like this. The smallest of us will learn much that we could not in any other way, and the greatest will go away broader if not wiser men.

What is true of nations is, in a sense, true of individuals. A nation cannot be great and attain to a high degree of civilization, unless her people are surrounded by a large variety and high quality of material—moral and intellectual forces. These forces are so related, that in the grand march of progress, they cannot be separated without lowering the grade of the final result. The individual cannot be great in his vocation or profession if he always lives and works within narrow lines. Every science is more or less related to every other science; so that to know any one thoroughly, it is necessary to know something of all. In other words, to be a good specialist one must begin by being a good generalist. We meet together to-day within the lines of one great and growing profession, that of electricians, and one that is growing daily in importance. The science of electricity has so many ramifications that it is impossible for any one man, unassisted, to compass the whole in a life-time. We find ourselves, all workers, in one great but divided field. Some of us are devoted to pure science, some to science and practice, and some to pure practice—while all are necessary factors composing one complete whole. The pure scientist cannot carry on his work without the aid of the man who applies scientific discovery to useful machines, and instruments for research; and the great world cannot be benefited by the discoveries of scientists, and the applications of inventors, without the man of practice, who is the medium between the inventor and the user. Let us then expect that the results of this Congress will be far-reaching, that it will impress itself upon the lives and work of many of its members, and that all of us will gather fresh inspiration by this commingling of diverse capacities and the fellowship of kindred spirits.

The rapid strides that have been made in electrical science and electrical invention in the last twenty-five years, have marked a new era in our civilization, and this age may well be denominated the Electric Age. Who knows what the next quarter of a century will bring to us, through the medium of electricity? To some people it seems as if the limit were nearly reached; but who knows? A certain professor of physics, who lived and taught, some fifty years ago, thought even at that time that the

limit had been reached—if we may judge by a lecture given on a certain occasion to his class. He had been explaining the experiments of Franklin, who as the Fourth-of-July orator puts it, “Caught the forked lightning from the clouds, tamed it and made it subservient to the will of man.” At the conclusion of his lecture on electricity, which consisted of a description of the celebrated kite experiment, he said: “Young men, you were born *too late* to witness the growth and full development of this great science—electricity.” If the good professor has been allowed to peer from behind the veil, and to watch the progress of the science since his demise, he must be possessed with a growing conviction that he made a mistake when he said “too late,” and that he should have said “*too early*.”

The grand results that have thus far been attained, were not accomplished by any one nation or individual. We, as Americans, are proud of our native land—the land of Franklin, Morse and Henry, but we are also proud of our father-land, and we believe that the father-land is just a little proud of us—although we neither of us say this too often, or too loud. The father-land of America is all the civilized world, outside of its own borders. We are proud of an ancestry, from which spring such men as Faraday and Lord Kelvin, such men as Ampère and De La Rive; such men as Galvani and Volta; and last but not least, we are proud of an ancestry that produces such men as our honored guest—Dr. von Helmholtz.

To you gentlemen who come from the cities and hamlets within the borders of our own land, I do not need to extend a welcome to America, for you are a part of the sixty-five millions of people who live under the protection of this grand old flag of ours; but I do extend to you a hearty welcome to Chicago, the commercial metropolis of America. To you who come from foreign shores, not only *Chicago*, but *America* extends a royal welcome. We welcome you on behalf and in the name of the electricians of America; and finally we welcome you in the name of our own loved science which knows no geographical boundaries but includes the whole brotherhood of man. For myself, as Chairman of the Committee of Organization, I wish to extend thanks to my fellow-workers who compose the various sub-committees at home and abroad, including both those appointed by the Advisory Council and the American Institute of Electrical Engineers, for the invaluable aid they have given me without which this Congress could not have been organized.

My work as head of the organization committee ends here, and I now surrender this Congress into your hands, feeling assured in advance that the work will be well done; for bad work coming from such an able and distinguished body of men would be an incongruity that is unthinkable.

Upon the conclusion of Dr. Gray's address, he said: Now, gentlemen of the International Electrical Congress, the first thing in order will be the election of a temporary chairman.

MR. WILLIAM H. PREECE, of London, England:—Mr. Chairman and gentlemen, I have been asked, as the first duty connected with this Congress, to propose to you briefly the election of a temporary chairman, and I propose for that function a gentleman of whom we are very proud in England, for he was born there, a gentleman of whom you are very proud in America, for he lives here and has made his reputation here. I propose for a temporary chairman, and I hope you will carry it by acclamation, the name of Prof. Elihu Thomson.

Mr. Thomson was unanimously elected temporary chairman. Coming forward to assume the duties of the position, he was received with hearty applause. In accepting the nomination he addressed the Congress as follows:

I thank the Congress very much for calling me to the Chair at this time, even though it be but the temporary chairmanship. I certainly would be fully repaid at any time in any gathering of this kind in doing anything I could to favor its plans and to carry on its pursuits.

We are gathered here as representatives of the departments of that grand science which, though not in its infancy—as we sometimes see the newspapers state—has yet the power of youth and the power of an unceasing youth we believe in the time to come. It is that science which when we visit the grand collection of man's industrial achievements down here at Jackson Park, we are proud of; it is that science which has made such a collection and such an exhibition even possible. If an attempt had been made fifteen years ago to produce the results which are there exhibited, where should we have been? Everywhere that you go you will find evidences of the work of electricity—all accomplished within this brief period of years. Yet many of the principles of them were known long before, and we bow to the army of workers who have brought about this grand success. Many of the prominent ones have passed away.

In relation to a remark made by Dr. Gray, that there was not very much more to learn, that somebody had been born too late, I called to mind an expression I found in an old book in regard to electricity. I think it was a book on physics, printed a hundred years ago. The statement in the book was that the advances had been so rapid and so numerous that it really did not seem that there was any direction in which discoveries were likely to be made in electricity. All that the book dealt with was the old frictional machine, the Leyden jar and a number of luminous experiments on vacuum tubes, etc. Shortly after the publication of that book there came along the whole of the discoveries in voltaic electricity, opening up that very wide field which has gone on expanding up to the present time, and which will go on expanding, following the development of that field and opening up what we call the dynamo-electric field, which is really an extension or expansion of the voltaic theory. But to-day we recognize no such distinctions. The electricity of to-day is one and the same thing, whether you see the current used by thousands of amperes to weld masses together, or whether you see the lightning striking from a thunder cloud to the earth. In both you see the same thing, only in one instance you have no pressure and enormous volume, just as a huge river floats on without having any perceptible head or anything to force it along; and in the other case you have enormous pressure and a very small amount of volume.

It is the glory of all science that it works not only to discipline and enhance the intellectual advancement of man, but it also confers practical benefit, and it is the peculiar glory of electrical science that, study it, delve in it merely for mental discipline, and you will find it one of the best exercises imaginable. If you work in it for practical uses you will find that it has the possibility of ramification into innumerable fields. It is almost a universal science.

Can you wonder then that we are enthusiastic? That we are proud to work in a field of this kind? It is the modern field; the field which will in the future give us the power to do things which to-day we cannot conceive possible. Beginning with small things, beginning sometimes with merely theoretical developments, developments of very little practical interest, we find as time goes by those very things becoming of practical use. And so it is with science in all its departments; no part of it can be

considered as useless from a practical standpoint.

Let us then join together to make this Congress a memorable occasion, a celebration, as it were, of the past fifteen or twenty years, and the years that have gone before that period in the grand developments which have taken place in electrical science. The best way to do that is to get together and exchange ideas and discuss points of difference of opinion, or of unanimity of opinion, if you please, and endeavor to spread information abroad to extend the shore of our knowledge.

We have with us to help out in this grand and good work, men of distinction from every clime. We have some with us who have earned the highest distinctions, and I am glad to say that they will be of the greatest assistance to us Americans who attend largely to practical work, in keeping us out of altogether practical ruts.

The order of business for to-day will be, first, the election of a temporary secretary.

One motion of Prof. Cross, Prof. F. B. Crocker, of New York, was unanimously elected temporary Secretary of the Congress.

THE CHAIRMAN: The next business is the appointment of a Committee on Permanent Organization.

In accordance with the suggestion of the Chairman, the following gentleman were unanimously appointed a committee on permanent organization:

Dr. T. C. Mendenhall, Washington, D. C. ;
 Prof. Benjamin F. Thomas, Columbus, Ohio ;
 Dr. Louis Duncan, Baltimore, Md. ;
 Dr. S. P. Thompson, England ;
 Prof. E. Hospitalier, France ;
 Dr. A. Lindeck, Germany ;
 Dr. A. Pallaz, Switzerland ;

THE CHAIRMAN: I am at liberty to call upon a gentleman to say a few words to you in connection with the electrical part of the World's Fair as seen from a foreigner's standpoint. The gentleman whom I shall call upon is undoubtedly known to us all by reputation. He is a man who has combined in himself not only pure science but its application; a gentleman who has been a worker in the field for many years. I call upon Prof. William E. Ayrton of London, England.

Prof. Ayrton was received with warm applause as he came forward to respond. He addressed the Congress as follows:

There is one thing, ladies and gentlemen, which I certainly am not, which Prof. Thomson has told you I was; namely, a

foreigner; for no Englishman can possibly be a foreigner in America.

In asking me to say a few words about a stranger's—not a foreigner's—impression of the electrical display at the Exposition, I imagine that the Committee of the Congress considered it was desirable to precede the more solid meal of mathematical technicalities which we electricians are compelled to feed upon, by something a little light; and therefore, it has fallen upon me to supply the radishes and the caviare which form the first course of the intellectual banquet which the committee have provided for you.

In order that one may judge of this country, it is most important to free oneself from the conservative prejudices so common in an inhabitant of the Old World. I have therefore endeavored as far as lay in my power, to look upon things here with an open mind. If by chance any of my conclusions may seem a little pointed, I ask you to remember that caviare is made intentionally a little piquant to stimulate your appetite for the more solid dishes that will follow.

Chicago is a long way from the sea, and therefore a vast territory has to be crossed before one can get here. The stranger's impression of the electrical display of America begins to be formed long before he arrives at the White City. The glow-lamps which he sees lighting even your scattered houses, the arc lamps which he sees burning in your country lanes, the electrical tramways readily carrying the working population of your cities into healthy suburbs in the evening when their day's work is over—all these fill the stranger with admiration, and he feels pleased to know that you have no Board of Trade to control your affairs. However, when in a city like Baltimore he finds that the roads which are destined to become electric, have been converted into Alpine mountain passes by the construction of electric tramways, when he sees jumbled up on the same posts telephone, telegraph and high-pressure electric-light wires, sometimes with insulation a little defective, he becomes reconciled again to the dominion of Whitehall and he takes comfort to himself in the thought that high-pressure transformers are not stuck like flies on the house-walls in his own country. When he learns that the load on the down-town electric mains in New York is at a maximum at 2 in the afternoon, his mouth waters at such a paying load-line, and he would rush to take a share in such a prosperous undertaking

except for the recollection that one or a ten per cent. dividend come to much the same thing when there is no currency whatever to pay the dividend declared. In Pittsburg, Cleveland, Lynn and Schenectady the stranger is much astonished at the courtesy with which he is shown every detail in a factory, as well as the magnitude of the undertakings. His expectations are roused to such a pitch that he expects when he gets here in Chicago to find an electrical display which will cast all previous electrical exhibitions into the shade.

Well—take this stranger into the Electricity Building blindfold, so that his judgment may not be warped by the glories of the outside surroundings and leave him there for awhile. If he be candid and if he can muster up courage to say a word which might cause pain to those whose kindness has made them dear to him, he will say that he is a little disappointed. He is disappointed that the world has not better answered the invitation to show in Electricity Building what it could do. If he is an Englishman, he is not only disappointed but rather ashamed of his country. Even looking at the Electricity Building from a purely American standpoint, if you will allow me to say so, I do not think the exhibits inside quite do this country justice. We have all heard of the arrangements that are being made to utilize 300,000 horse power at Niagara, the greatest engineering feat, probably, that the world has ever seen. But in the exhibition I think I am right in saying that not a model or a plan can one find of the work that this country is doing, and which will when accomplished redound to its praise. It might seem a small thing, compared with that, to transmit a little over a hundred horse power 109 miles with a commercial efficiency of 75 per cent; but at Frankfort the stranger really did see that done; and although that was but a small thing compared with what America is doing at Niagara, one would like to have seen something on the spot. In other words the stranger feels that the real electrical display of America is not in Electricity Building, but in every street where there are trolley wires, in every town and village where there are electric lamps; and where is the town in this country where there are none?

But if the stranger be thoughtful, he is not disappointed. At Frankfort it was what was inside the Electricity Building that dazzled his mind. At Jackson Park it is what is outside the Electricity Building that rivets his attention. One feared that the

bustle and hurry of this country would not allow time for the appearance in the programme of its development, the cultivation of those charms that Americans come to Europe to witness; but when I saw your exhibition, when from the top of the Manufacturers' Building I looked down at night on that Court of Honor, on that tracery of electric lamps, more beautiful in its realization than could have been even the dream of the writer of the Arabian Nights, then I felt sure that in that great living hospitable heart which throbs in the breasts of the all-practical, go-ahead people of this country, there must be some nook where lurks the belief, that powerful as is machinery, all-powerful as is electricity, the song, the poem, the echo of the statue that lives when the bones of its creator have crumbled into dust, are even more powerful still in forming the history of humanity.

But your exhibition makes me hope that the love of art and beauty for their own sakes, which we have hitherto regarded as the heritage of poor and oppressed races like those of Italy, Hungary and Russia, will become the heritage of this great free nation.

There is one exhibit in Electricity Building which struck me very forcibly—an exhibit which does not appear in the catalogue—and that is the young American electrician. Deeply interested as I am in the teaching of the application of science to industry, nothing could have pleased me more than to see the value that you electrical engineers of this country attach to the bright lad who has had good college training, and while great feats have been achieved and are being achieved by veterans like Edison, Gray, Elihu Thomson, Westinghouse and others, you trust the development of your electrical enterprises in the hands of those whose skill merits your confidence, whose youth does not cause you distrust.

As one grows older, age, like electric self-induction, wipes out the minor ripples in the current of one's past life, but certain prominences though rounded with time, are never obliterated. In the current of my life there will ever be one epoch towering far above all others—the epoch labeled "Chicago, 1893."

THE CHAIRMAN:—I am sure that I am at liberty on the part of the Congress to tender the thanks of this body to Prof. Ayrton for the charming address he has just delivered. Perhaps there is one remark that I should make which occurred to me while he was speaking in regard to the plans and arrangements for

Niagara. I do not know that they are completed, and I believe Prof. Forbes has them in charge. Prof. Ayrton reminds me that he actually did speak of Englishmen not coming up to the mark. So he wishes it to be inferred that that remark is borne out in this instance.

Prof. Mendenhall, from the Committee on Permanent Organization reported the following officers, who were elected by a unanimous vote:

Honorary President, His Excellency Dr. H. von Helmholtz, of Berlin, Germany.

Permanent Chairman, Dr. Elisha Gray, of Chicago.

Vice-Presidents: Edward Weston, United States; W. H. Preece, *F. R. S.*, Great Britain; Prof. E. Mascart, France; Dr. Voit, Germany; Prof. J. Sahulka, Austria; Prof. Galileo Ferraris, Italy; Prof. H. Weber, Switzerland.

Permanent Secretary, Prof. F. B. Crocker, New York.

The list of vice-presidents as above given is incomplete, because of the non-arrival of representatives from other countries who have signified their intention of being present. Upon their arrival the list of vice-presidents will be completed.

Chairman Thomson escorted to the chair, Dr. von Helmholtz, the Honorary President-elect, who was received with cheers and a rising salute by the Congress. Chairman Thomson introduced the eminent scientist as follows:

It now becomes my most pleasant duty to present to you the Honorary President selected by the Congress, a man whose name and fame are really known wherever science is taught, a man whose varied achievements in all departments have made him the type of the man of general science; a man whose work has gone to make many of the scientists what they are to-day, and of whom it would be difficult to say whether in optics, in sound, in electricity, in the laws of motion and the conservation of energy he had done the most work. An optical congress might claim him; a congress of sound and music might claim him, and a congress of electricians has claimed him and we have him.

It is to his fundamental studies on the laws of fluid motion, on the laws of conservation of energy that we electricians must look. These studies, carried on long ago, laid the foundation for the work of others who came after him. We find much of the work of even the great master, Maxwell, depending on the labors of the gentleman whom I am to present to you. I now have the honor to present to you as your Honorary President, His Excellency, Dr. von Helmholtz.

The Congress again rose and saluted their distinguished Hon-

orary President, who, when the cheering subsided, addressed the body as follows:

Ladies and gentlemen, I must say that I am almost overpowered by the excessive honor which you have given me, for I am not quite sure that I possess the merits necessary to fill the distinguished position to which you have called me. I have been occupied with electricity, that is true. It may be that in your selection here you have given to old age the privilege of being honored more than usual, even if the merits of the individual are doubtful.

I think I am the most aged of the electricians who are present here. The beginning of my career was at a time when the phenomena of electricity were apparent only by the most delicate experiments in the laboratory. Where we to-day move great machines of the mightiest power, in that old time when I began to study electricity we could only move little magnetic needles suspended on the finest silken thread that we could obtain. We balanced two such needles on the opposite poles in order to get any token of electrical current, or even the most delicate index of electrical current, such as was obtained by Volta from the frog. He could do nothing but make an oscillation or contraction. He could not move the slightest apparatus, but he saw that there were feeble currents. At that time we had no constant electromotive force. We were obliged to work with simple battery elements of copper and zinc without sulphate of copper and elements which altered with every movement; which had in the first instance a great electromotive force and then went down, down, down, so that after some minutes there was scarcely any force at all, or only traces of the former force. Now all is changed. In the beginning of my career, we knew nothing of the great discoveries of Faraday regarding inductive currents, which have developed now into currents that can drive the mightiest machines.

The present generation—if I may include myself in the present generation—have seen a greater development of science of every kind, and principally of electric science, than any generation before us. The history of the world and the history of science has grown very rapidly during our life-time. It is a great pleasure for us old men to see now what electricity has reached in its new stages and to admire the newest developments which are collected on this festival occasion here in your great Exhibition.

Permit me to thank you for the great honor you have conferred upon me.

CHAIRMAN THOMSON:—I am sure that the Congress will join me most heartily in the wish that Dr. von Helmholtz may, for many years to come, be included in this generation; that he may live to see the grander accomplishments which are to be achieved, without doubt, in our favorite science.

I have no need to introduce the next gentleman, Dr. Gray, to the Chicago public. He is perfectly well known in the city here, as the type of the practical inventor and scientific man. He was prominent early in working out systems of transmission of intelligence. I remember personally that when I was a mere boy, I saw an exhibition of his harmonic telegraph, which interested me very much indeed. It came some years before the telephone, and if the telephone had not come, I am certain that the electro-harmonic telegraph of Dr. Gray would have been doing a large amount of work to-day. But Dr. Gray not only invented the harmonic telegraph, but he has also been connected as an early pioneer with the invention of the telephone itself. I remember seeing at that early exhibition of which I spoke, one experiment which gave such promise of talking that it almost sounded as though it did talk. It was an experiment in which Dr. Gray simply held his hands on a little zinc cylinder and the sound came from his fingers or the cylinder—a contact vibration. The sound was given at the other end by a diaphragm, and breaking and making contact very similar to the Reis telephone, but the sounds were so near talking that I thought there was very little to be done to make it talk. Dr. Gray very soon after that, did that thing which would have made such an instrument talk.

Dr. Gray to-day has presented to the world, after a long siege of hard work, the telautograph, which is certainly a marvelous instrument; one which enables us to take up a pen at one station and produce a written record or a drawing—in fact, to produce any system of lines you choose—at a distant station, several instruments being operated at the same time. So that he has been hard at work as an inventor, and as an inventor I can feel the most thorough sympathy with him, for inventors meet with many difficulties and rebuffs, and it is only by trial after trial that they get that perfect thing, or that nearly perfect thing which answers all the commercial purposes of the world.

There is no one more fitted to preside as permanent chairman of this Congress than Dr. Gray. He has had the arrangements for the Congress for a very long time in his hands, and he has worked faithfully and energetically to have the Congress as successful as possible. I can testify to that personally, having been in communication with him.

I now have the pleasure of introducing to the Congress, your permanent chairman, Dr. Elisha Gray.

Chairman-elect Gray was received with hearty applause, in response to which he said: Gentlemen, I am not going to make another speech. I wish simply to heartily thank this Congress for the honor that you have conferred upon me, for it is an honor to act in this capacity, even though it be a subordinate one. It is an honor to act in connection with one who is so distinguished as the gentleman whom you have made your honorary president. I thank you.

In discharging the duties of the position to which you have called me, I ask your forbearance. I ask that you will help me, for it is my intention to preside in the best manner possible, and if any mistakes are made they will be mistakes of the head and not of the heart. I do not intend to take up your time with further remarks, because there are others here who are better qualified to address you than I am and from whom you wish to hear.

I do not need to introduce to this Congress the Vice-President from Great Britain, because wherever the telegraph extends and wherever the science of electricity is known, the name of Mr. William H. Preece, chief engineer of the British Postal Telegraph system is also known. I now call upon him to say a few words to this Congress.

Vice-President Preece was greeted with cheers, upon the subsidence of which he addressed the Congress as follows: Mr. President, ladies and gentlemen, I feel very highly honored in having conferred upon me the position of Vice-President for that very tiny little spot on the ocean that is called "Great Britain." This is not the first time that I have crossed the Atlantic. This is not the first congress that I have attended in America. This is my third visit here, and I have never yet left these shores empty handed. I have always taken something away with me, not surreptitiously, for I think it will be acknowledged that we in England have always handsomely paid for that which we have taken from you.

I have the greatest possible hopes for the success of this Congress. Congresses do an infinity of good. They make us all travel on the same track. We never get shunted into wrong quarters, if we rely upon the ideas that have been inculcated at these congresses. Electricity in all its branches is cosmopolitan. As your Chairman implied, it has no geographical limitations. It knows no nation. It has but one language; and the object of our meeting here is to try to make that language a little more perfect. Its growth and history have been guided by the principle of continuity, and by the principle of evolution, and we are here to show how the modern electrician has planted the ideas of Franklin and Henry and Faraday and Maxwell and others on the history of the present, while we are still working hard to cultivate those seeds planted at our feet by such men as Helmholtz.

But there is one other function that a congress fulfills, and one which I trust we will all do our best to accomplish, and that is to secure amongst ourselves, that alone which makes life pleasant and happy—feelings of friendship and of amity. In my small career I have found that the friendships made abroad at these congresses have been lasting, and I can look around me here and see several of those whom I have met at other congresses, and whom I know that I shall be able to call my friends as long as we live.

One of the earliest lessons that I learned in this lesson-teaching country was this: never prophesy unless you know. Now, I will venture to prophesy this: that when in future ages men shall look back to the annals of history to discover those epoch-marking events that have made history, there will be no assemblage of electricians that will be more indelibly engraved on the marbles of time than this great Electrical Congress of 1893, held in Chicago.

Chairman Gray introduced Vice-President Prof. E. Mascart, of France, who delivered a brief address in his native tongue, thanking the Congress for the honor conferred upon him and prophesying the greatest good to come from the deliberations of the distinguished scientists there assembled.

Dr. Mendenhall presented the programme of exercises to be observed by the Congress during its continuance.

The Congress then adjourned.

PROCEEDINGS OF THE CHAMBER OF DELEGATES.

The Preliminary Meeting:—The Chamber of Delegates was called to order at 5 P. M., August 21st, by Dr. T. C. Mendenhall, and Prof. H. S. Carhart was made temporary secretary. The Chair appointed the following committee on credentials and permanent organization: H. S. Carhart, T. C. Mendenhall, Elihu Thomson, E. Mascart, W. H. Preece, Dr. Budde, Prof. Ferraris. The Chamber then adjourned to 4 P. M. on the following day.

MEETING OF AUGUST 22ND.

The meeting was called to order by Dr. Mendenhall. Chairman Carhart of the committee on credentials reported the list of duly accredited delegates.¹

For the committee on permanent organization, the Chairman (Carhart) reported the following nominations: For President, Prof. H. A. Rowland; for permanent Secretary, Dr. E. L. Nichols. By common consent, English was adopted as the official language of the Chamber. The question was raised by Dr. Sahulka as to the right of delegations to fill vacancies. Dr. Mendenhall presented the following motion, which was carried unanimously:

Each nation shall be entitled to as many votes as the number of delegates to which it was entitled by the original plan of organization. When members of a delegation shall differ on any question, each shall be entitled to cast his proportion of the vote of his government, counting only those present in the Chamber at the time.

Dr. von Helmholtz requested the admission of certain gentlemen on the ground of their intimate acquaintance with questions to come before the chamber. It was moved that with the approval of the President and Secretary, any persons approved by members may be admitted as visitors without the right to vote or to take part in the discussions. [Carried.] In accordance with this resolution Mr. Preece requested the admission of Messrs. Carl Hering and A. E. Kennelly; Dr. von Helmholtz requested the admission of Messrs. Lindeck, Feussner, Pringsheim, and Leman. Prof. Ferraris requested the admission of Mr. Grassi of Milan. All these requests were approved by the President and

1. See list on the page after the title page.

the Secretary. Mr. Preece moved that the Congress be asked to consider nomenclature and notation. Mr. Siemens offered to amend as follows:

That the order of business presented in the printed programme be adopted as the order of proceedings. All proposals on which a prolonged discussion arises, may be postponed by the President so that the points accepted by all parties may be settled with as little delay as possible.

The motion as amended was carried unanimously.

The Chamber then entered upon the order of business. Mr. Preece reported the work done in England, upon resistance, current and electromotive force. Mr. Budde presented a similar report from the Elektrotechnische Verein, of Berlin. Prof. Carhart presented the following resolution:

Resolved, That the several governments represented by delegates in this International Congress of Electricians be, and are hereby, recommended to formally adopt as a legal unit of resistance, the following, viz:

The resistance offered to an unvarying electric current by a column of mercury at the temperature of melting ice, 14.4521 grammes in mass of a constant cross sectional area and of length of 106.8 centimetres."

The motion was carried.

Dr. von Helmholtz laid before the Chamber the report of the Physikalische-technische Reichs-anstalt upon the official German practical standard of light (the Heffner lamp). Prof. Ayrton proposed the adoption of a definition of current taken from the report previously referred to by Mr. Preece. It was moved to defer the further consideration of Prof. Ayrton's motion until the opening of Wednesday's session. Dr. Mendenhall offered the following modification of the conditions, under which visitors might be admitted to the Chamber:

"No persons not members shall be admitted to the sittings except as may be recommended by delegates, and whose presence will in the judgment of the President and the Secretary be of value to the Chamber."

[Carried.]

Dr. von Helmholtz moved that the next session be held at 3 p. m. on Wednesday, August 23d. [Adjourned].

MEETING OF AUGUST 23D.

The session was called to order by President Rowland, all the delegates excepting Mr. Weber being present. Upon motion of the committee on credentials, Mr. A. M. Chavez, representing Mexico, was added to the list of members. It was agreed to extend to Dr. Elisha Gray as Chairman of the General Congress the privilege of attendance upon the Chamber. Dr. S. P. Thompson suggested the printing of the minutes [no action]. Dr. Mendenhall offered a substitution for Prof. Ayrton's definition of the ampere, involving also a modification of definition of the ohm and volt. A motion to reconsider the definition of the ohm was carried. Prof. Ayrton moved the appointment of a committee, with the President as chairman, to frame definitions of the ohm, ampere and volt. The vote upon this motion was as follows: Ayes; United States 5, England 5, France 3, Germany 1, Switzerland 3, Sweden 1, Canada 1, Total 19. Noes; Germany

4, Italy 3, Mexico 1, Total 8. [The motion was carried]. Upon motion of Mr. Preece, the president appointed as members of this committee, Messrs. von Helmholtz, Mascart, Ayrton and Mendenhall. Remarks upon the definitions of the ampere and volt were made by Messrs. von Helmholtz, Rowland and Mascart and Ayrton. Mr. Preece requested the substitution of Mr. Siemens for himself upon the committee for notation and nomenclature, also that Mr. Sahulka be added to that committee. Mr. Preece moved the appointment of a committee on light to consist of the following members: Messrs. Violle, S. P. Thompson, Nichols, Budde, Lummer and Palaz. The Chamber adjourned to meet at 2 P.M. on Thursday.

MEETING OF AUGUST 24.

Absent, Messrs. Schröder and Weber. The minutes of the previous meeting were read and approved. The report of the committee on the ohm, ampere and volt, was received, Mr. Mendenhall reporting as follows:

Resolved, That the several governments represented by delegates in this International Congress of Electricians be, and they are hereby recommended to formally adopt as legal units of electrical measure the following:

As a unit of resistance, the *international ohm*, which is based upon the ohm, equal to 10^9 units of resistance of the c. g. s. system of electro-magnetic units, and is represented by the resistance offered to an unvarying electric current by a column of mercury at the temperature of melting ice, 14,4521 grammes in mass of a constant cross-sectional area and of a length of 106.8 centimetres.

As a unit of current, the *international ampere*, which is one-tenth of the unit of current of the c. g. s. system of electro-magnetic units, and which is represented sufficiently well for practical use by the unvarying current which, when passed through a solution of nitrate of silver in water, in accordance with accompanying specifications, deposits silver at the rate of 0.001118 of a gramme per second.

As a unit of electromotive force, the *international volt*, which is the electromotive force that, steadily applied to a conductor whose resistance is one international ohm, will produce a current of one international ampere, and which is represented sufficiently well for practical use by $\frac{1}{10}$ of the electromotive force between the poles or electrodes of the voltaic cell, known as Clark's cell; at a temperature of 15 degrees C. and prepared in the manner described in the accompanying specification.¹

As a unit of quantity the *international coulomb*, which is the quantity of electricity transferred by a current of one international ampere in one second.

As a unit of capacity, the *international farad*, which is the capacity of a condenser charged to a potential of one international volt by one international coulomb of electricity."

The report of the committee was unanimously adopted.

The President announced as the next order of business the consideration of the remaining electrical units. Prof. Mascart made the motion to accept the name of *Henry* for the practical unit of induction, "which shall be the quantity to which the name of quadrant was given by the congress of 1889." The motion was seconded by Prof. Ayrton. It was proposed to divide the question.

1. The specifications referred to are those of the British Board of Trade, the specifications for the Clark cell to be modified by a committee which has not yet reported.

The motion of Prof. Mascart, that the practical unit of the coefficient of induction shall be called the Henry, was then carried unanimously.

Mr. Preece moved that the definition of the Henry be referred to the following committee: Messrs. Rowland, Ferraris, Ayrton, Budde, Carhart, and Hospitalier. [Carried.]

Prof. Ferraris offered the following definitions of the units of work and power.

As a unit of work, the joule, which is equal to 10^7 units of work in the c. g. s. system and which is represented sufficiently well for practical use by the energy expended in one second by an international ampere in an international ohm.

As a unit of power, the watt, which is equal to 10^7 units of power in the c. g. s. system and which is represented sufficiently well for practical use by work done at the rate of one joule per second.

The President in introducing the next order of business (magnetic units), proposed that no more units on the practical system be established. It was moved by Mr. Siemens that for magnetic units the c. g. s. system be commended and that for the present no names be given to these units. [Carried.]

The question of the standardization of arc lamps was then taken up. It was moved by Dr. Nichols that, owing to the uncertain and complicated nature of arc light photometry, the Chamber recommend that, in making specifications or contracts for arc lighting, the performance of a lamp should be indicated in terms of volts and amperes. After some discussion it was determined that this was not a matter of international importance and the motion was laid upon the table. The Chamber adjourned to meet at 2 o'clock on Friday.

MEETING OF AUGUST 25.

The report of the committee upon standards of light was read by Dr. S. P. Thompson. It was moved by Mr. Preece and seconded by Prof. Ayrton that the report be adopted. The motion was unanimously carried.

The following is the report of the committee:

The committee appointed to consider standards of light, beg to submit the following report.

They have had much discussion upon the various forms suggested for practical standards, and in particular upon the two special forms of lamp known respectively as the amyl-acetate lamp, of von Heffner-Alteneck, and the pentane lamp, of Vernon Harcourt. The only practical lamp actually presented to the committee, is the new von Heffner lamp, which, though it has been laboriously tested at the Reichs-anstalt, and reported accurate within two per cent., has not received any extended trial in other lands. On the other hand it was reported that the pentane lamp in its recent improved form was preferred in England for the photometry of gas lights. There is the objection to the pentane lamp that the composition of commercial pentane is not sufficiently well defined: and to the amyl-acetate lamp that its color is too red in hue. Finally objections are taken to all open flame lamps: that they are too liable to be influenced by changes in the pressure, temperature and moisture of the

air. It is admitted, on the other hand, that no electric lamp suitable for use as a convenient practical standard, has yet been realized. Under these circumstances there was a sharp division of opinion in the committee, between those who advocated the von Hefner lamp as an independent standard and those who desired to maintain the status quo, until further researches should have been made in various countries. It was proposed by Drs. Budde and Lummer that the von Hefner lamp, constructed exactly according to the specifications of Mr. von Hefner-Alteneck be introduced as a provisional practical standard of light, and that the problem of determining its value in terms of the absolute unit be left to subsequent investigation.

On vote this was lost by two votes for and four against. The following motion, proposed by Messrs. Palaz and Thompson and amended by Drs. Budde and Lummer, was then carried unanimously. *Resolved*, That this committee while recognizing the great progress realized in the standard lamp of von Hefner-Alteneck, and the very important researches made at the Reichsanstalt, also recognizes that other standards have been proposed and are now being tried, and that there are serious objections to every kind of standard, in which an open flame is employed. It is, therefore, unable to recommend the adoption at the present time of either the von Hefner lamp or the pentane lamp, but recommends that all nations be invited to make researches in common on well-defined practical standards, and on the convenient realization of the absolute unit.

Prof. Ayrton then read the report of the committee on the definition of the Henry, which was duly adopted.

The definition was as follows: As a unit of induction the henry is recommended, which is the induction in a circuit when the electromotive force induced in this circuit is one international volt, while the inducing current varies at the rate of one ampere per second.

The report of the committee on notation and nomenclature was presented. After discussion, it was moved by Mr. Preece and seconded by Mr. Siemens that the report be received as the work of the committee dealing with the subject, and that it be printed as an appendix to the proceedings of the Chamber. The motion was carried. The Chamber then adjourned to meet at Victoria House, World's Fair Grounds, at 10 A. M. on Saturday, August 26, 1893.

MEETING OF AUGUST 26, 1893.

The meeting was called to order by President Rowland, at Victoria House, World's Fair Grounds, at 11 A. M.

The minutes of all previous sittings of the Chamber were read, and after certain corrections, were declared correct.

It was moved that the specifications referred to in the definition of units be those in the printed report of the British Board of Trade.

Dr. von Helmholtz called attention to desirable changes in the specifications referring to the Clark's cell.

Dr. Mendenhall moved the appointment of a committee of three to be empowered to draw up the specifications in question; the committee to consist of Messrs. von Helmholtz, Ayrton and Carhart.

Mr. Preece called the attention of the chamber to the system of notation presented by Prof. Jamieson for their consideration.

The Secretary distributed printed slips containing the same.

The Chamber adjourned.

As the above resolutions are somewhat confused by being mixed with the general proceedings of the Chamber of Delegates, the actual recommendations are given in separate form, as follows :

FINAL AND OFFICIAL RECOMMENDATION OF THE CHAMBER OF DELEGATES.

Resolved, That the several governments represented by the delegates of this International Congress of Electricians be, and they are hereby, recommended to formally adopt as legal units of electrical measure the following : As a unit of resistance, the *international ohm*, which is based upon the ohm equal to 10^9 units of resistance of the c. g. s. system of electromagnetic units, and is represented by the resistance offered to an unvarying electric current by a column of mercury at the temperature of melting ice 14.4521 grammes in mass, of a constant cross-sectional area and of the length of 106.8 centimetres.

As a unit of current, the *international ampere*, which is one-tenth of the unit of current of the c. g. s. system of electro-magnetic units, and which is represented sufficiently well for practical use by the unvarying current which, when passed through a solution of nitrate of silver in water, and in accordance with accompanying specifications,¹ deposits silver at the rate of 0.001118 of a gramme per second.

As a unit of electromotive force, the *international volt*, which is the electromotive force that, steadily applied to a conductor whose resistance is one international ohm, will produce a current of one international ampere, and which is represented sufficiently well for practical use by $\frac{1}{1000}$ of the electromotive force between the poles or electrodes of the voltaic cell known as Clark's cell, at a temperature of 15° c., and prepared in the manner described in the accompanying specification.²

As a unit of quantity, the *international coulomb*, which is the quantity of electricity transferred by a current of one international ampere in one second.

As a unit of capacity, the *international farad*, which is the capacity of a condenser charged to a potential of one international volt by one international coulomb of electricity.

1. In the following specification the term silver voltameter means the arrangement of apparatus by means of which an electric current is passed through a solution of nitrate of silver in water. The silver voltameter measures the total electrical quantity which has passed during the time of the experiment, and by noting this time the time average of the current, or, if the current has been kept constant, the current itself can be deduced.

In employing the silver voltameter to measure currents of about one ampere, the following arrangements should be adopted :

The kathode on which the silver is to be deposited should take the form of a platinum bowl not less than 10 centimetres in diameter and from 4 to 5 centimetres in depth.

The anode should be a plate of pure silver some 30 square centimetres in area and 2 or 3 millimetres in thickness.

This is supported horizontally in the liquid near the top of the solution by a platinum wire passed through holes in the plate at opposite corners. To prevent the disintegrated silver which is formed on the anode from falling onto the kathode, the anode should be wrapped round with pure filter paper, secured at the back with sealing wax.

The liquid should consist of a neutral solution of pure silver nitrate, containing about 15 parts by weight of the nitrate to 85 parts of water.

The resistance of the voltameter changes somewhat as the current passes. To prevent these changes having too great an effect on the current, some resistance besides that of the voltameter should be inserted in the circuit. The total metallic resistance of the circuit should not be less than 10 ohms.

2. A committee consisting of Messrs. Helmholtz, Ayrton and Carhart, was appointed to prepare specifications for the Clark's cell. Their report has not yet been received.

As a unit of work, the *joule*, which is equal to 10^7 units of work in the c. g. s. system, and which is represented sufficiently well for practical use by the energy expended in one second by an international ampere in an international ohm.

As a unit of power, the *watt*, which is equal to 10^7 units of power in the c. g. s. system, and which is represented sufficiently well for practical use by work done at the rate of one joule per second.

As the unit of induction, the *henry*, which is the induction in a circuit when the electromotive force induced in this circuit is one international volt, while the inducing current varies at the rate of one ampere per second,

PROCEEDINGS OF SECTION A.

Section A, to which was committed the department of Pure Theory, met in Room 6 at the Art Institute, on Tuesday, August 22d, and was called to order at 10 o'clock A. M. by Prof. H. A. Rowland, of Johns Hopkins University.

The following officers were then nominated and unanimously elected :

Chairman, Prof. H. A. Rowland, of Johns Hopkins University.

Vice-Chairman, Prof. Galileo Ferraris, of Italy.

Secretary, Prof. A. L. Kimball, of Amherst College.

Sectional Committee : Prof. A. G. Webster, of Clark University; Alexander Macfarlane, of the University of Texas; Charles P. Steinmetz, of Yonkers, N. Y.

A permanent organization being effected, Chairman Rowland said : We meet here for a discussion of pure science and all will take part in the proceedings. I will ask Prof. Ferraris to say a few words.

Prof. Ferraris was received with hearty applause and addressed the section as follows :

I am not accustomed to speaking English, and I do not know that I will be able to express readily my thoughts to you. I have difficulty in public speaking in my own language, and it is much more difficult for me to speak in English. I may almost say it is absolutely impossible. Therefore, I pray you, where you do not understand me, to suppose what I would say.

This is my first visit to America. I came here in order to see the New World, where scientific ideas find great applications which result in splendid advancement. I came to take part in the sessions of the Congress which occupy themselves with pure science. It is apparently a contradiction, but it is not a contradiction in fact. The science of electricity is the science, which better than any other, has demonstrated the mutual relation of pure science and practice, and especially here in America it is difficult—it is impossible—to divide science from practice. It is not only in theory but in the great practice which has been developed here, and in their love for science that the great Ameri-

can people exhibit the wonderful results achieved by them in technical science and material wealth.

You see the difficulty with which I express myself in a tongue which is not native to me, but I promise you that I will contribute to the full extent of my power to the objects of the Congress. I thank you for your kindness.

The meeting then adjourned until 10 A. M. the following day.

MEETING OF WEDNESDAY, AUGUST 23D.

The meeting was called to order at 10 A. M. by Chairman Rowland.

The first paper on "The Analytical Treatment of Alternating Currents," by Prof. A. Macfarlane was as follows:

ON THE ANALYTICAL TREATMENT OF ALTERNATING CURRENTS.

BY PROF. A. MACFARLANE, UNIVERSITY OF TEXAS, AUSTIN, TEXAS.

In a recently published work on "Alternating Currents," Messrs. Bedell and Crehore present a double treatment of the subject—an analytical and a graphical. With respect to the relative efficiency of the two methods they say (Preface, p. 2), "There are some to whom graphical methods appeal more strongly than analytical processes, and the cases of simple circuits have accordingly been fully treated in both ways. The problems of divided circuits and networks of conductors yield the more readily to graphical treatment, inasmuch as analytical methods necessarily become cumbersome and involved, and do not appeal directly to the senses." The authors (p. 211) present a paradox which amounts to the following: that analysis is required to investigate the fundamental principles, but graphics are required to make the applications.

I propose to show that the defects of the analytical method are due to the fact that it is not the natural, but a restricted, analysis which is applied. The natural analysis starts from the graphic method as a mere basis: consequently it must be much more powerful. The natural analysis for the subject of alternating currents is not line algebra but plane algebra. By plane algebra is meant the algebra of "complex quantities," but treated so as to harmonize with the more general algebra of space. That the method of "complex quantities" has here an application, has been pointed out by Mr. Kennelly in his paper on Impedance¹. "Any combination of resistances,

1. Trans. Am. Inst. El. Eng., vol. x., p. 184.

non-ferric inductances, and capacities, carrying harmonically alternating currents, may be treated by the rules of unvarying currents, if the inductances are considered as resistances of the form $p l \sqrt{-1}$, and the capacities as resistances of the form $-\frac{1}{k p} \sqrt{-1}$, the algebraic operations being then performed according to the laws controlling complex quantities." It is the purpose of this paper to show that not only the applications but the fundamental principles are more readily obtained by plane algebra.

In plane algebra the quantities considered can be represented by vectors lying in a common plane, and the relation considered is that which may exist between one vector and another. Let **A** and **B** be two such vectors lying in the plane of the paper; the axis of this plane is constant and may be denoted by a . In

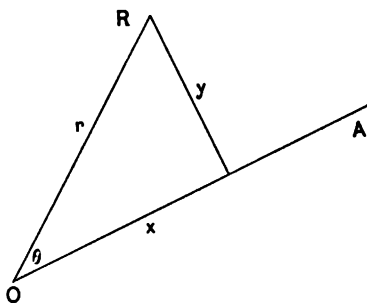

the more general algebra of space, a varies, hence must always be stated explicitly. The ratio of **B** to **A** consists of a change of length which may be denoted by r , and a change of direction which may be denoted by a^θ , that is, a turning of θ radians round the axis a . Thus

$$\mathbf{B} = r a^\theta \mathbf{A}$$

and reciprocally
$$\mathbf{A} = \frac{1}{r} a^{-\theta} \mathbf{B}$$

The ratio or rotator $r a^\theta$ is a directed quantity but it is not a vector; in order to distinguish it as a whole it may be denoted by a small black letter as r . Each of the vectors in the plane may be specified by such a rotator, a given initial vector being understood. The confusion of such rotator with the rotated line has been the principal cause of the obscurity which has clouded the algebra of complex numbers.

The turning factor α^θ may be expressed as the sum of two ratios, of which one involves a zero angle, and the other an angle of a quadrant. Thus

$$\alpha^\theta = \cos \theta + \sin \theta \cdot \alpha^{\frac{\pi}{2}}$$

Hence

$$r \alpha^\theta = r \cos \theta + r \sin \theta \cdot \alpha^{\frac{\pi}{2}}$$

$$= x + y \cdot \alpha^{\frac{\pi}{2}}$$

where x and y denote the rectangular co-ordinates of the extremity of \mathbf{R} relative to \mathbf{A} and a perpendicular to \mathbf{A} as axes. Hence

$$r = \sqrt{x^2 + y^2} \text{ and } \theta = \tan^{-1} \frac{y}{x}$$

In the method of complex numbers $\alpha^{\frac{\pi}{2}}$ is expressed by i or j which stand for $\sqrt{-1}$. The advantages of using the above notation are that it is capable of being applied to space, and that it also serves to specify the general rotator α^θ as well as the rectangular rotator $\alpha^{\frac{\pi}{2}}$ which is here the meaning of $\sqrt{-1}$.

From the relation of \mathbf{R} to \mathbf{A} the reciprocal relation of \mathbf{A} to \mathbf{R} is derived thus

$$\mathbf{A} = \frac{1}{r} \alpha^{-\theta} \mathbf{R}$$

$$= \frac{1}{x + y \cdot \alpha^{\frac{\pi}{2}}} \mathbf{R}$$

$$= \frac{x - y \cdot \alpha^{\frac{\pi}{2}}}{x^2 + y^2} \mathbf{R}$$

If the ratio to \mathbf{A} of each of several vectors is given, the ratio to \mathbf{A} of their resultant is obtained by taking the sum of the ratios. Thus if

$$\mathbf{R}_1 = r_1 \alpha^{\theta_1} \mathbf{A} = (x_1 + y_1 \alpha^{\frac{\pi}{2}}) \mathbf{A}$$

$$\mathbf{R}_2 = r_2 \alpha^{\theta_2} \mathbf{A} = (x_2 + y_2 \alpha^{\frac{\pi}{2}}) \mathbf{A}$$

... ..

$$\mathbf{R}_n = r_n \alpha^{\theta_n} \mathbf{A} = (x_n + y_n \alpha^{\frac{\pi}{2}}) \mathbf{A}$$

then $\Sigma \mathbf{R} = \Sigma (r a^\theta) \mathbf{A}$

$$= R a^\varphi \mathbf{A}$$

where $R^2 = \Sigma r^2 + 2 \Sigma r_1 r_2 \cos (\theta_1 - \theta_2)$

and $\varphi = \tan^{-1} \frac{\Sigma (r \sin \theta)}{\Sigma (r \cos \theta)}$

also $\Sigma \mathbf{R} = \{ \Sigma x + (\Sigma y) \cdot a^{\frac{\pi}{2}} \} \mathbf{A}$

and reciprocally $\mathbf{A} = \frac{\Sigma x - (\Sigma y) \cdot a^{\frac{\pi}{2}}}{(\Sigma x)^2 + (\Sigma y)^2} \Sigma \mathbf{R}$

It is to be noticed that Σ applied to a vector means a geometrical summation.

If the ratio of \mathbf{R} to \mathbf{A} and of \mathbf{R}^1 to \mathbf{R} are given, the ratio of \mathbf{R}^1 to \mathbf{A} is found by taking the product of the ratios. Thus

if $\mathbf{R} = r a^\theta \mathbf{A} = (x + y \cdot a^{\frac{\pi}{2}}) \mathbf{A}$

and $\mathbf{R}^1 = r^1 a^{\theta_1} \mathbf{R} = (x^1 + y^1 \cdot a^{\frac{\pi}{2}}) \mathbf{R}$

then $\mathbf{R}^1 = r r^1 a^{\theta + \theta_1} \mathbf{A} = \{ x x^1 - y y^1 + (x^1 y + x y^1) \cdot a^{\frac{\pi}{2}} \} \mathbf{A}$

But if $\mathbf{R} = r a^\theta \mathbf{A} = (x + y \cdot a^{\frac{\pi}{2}}) \mathbf{A}$

and $\mathbf{R}^1 = r^1 a^{\theta_1} \mathbf{A} = (x^1 + y^1 \cdot a^{\frac{\pi}{2}}) \mathbf{A}$

then $\mathbf{R}^1 = \frac{r^1 a^{\theta_1 - \theta}}{r} \mathbf{R} = \frac{x x^1 + y y^1 + (x y^1 - x^1 y) \cdot a^{\frac{\pi}{2}}}{x^2 + y^2} \mathbf{R}$

The index notation a^θ is not fanciful, but analytically correct.

For $\log a^\theta = \theta \log_e a^1 = \theta \cdot a^{\frac{\pi}{2}}$; so that $a^\theta = e^{\theta \cdot a^{\frac{\pi}{2}}}$ which is the determinate expression for $e^{\theta \sqrt{-1}}$. Hence*

$$r a^\theta = r e^{\theta \cdot a^{\frac{\pi}{2}}} = e^{\log r + \theta \cdot a^{\frac{\pi}{2}}}$$

The ratio $r a^\theta$ is differentiated with respect to time in the following manner:

$$\frac{d}{dt} (r a^\theta) = \frac{d r}{d t} \cdot a^\theta + r \frac{d (a^\theta)}{d t}$$

*On account of the small size of letters, the Greek letter alpha is written α in the exponents to distinguish from a .

but
$$a^\theta = \cos \theta + \sin \theta \cdot a^{\frac{\pi}{2}}$$
and
$$\frac{d(a^\theta)}{dt} = (-\sin \theta + \cos \theta \cdot a^{\frac{\pi}{2}}) \frac{d\theta}{dt}$$

$$= a^{\theta + \frac{\pi}{2}} \frac{d\theta}{dt}$$

hence
$$\frac{d}{dt} (r a^\theta) = \frac{dr}{dt} a^\theta + r \frac{d\theta}{dt} a^{\theta + \frac{\pi}{2}}$$

When a is not constant, the differentiation is more complex.

Hence
$$\frac{d}{dt} e^{(a+b \cdot a^{\frac{\pi}{2}}) t} = e^{(a+b \cdot a^{\frac{\pi}{2}}) t} (a + b \cdot a^{\frac{\pi}{2}})$$

$$= \sqrt{a^2 + b^2} e^{(a+b \cdot a^{\frac{\pi}{2}}) t} a^{\tan^{-1} \frac{b}{a}}$$

and conversely
$$\int e^{(a+b \cdot a^{\frac{\pi}{2}}) t} = e^{(a+b \cdot a^{\frac{\pi}{2}}) t} \frac{1}{a + b \cdot a^{\frac{\pi}{2}}}$$

$$= e^{(a+b \cdot a^{\frac{\pi}{2}}) t} \frac{a - b \cdot a^{\frac{\pi}{2}}}{a^2 + b^2}$$

$$= \frac{1}{a^2 + b^2} e^{(a+b \cdot a^{\frac{\pi}{2}}) t + \tan^{-1} \frac{b}{a} \cdot a^{\frac{\pi}{2}}}$$

$$= \frac{e^{at}}{a^2 + b^2} e^{(b t + \tan^{-1} \frac{b}{a}) \cdot a^{\frac{\pi}{2}}}$$

In plane algebra the fundamental rules of operation are the same as those for line algebra, as is exemplified in the above rules for differentiating or integrating an exponential function. But when the vectors are in space, the rules require to be generalized.

When this analysis is applied, the investigation of the fundamental principles of alternating currents is much simplified. We shall apply it to the case of a circuit containing resistance and self-induction. The differential equation in the case of a circuit containing resistance and self-induction, the electromotive force being simple harmonic, is

$$\frac{di}{dt} + \frac{R}{L} i = \frac{E}{L} \sin \omega t$$

Now $E \sin \omega t$ is the sine component of $E a^{\omega t}$ and i is the sine component of a ratio $\mathbf{i} = r a^{\theta}$. It is more difficult to treat of the sine component than of the complete ratio, and to this circumstance is due many of the obscure transformations encountered in the solution of linear differential equations. The complete equation is

$$\frac{d\mathbf{i}}{dt} + \frac{R}{L} \mathbf{i} = \frac{E}{L} a^{\omega t}$$

Because the fundamental rules of plane algebra are the same as those for line algebra, the solution has the same form as before, namely

$$\mathbf{i} = \frac{E}{L} e^{-\frac{Rt}{L}} \int e^{\frac{Rt}{L}} a^{\omega t} dt + \mathbf{c} e^{-\frac{Rt}{L}}$$

But
$$\int e^{\frac{Rt}{L}} a^{\omega t} dt = \int e^{\left(\frac{R}{L} + \omega \cdot \alpha^{\frac{\pi}{2}}\right)t} dt$$

$$= \frac{e^{\left(\frac{R}{L} + \omega \cdot \alpha^{\frac{\pi}{2}}\right)t}}{\frac{R}{L} + \omega \cdot \alpha^{\frac{\pi}{2}}}$$

$$= \frac{e^{\left(\frac{R}{L} + \omega \cdot \alpha^{\frac{\pi}{2}}\right)t} \left(\frac{R}{L} - \omega \cdot \alpha^{\frac{\pi}{2}}\right)}{\left(\frac{R}{L}\right)^2 + \omega^2}$$

$$= e^{\left(\frac{R}{L} + \omega \cdot \alpha^{\frac{\pi}{2}}\right)t} \frac{1 - \tan^{-1} \frac{L\omega}{R}}{e^{\frac{L\omega}{R}} \sqrt{\frac{R^2}{L^2} + \omega^2}}$$

therefore
$$\mathbf{i} = \frac{E}{\sqrt{R^2 + L^2 \omega^2}} e^{\left(\omega t - \tan^{-1} \frac{L\omega}{R}\right) \alpha^{\frac{\pi}{2}}} + \mathbf{c} e^{-\frac{Rt}{L}}$$

$$= \frac{E}{\sqrt{R^2 + L^2 \omega^2}} a^{\omega t - \tan^{-1} \frac{L\omega}{R}} + \mathbf{c} e^{-\frac{Rt}{L}}$$

Finally, by taking the sine component of either side

$$i = \frac{E}{\sqrt{R^2 + L^2 \omega^2}} \sin \left(\omega t - \tan^{-1} \frac{L\omega}{R} \right) + \mathbf{c} e^{-\frac{Rt}{L}}$$

When the term $\mathbf{c} e^{-\frac{R t}{L}}$ disappears we have

$$\begin{aligned} \mathbf{i} &= \frac{a^{-\tan^{-1} \frac{L \omega}{R}}}{\sqrt{R^2 + L^2 \omega^2}} E a^{\omega t} \\ &= \frac{R - L \omega a^{\frac{\pi}{2}}}{R^2 + L^2 \omega^2} \mathbf{e} \\ &= \frac{1}{R + L \omega a^{\frac{\pi}{2}}} \mathbf{e} \end{aligned}$$

and reciprocally $\mathbf{e} = (R + L \omega a^{\frac{\pi}{2}}) \mathbf{i}$

In the case of a compound circuit composed of a number of simple circuits in series, if

$$\begin{aligned} \mathbf{e}_1 &= (R_1 + L_1 \omega a^{\frac{\pi}{2}}) \mathbf{i} \\ \mathbf{e}_2 &= (R_2 + L_2 \omega a^{\frac{\pi}{2}}) \mathbf{i} \\ \text{etc.} & \qquad \qquad \text{etc.} \end{aligned}$$

then, adding, $\Sigma \mathbf{e} = \left\{ \Sigma R + (\Sigma L) \omega a^{\frac{\pi}{2}} \right\} \mathbf{i}$

and reciprocally

$$\mathbf{i} = \frac{\Sigma R - (\Sigma L) \omega a^{\frac{\pi}{2}}}{(\Sigma R)^2 + (\Sigma L)^2 \omega^2} \Sigma \mathbf{e}$$

In the case of a compound circuit composed of a number of simple circuits in parallel,

$$\begin{aligned} \mathbf{i}_1 &= \frac{R_1 - L_1 \omega a^{\frac{\pi}{2}}}{R_1^2 + L_1^2 \omega^2} \mathbf{e} \\ \mathbf{i}_2 &= \frac{R_2 - L_2 \omega a^{\frac{\pi}{2}}}{R_2^2 + L_2^2 \omega^2} \mathbf{e} \\ \text{etc.} & \qquad \qquad \text{etc.} \end{aligned}$$

therefore $\Sigma \mathbf{i} = \Sigma \left\{ \frac{R - L \omega a^{\frac{\pi}{2}}}{R^2 + L^2 \omega^2} \right\} \mathbf{e}$

$$= \left[\Sigma \left(\frac{R}{R^2 + L^2 \omega^2} \right) - \omega \Sigma \left(\frac{L}{R^2 + L^2 \omega^2} \right) a^{\frac{\pi}{2}} \right] \mathbf{e}$$

and reciprocally

$$e = \frac{\Sigma \left(\frac{R}{R^2 + L^2 \omega^2} \right) + \omega \Sigma \left(\frac{L}{R^2 + L^2 \omega^2} \right) \cdot a^{\frac{\pi}{2}}}{\left(\Sigma \frac{R}{R^2 + L^2 \omega^2} \right)^2 + \omega^2 \left(\Sigma \frac{L}{R^2 + L^2 \omega^2} \right)^2} \Sigma i.$$

DISCUSSION.

THE CHAIRMAN:—The discussion of this paper is now in order.

PROF. JOHN E. DAVIES:—Prof. Macfarlane, I understand, included at the outset the effects of capacity in the other terms.

It occurred to me that we should specify in the final formulæ what parts were due to resistance, what to inductance and what parts due to capacity, separately.

It seems as if we ought to be able at once to identify in our final formulæ the effects of each of these causes by itself when we so desire.

DR. FREDERICK BEDELL:—As Prof. Macfarlane has pointed out, there is quite a necessity, I think, of some more comprehensive system of analysis than that ordinarily employed, which, although adequate for the treatment of a single series circuit and some of the simple cases of divided circuit, becomes exceedingly cumbersome in the more complex cases of combined circuits. For the solution of these latter cases, the graphical method is the more readily understood, but this is because our system of analysis is not perfect. A basis for a better system of analysis may be found in these graphical methods themselves, so that the graphical processes may be analytically expressed by a proper notation, that is, we may omit the diagrams and still follow the processes. An illustration of this is found in the method for obtaining the equivalent resistance, self-induction and capacity of parallel circuits.

We have looked with pleasure at the development of the compact system of notation just explained and look to its further generalized application to complex combinations of circuits, containing not only resistance and self-induction, as in the case just illustrated, but also capacity and mutual induction.

PROF. MACFARLANE:—In reply to the question of Dr. Davies, the capacity merely adds a negative term to the vertical component. It merely generalizes the above and does not involve anything very different in analysis. I did not take the more complex case but took the simplest case where the principles of the method would be best seen. The principle of the method is what I wanted to dwell upon, and not any particular difficulty in it, in order to show that the simplest problem could be treated in that way. Of course, the method applies readily to more

complex cases as Dr. Bedell has stated. Another advantage of this notation is it applies to space as well as to a plane.

THE CHAIRMAN:—There is no doubt about the importance of this subject in the present stage of electrical science.

We are coming more and more to use these complex quantities instead of using sines and cosines, and we find great advantage in their use for calculating all problems of alternating currents, and throughout the whole range of physics.

Anything that is done in this line is of great advantage to science.

The following paper by Mr. Steinmetz, was then read :

COMPLEX QUANTITIES AND THEIR USE IN ELECTRICAL ENGINEERING.

BY CHAS. PROTEUS STEINMETZ.

I.—INTRODUCTION.

In the following, I shall outline a method of calculating alternate current phenomena, which, I believe, differs from former methods essentially in so far, as it allows us to represent the alternate current, the sine-function of time, by a *constant* numerical quantity, and thereby eliminates the independent variable "time" altogether from the calculation of alternate current phenomena.

Herefrom results a considerable simplification of methods. Where before we had to deal with periodic functions of an independent variable, time, we have now to add, subtract, etc., constant quantities—a matter of elementary algebra—while problems like the discussion of circuits containing distributed capacity, which before involved the integration of differential equations containing *two* independent variables: "time" and "distance," are now reduced to a differential equation with *one* independent variable only, "distance," which can easily be integrated in its most general form.

Even the restriction to sine-waves, incident to this method, is no limitation, since we can reconstruct in the usual way the complex harmonic wave from its component sine-waves; though almost always the assumption of the alternate current as a true sine-wave is warranted by practical experience, and only under rather exceptional circumstances the higher harmonics become noticeable.

In the graphical treatment of alternate current phenomena different representations have been used. It is a remarkable fact, however, that the simplest graphical representation of

periodic functions, the common, well-known *polar coordinates*; with *time* as *angle* or *amplitude*, and the *instantaneous values* of the function as *radii vectores*, which has proved its usefulness through centuries in other branches of science, and which is known to every mechanical engineer from the Zeuner diagram of valve motions of the steam engine, and should consequently be known to every electrical engineer also, it is remarkable that this polar diagram has been utterly neglected, and even where it has been used, it has been misunderstood, and the sine-wave represented—instead of by one circle—by two circles, whereby the phase of the wave becomes indefinite, and hence the diagram

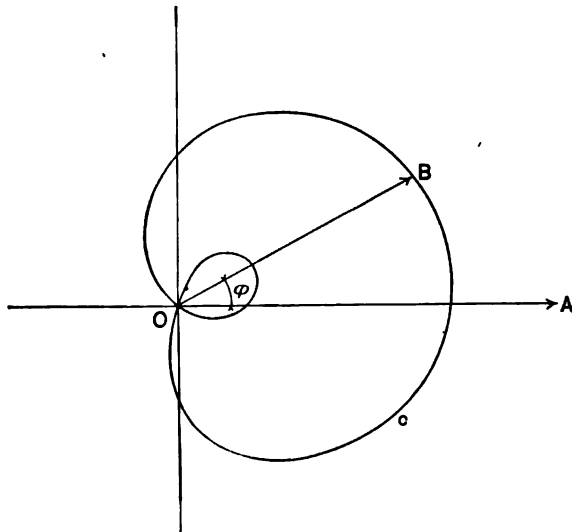

FIG. 1.

useless. In its place diagrams have been proposed, where revolving lines represent the instantaneous values by their projections upon a fixed line, etc., which diagrams evidently are not able to give as plain and intelligible a conception of the variation of instantaneous values, as a curve with the instantaneous values as radii, and the time as angle. It is easy to understand then, that graphical calculations of alternate current phenomena have found almost no entrance yet into the engineering practice.

In graphical representations of alternate currents, we shall make use, therefore, of the *Polar Coordinate System*, representing the *time* by the angle φ as amplitude, counting from an

initial radius \overline{OA} chosen as zero time or starting point, in positive direction or counter-clockwise,* and representing the time of one complete period by one complete revolution or $360^\circ = 2\pi$.

The instantaneous values of the periodic function are represented by the length of the radii vectores $\overline{OB} = r$, corresponding to the different angles φ or times t , and every periodic function is hereby represented by a closed curve (Fig. 1). At any time t , represented by angle or amplitude φ , the instantaneous value of the periodic function is cut out on the movable radius by its intersection \overline{OB} with the characteristic curve c of the func-

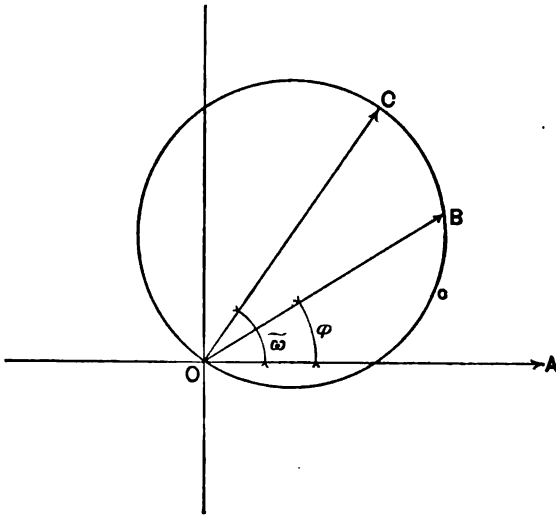

FIG. 2.

tion, and is positive, if in the direction of the radius, negative, if in opposition.

The *sine-wave* is represented by *one circle* (Fig. 2).

The diameter \overline{oo} of the circle, which represents the sine-wave, is called the *intensity* of the sine-wave, and its amplitude, $\overline{AOB} = \tilde{\omega}$, is called the *phase* of the sine-wave.

The sine-wave is completely determined and characterized by *intensity* and *phase*.

It is obvious, that the *phase* is of interest only as *difference of phase*, where several waves of different phases are under consideration.

*This direction of rotation has been chosen as positive, since it is the direction of rotation of celestial bodies.

Where only the *integral values* of the sine-wave, and not its *instantaneous values* are required, the characteristic circle c of the sine-wave can be dropped, and its diameter \overline{oc} considered as the representation of the sine-wave in the polar-diagram, and in this case we can go a step further, and instead of using the *maximum value* of the wave as its representation, use the *effective value*, which in the sine wave is $= \frac{\text{maximum value}}{\sqrt{2}}$.

Where, however, the characteristic circle is drawn with the *effective value* as diameter, the instantaneous values, when taken from the diagram, have to be enlarged by $\sqrt{2}$.

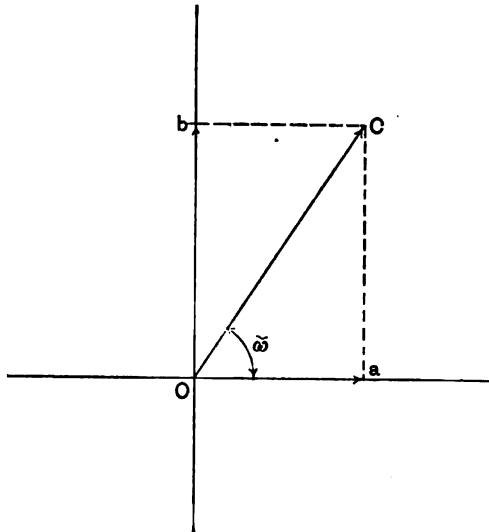

FIG. 3.

We see herefrom, that :

“In polar coordinates, the sine-wave is represented in intensity and phase by a vector \overline{oc} , and in combining or dissolving sine-waves, they are to be combined or dissolved by the parallelogram or polygon of sine-waves.”

For the purpose of calculation, the sine-wave is represented by two constants: C , $\tilde{\omega}$, intensity and phase.

In this case the combination of sine-waves by the Law of Parallelogram, involves the use of trigonometric functions.

The sine-wave can be represented also by its *rectangular coordinates*, a and b (Fig. 3), where :

$$\left. \begin{aligned} a &= C \cos \bar{\omega} \\ b &= C \sin \bar{\omega} \end{aligned} \right\}$$

Here a and b are the two *rectangular components of the sine-wave*.

This representation of the sine-waves by their rectangular components a and b is very useful in so far as it avoids the use of trigonometric functions. To combine sine-waves, we have simply to add or subtract their rectangular components. For instance, if a and b are the rectangular components of one sine-wave, a^1 and b^1 those of another, the resultant or combined sine-wave has the rectangular components $a + a^1$ and $b + b^1$.

To distinguish the horizontal and the vertical components of sine-waves, so as not to mix them up in a calculation of any greater length, we may mark the ones, for instance, the vertical components, by a distinguishing index, as for instance, by the addition of the letter j , and may thus represent the sine-wave by the expression:

$$a + j b$$

which means, that a is the horizontal, b the vertical component of the sine-wave, and both are combined to the resultant wave:

$$C = \sqrt{a^2 + b^2}$$

which has the phase:

$$\tan \bar{\omega} = \frac{b}{a}.$$

Analogous, $a - j b$ means a sine-wave with a as horizontal, and $-b$ as vertical component, etc.

For the first, j is nothing but a distinguishing index without numerical meaning.

A wave, differing in phase from the wave $a + j b$ by 180° , or one-half period, is represented in polar coordinates by a vector of opposite direction, hence denoted by the algebraic expression: $-a - j b$.

This means:

“*Multiplying the algebraic expression $a + j b$ of the sine-wave by -1 , means reversing the wave, or rotating it by $180^\circ =$ one-half period.*”

A wave of equal strength, but lagging $90^\circ =$ one-quarter period behind $a + j b$, has the horizontal component $-b$, and

the vertical component a , hence is represented algebraically by the symbol:

$$j a - b.$$

Multiplying, however; $a + j b$ by j , we get:

$$j a + j^2 b$$

hence, if we define the—until now meaningless—symbol j so, as to say, that:

$$j^2 = -1$$

hence:

$$j(a + j b) = j a - b,$$

we have:

“Multiplying the algebraic expression $a + j b$ of the sine-wave by j , means rotating the wave by 90° , or one-quarter period, that is, retarding the wave by one-quarter period.”

In the same way:

“Multiplying by $-j$, means advancing the wave by one-quarter period.”

$$j^2 = -1 \text{ means:}$$

$$j = \sqrt{-1}, \text{ that is:}$$

“ j is the imaginary unit, and the sine-wave is represented by a complex imaginary quantity $a + j b$.”

Herefrom we get the result:

“In the polar diagram of time, the sine-wave is represented in intensity as well as phase by one complex quantity:

$$a + j b,$$

where a is the horizontal, b the vertical component of the wave, the intensity is given by: $C = \sqrt{a^2 + b^2}$.

and the phase by: $\tan \tilde{\omega} = \frac{b}{a},$

and it is: $a = C \cos \tilde{\omega}$

$$b = C \sin \tilde{\omega}$$

hence the wave: $a + j b$ can also be expressed by:

$$C(\cos \tilde{\omega} + j \sin \tilde{\omega}).”$$

Since we have seen that sine-waves are combined by adding their rectangular components, we have:

“Sine-waves are combined by adding their complex algebraic expressions.”

For instance, the sine-waves:

$$a + j b$$

and

$$a^1 + j b^1$$

combined give the wave :

$$A + j B = (a + a') + j (b + b').$$

As seen, the combination of sine-waves is reduced hereby to the elementary algebra of complex quantities.

If $C = c + j c'$ is a sine-wave of alternate current, and r is the resistance, the E. M. F. consumed by the resistance is in phase with the current, and equal to current times resistance, hence it is :

$$r C = r c + j r c'.$$

If L is the "coefficient of self-induction," or $s = 2 \pi N L$ the "inductive resistance" or "ohmic inductance," which in the following shall be called the "inductance," the E. M. F. produced by the inductance (counter E. M. F. of self-induction) is equal to current times inductance, and lags 90° behind the current, hence it is represented by the algebraic expression :

$$j s C$$

and the E. M. F. required to overcome the inductance is consequently :

$$-j s C$$

that is, 90° ahead of the current (or, in the usual expression, the current lags 90° behind the E. M. F.).

Hence, the E. M. F. required to overcome the resistance r and the inductance s is :

$$(r - j s) C$$

that is :

" $I = r - j s$ is the expression of the impedance, in complex quantities, where $r =$ resistance, $s = 2 \pi N L =$ inductance."

Hence, if $C = c + j c'$ is the current, the E. M. F. required to overcome the impedance $I = r - j s$ is :

$$E = I C = (r - j s) (c + j c'), \text{ hence, since } j^2 = -1 : \\ = (r c + s c') + j (r c' - s c)$$

or, if $E = e + j e'$ is the impressed E. M. F., and $I = r - j s$ is the impedance, the current flowing through the circuit is :

$$C = \frac{E}{I} = \frac{e + j e'}{r - j s}$$

or, multiplying numerator and denominator by $(r + j s)$, to eliminate the imaginary from the denominator :

$$C = \frac{(e + j e') (r + j s)}{r^2 + s^2} = \frac{e r - e' s}{r^2 + s^2} + j \frac{e' r + e s}{r^2 + s^2}$$

If K is the *capacity* of a condenser, connected in series into a circuit of current $C = c + j c'$, the e. m. f. impressed upon the terminals of the condenser is $E = \frac{C}{2 \pi N K}$, and lags 90° behind the current, hence represented by :

$$E = j \frac{C}{2 \pi N K} = j k C,$$

where $k = \frac{1}{2 \pi N K}$ can be called the "*capacity inductance*" or simply "*inductance*" of the condenser. Capacity inductance is of opposite sign to magnetic inductance.

That means :

"If $r =$ resistance,

$L =$ coefficient of self-induction, hence $s = 2 \pi N L =$ inductance,

$K =$ capacity, hence $k = \frac{1}{2 \pi N K} =$ capacity inductance,

$I = r - j (s - k)$ is the impedance of the circuit, and Ohm's law is re-established :

$$E = I C,$$

$$C = \frac{E}{I},$$

$$I = \frac{E}{C}$$

in a more general form, however, giving not only the intensity, but also the phase of the sine-waves, by their expression in complex quantities."

In the following we shall outline the application of complex quantities to various problems of alternate and polyphase currents, and shall show that these complex quantities can be operated upon like ordinary algebraic numbers, so that for the solution of most of the problems of alternate and polyphase currents, elementary algebra is sufficient.

Algebraic operations with complex quantities :

$$j^2 = -1$$

$$a + j b = c (\cos \tilde{\omega} + j \sin \tilde{\omega})$$

$$c = \sqrt{a^2 + b^2},$$

$$\tan \tilde{\omega} = \frac{b}{a}.$$

If $a + j b = a^1 + j b^1$, it must be: $a = a^1, b = b^1$.

Addition and subtraction :

$$(a + j b) \pm (a^1 + j b^1) = (a \pm a^1) + j (b \pm b^1).$$

Multiplication :

$$(a + j b) (a^1 + j b^1) = (a a^1 - b b^1) + j (a b^1 + b a^1).$$

Division :

$$\frac{a + j b}{a^1 + j b^1} = \frac{(a + j b) (a^1 - j b^1)}{a^{12} + b^{12}} = \frac{a a^1 + b b^1}{a^{12} + b^{12}} + j \frac{a^1 b - a b^1}{a^{12} + b^{12}}.$$

Difference of phase between :

$$a + j b = c (\cos \bar{\omega} + j \sin \bar{\omega}) \text{ and,}$$

$$a^1 + j b^1 = c^1 (\cos \bar{\omega}^1 + j \sin \bar{\omega}^1):$$

$$\tan (\bar{\omega}^1 - \bar{\omega}) = \frac{\tan \bar{\omega}^1 - \tan \bar{\omega}}{1 + \tan \bar{\omega} \tan \bar{\omega}^1} = \frac{\frac{b^1}{a^1} - \frac{b}{a}}{1 + \frac{b b^1}{a a^1}} = \frac{a b^1 - b a^1}{a a^1 + b b^1}.$$

Multiplication by -1 means reversion, or rotation by $180^\circ =$ one-half period.

Multiplication by j means rotation by 90° , or retardation by one-quarter period.

Multiplication by $-j$ means rotation by -90° , or advance by one-quarter period.

Multiplication by $\cos \bar{\omega} + j \sin \bar{\omega}$ means rotation by angle $\bar{\omega}$.

II. CIRCUITS CONTAINING RESISTANCE, INDUCTANCE AND CAPACITY.

Having now established Ohm's law as the fundamental law of alternate currents, in its complex form :

$$E = I C,$$

where it represents not only the *intensity*, but the *phase* of the electric quantities also, we can by simple application of Ohm's law—in the same way as in continuous current circuits, keeping in mind, however, that E, C, I are complex quantities—dissolve and calculate any alternate current circuit, or network of circuits, containing resistance, inductance, or capacity in any combination, without meeting with greater difficulties than are met with in continuous current circuits. Indeed, the continuous current distribution appears as a particular case of the general problem, characterized by the disappearance of all imaginary terms.

As an instance, we shall apply this method to an *inductive*

circuit, shunted by a condenser, and fed through inductive mains, upon which a constant e. m. f. is impressed, as shown diagrammatically in Fig. 4.

Let r = resistance,

L = coefficient of self-induction, hence

$s = 2 \pi N L$ = inductance, and :

$I = r - j s$ = impedance of consumer circuit.

Let r_1 = resistance of condenser leads,

K = capacity, hence

$k = \frac{1}{2 \pi N K}$ = capacity inductance, and :

$I_1 = r_1 + j k$ = impedance of condenser circuit.

Let r_0 = resistance,

L_0 = coefficient of self-induction, hence

$s_0 = 2 \pi N L_0$ = inductance, and :

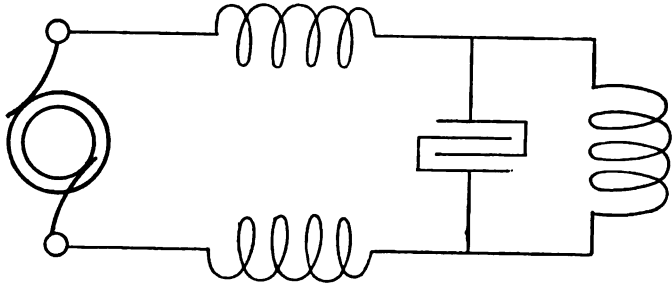

FIG. 4.

$I_0 = r - j s_0$ = impedance of the two main leads.

Let E_0 = e. m. f. impressed upon the circuit.

We have then, if, E = e. m. f. at ends of main leads, or at terminals of consumer and condenser circuit :

$$\text{Current in consumer circuit, } C = \frac{E}{I}$$

$$\text{Current in condenser circuit, } C_1 = \frac{E}{I_1}$$

$$\text{Hence, total current, } C_0 = C + C_1 = E \left(\frac{1}{I} + \frac{1}{I_1} \right)$$

$$\text{e. m. f. consumed in main leads } E^1 = C_0 I_0 = E \left(\frac{I_0}{I} + \frac{I_0}{I_1} \right)$$

$$\text{Hence, total e. m. f. } E_0 = E + E^1 = E \left\{ 1 + \frac{I_0}{I} + \frac{I_0}{I_1} \right\}$$

or, E. M. F. at end of main leads, $E = \frac{E_0 I I_1}{I_0 I + I_0 I_1 + I I_1}$

E. M. F. consumed by main leads, $E^1 = \frac{E_0 I_0 (I + I_1)}{I_0 I + I_0 I_1 + I I_1}$

Current in consumer circuit, $C = \frac{E}{I} = \frac{E_0 I_1}{I_0 I + I_0 I_1 + I I_1}$

Current in condenser circuit, $C_1 = \frac{E}{I_1} = \frac{E_0 I}{I_0 I + I_0 I_1 + I I_1}$

Total current, $C_0 = C + C_1 = \frac{E_0 (I + I_1)}{I_0 I + I_0 I_1 + I I_1}$

Substituting herein the values,

$$I_0 = r_0 - j s_0$$

$$I = r - j s$$

$$I_1 = r_1 + j k$$

and, $I_0 I + I_0 I_1 + I I_1 = a - j b,$

where, $a = r_0 r + r_0 r_1 + r r_1 - s_0 s + s_0 k + s k$

$$b = s_0 r + s_0 r_1 + s r_1 + s r_0 - r_0 k - r k$$

we get

$$E = \frac{E_0}{a^2 + b^2} \left\{ [a(rr_1 + sk) + b(r_1s - rk)] + j[b(rr_1 + sk) - a(r_1s - rk)] \right\}$$

$$C = \frac{E_0}{a^2 + b^2} \left\{ (r_1 a - k b) + j (r_1 b + k a) \right\}$$

$$C_1 = \frac{E_0}{a^2 + b^2} \left\{ (r a + s b) + j (r b - s a) \right\}$$

$$C_0 = \frac{E_0}{a^2 + b^2} \left\{ [(r + r_1) a + (s - k) b] + j[(r + r_1) b - (s - k) a] \right\}$$

As an instance, we may consider the case :

$$\begin{array}{lll} E_0 = 100 \text{ volts,} & & \\ \left. \begin{array}{l} r_0 = 1 \text{ ohm} \\ s_0 = 10 \text{ ohm} \\ I_0 = 1 - 10 j \end{array} \right\} & \left. \begin{array}{l} r = 2 \text{ ohm} \\ s = 10 \text{ ohm} \\ I = 2 - 10 j \end{array} \right\} & \left. \begin{array}{l} r_1 = 0 \\ k = 20 \text{ ohm} \\ I_1 = 20 j \end{array} \right\} \end{array}$$

hence $a = 302$
 $b = -30$

Substituting these values, we get,

$$E_0 = 100,$$

$$E = 68.0 (.98 + .17 j),$$

$$E^1 = 35.1 (.94 - .34 j),$$

$$C = 6.6 (.10 + .99 j),$$

$$\begin{aligned}C_1 &= 3.4 (.17 - .98 j), \\C_0 &= 3.4 (.37 + .93 j),\end{aligned}$$

where the complex quantities are represented in the form $c (\cos \bar{\omega} + j \sin \bar{\omega})$, so that the numerical value in front of the parenthesis gives the *effective intensity*, the parenthesis gives the *phase* of the alternate current or E. M. F.

This means: Of the 100 volts impressed, 35.1 volts are consumed by the leads, and 68.0 volts left at the end of the line.

The main current of 3.4 amperes divides into the consumer current of 6.6 amperes, and the condenser current of 3.4 amperes.

Increasing, however, the capacity K , that is reducing the capacity inductance to $k = 10$, or $I_1 = 10 j$, we get:

$$\begin{aligned}a &= 102, \\b &= 0.\end{aligned}$$

$$\begin{aligned}\text{Hence: } E_0 &= 100, \\E &= 100 (.98 + .20 j), \\E^1 &= 19.9 (.10 - .99 j), \\C &= 9.8 j, \\C_1 &= 10 (.20 - .98 j), \\C_0 &= 1.98.\end{aligned}$$

Here, though the leads consume 19.9 volts, still the full potential of 100 volts is left at their end.

1.98 amperes in the main line divide into two branch currents, of 9.8 and of 10 amperes. We have here one of the frequent cases, where one alternate current divides into two branches, so that either branch current is larger than the undivided or total current.

Increasing the capacity still further to $k = 5$, or $I_1 = 5 j$, gives:

$$\begin{aligned}a &= 2, \\b &= 15.\end{aligned}$$

$$\begin{aligned}\text{Hence: } E_0 &= 100, \\E &= 337 (.32 - .95 j), \\E^1 &= 318 (-.03 + j), \\C &= 33.0 (.99 + 13 j), \\C_1 &= 96.3 (1 + .06 j), \\C_0 &= 63.6 (1 + .03 j),\end{aligned}$$

That means, in the leads self-induction consumes an E. M. F. of 318 volts, and still 337 volts exist at the end of the line, giving

a rise of potential in the leads of 237 volts, due to the combined effect of self-induction and capacity.

The main current of 63.6 amperes divides into the two branch currents of 33.0 and 96.3 amperes.

The current which passes over the line is far larger than the current which in the absence of capacity would be permitted by the dead resistance of the line. While in this case 63.6 amperes flow over the line, a continuous E. M. F. of 100 volts would send

only $\frac{E_0}{r_0 + r} = 33.3$ amperes over the line; and with an alternating E. M. F., but without capacity the current would be limited to 4.95 amperes only, since in this case:

$$C_0 = \frac{E_0}{(r_0 + r) - j(s_0 + s)} = \frac{100}{3 - 20j} = 4.95 (.15 + .99j).$$

Even by short-circuiting the line, we get only:

$$C_0 = \frac{E_0}{r_0 - j s_0} = \frac{100}{1 - 10j} = 10 (.1 + .99j),$$

or 10 amperes over the line.

Hence we have in this arrangement of a condenser shunted to the inductive circuit and fed by inductive mains, the curious result that a short-circuit at the terminals of the consumer circuit reduces the line current to about one-sixth.

As a further instance, we may consider the problem:

“What is the maximum power which can be transmitted over an inductive line into a non-inductive resistance, as lights, and how far can this output be increased by the use of shunted capacity.”

Let, $r_0 =$ resistance,
 $s_0 =$ inductance,

hence, $I_0 = r_0 - j s_0 =$ impedance of the line.

Let $r =$ resistance of the consumer circuit, which is shunted by the capacity inductance k .

r and k are to be determined as to make the power in the receiving circuit: $C^2 r$, a maximum.

In a *continuous current circuit* the maximum output is reached, if $r = r_0$, or $E = \frac{E_0}{2}$, where E_0 is the E. M. F. at the beginning, E the E. M. F. at the end of the line, and $C = \frac{E_0}{2 r_0}$, hence:

$P = \frac{E_o^2}{4 r_o}$ the maximum output at efficiency 50 per cent.

Hence, if $E_o = 100$, $r_o = 1$, it is: $P = 2,500$ watts.

Very much less is the maximum output of an *alternate current circuit*. With an alternate e. m. f. E_o , but without the use of a condenser, the impedance of the whole circuit is:

$$I = r_o + r - j s_o,$$

$$\text{hence the current: } C = \frac{E_o}{I} = \frac{E_o (r_o + r - j s_o)}{(r_o + r)^2 + s_o^2}$$

$$= \frac{E_o}{\sqrt{(r_o + r)^2 + s_o^2}} \left\{ \frac{r_o + r}{\sqrt{(r_o + r)^2 + s_o^2}} + j \frac{s_o}{\sqrt{(r_o + r)^2 + s_o^2}} \right\}$$

the e. m. f. at end of line:

$$E = Cr = \frac{E_o r}{\sqrt{(r_o + r)^2 + s_o^2}} \left\{ \frac{r_o + r}{\sqrt{(r_o + r)^2 + s_o^2}} + j \frac{s_o}{\sqrt{(r_o + r)^2 + s_o^2}} \right\},$$

$$\text{hence the power: } P = EC = \frac{E_o^2 r}{(r_o + r)^2 + s_o^2}.$$

The condition of maximum output is,

$$\frac{\partial P}{\partial r} = 0$$

that is,

$$0 = (r + r_o)^2 + s_o^2 - 2r(r + r_o), \text{ or,}$$

$$r_2 = r_o^2 + s_o^2,$$

$$r = \sqrt{r_o^2 + s_o^2},$$

and the maximum output is,

$$P = \frac{E_o^2}{2 \{r_o + \sqrt{r_o^2 + s_o^2}\}}$$

$$\text{at the efficiency, } \frac{r}{r_o + r} = \frac{\sqrt{r_o^2 + s_o^2}}{r_o + \sqrt{r_o^2 + s_o^2}}$$

In the instance, $E_o = 100$, $r_o = 1$, $s_o = 10$ is:

$P = 453$ watts, against 2,500 watts with continuous currents.

If, however, we shunt the receiver circuit by capacity inductance k , we have,

$$\text{Leads, } I_o = r_o - j s_o,$$

$$\text{Consumer circuit, } I = r, s = 0,$$

$$\text{Condenser circuit, } I_1 = j k, r_1 = 0,$$

hence, by substituting in the equations derived in the first part of this chapter,

$$a = r_0 r + s_0 k$$

$$b = s_0 r - k(r_0 + r)$$

and,
$$C = \frac{E_0 k}{a^2 + b^2} (-b + j a),$$

or, substituting,

$$\tan \bar{\omega} = -\frac{a}{b}$$

and,
$$C = \frac{E_0 k}{\sqrt{a^2 + b^2}} (\cos \bar{\omega} + j \sin \bar{\omega})$$

$$E = C r = \frac{E_0 k r}{\sqrt{a^2 + b^2}} (\cos \bar{\omega} + j \sin \bar{\omega})$$

hence, power,

$$P = C E = \frac{E_0^2 k^2 r}{a^2 + b^2} = \frac{E_0^2 k^2 r}{(r_0 r + s_0 k)^2 + (s_0 r - k r_0 - k r)^2}$$

The condition of the maximum output P is,

$$\frac{\partial P}{\partial r} = 0, \quad \frac{\partial P}{\partial k} = 0$$

that is,

$$k^2 (r_0^2 + s_0^2) = r^2 (r_0^2 + [s_0 - k]^2) k s_0 = r_0^2 + s_0^2$$

hence,

$$k = \frac{r_0^2 + s_0^2}{s_0}$$

$$r = \frac{r_0^2 + s_0^2}{r_0}$$

substituting this in P , we get:

$$P = \frac{E_0^2}{4 r_0},$$

the same condition as for continuous current.

That means,

“No matter how large the self-induction of an alternating current circuit is, by a proper use of shunted capacity the output of the circuit can always be raised to the same as for continuous currents; that is, the effect of self-induction upon the output can entirely and completely be annihilated.”

III. THE ALTERNATE CURRENT TRANSFORMER.

A. General Remarks.

In the coils of an alternate current transformer, E. M. F. is induced by the alternations of the magnetism, which is produced by the combined magnetizing effect of primary and secondary current.

If, M = maximum magnetism,
 N = frequency (complete cycles per second),
 n = number of turns,

the *effective intensity* of the induced E. M. F. is,

$$E = \sqrt{2} \pi n N M 10^{-8}$$

$$= 4.44 n N M 10^{-8}$$

Hence, if E. M. F., frequency and number of turns are given, or chosen, this formula gives the *maximum magnetism*,

$$M = \frac{E 10^8}{\sqrt{2} \pi n N}$$

To produce the magnetism M of the transformer, a M. M. F. F is required, which is determined from the shape and the magnetic characteristic of the iron, in the usual manner.

At no load, or open secondary circuit, the M. M. F. F is furnished by the "exciting current," improperly called the "leakage current."

The energy of this current is the energy consumed by hysteresis and eddy-currents in the iron; its intensity represents the M. M. F.

This current is *not a sine-wave*, but is *distorted by hysteresis*. It reaches its maximum together with the maximum of magnetism, but passes through zero long before the magnetism.

This exciting current can be dissolved in two components: a *sine-wave* C_{∞} of equal intensity and equal power with the exciting current, and a *wattless complex higher harmonic*.

Practically this separation is made by the electro-dynamometer. Connecting ammeter, voltmeter and wattmeter into the primary of an alternate current transformer, at open secondary circuit the instrument readings give the current C_{∞} in intensity and phase, but suppress the higher harmonics.

In Fig. 5 such a wave is shown in rectangular coordinates. The sine-wave of magnetism is represented by the dotted curve M , the exciting current by the distorted curve c , which is separated into the sine-wave C_{∞} and the higher harmonic C .

As seen, the higher harmonic is small, even in a closed circuit transformer, compared with the exciting current C_{oo} , and since C_{oo} itself is only a few per cent. of the whole primary current, the higher harmonic can for all practical purposes be suppressed.

All tests made on transformers by electro-dynamometer methods suppress the higher harmonic anyway.

Representing the exciting current by a sine-wave C_{oo} of equal effective intensity and equal power with the distorted wave, the exciting current is advanced in phase against the magnetism by an angle α , which may be called the "*angle of hysteric advance of phase.*" This angle α is very small in all open circuit transformers, but may be as large as 40° to 50° in closed circuit transformers.

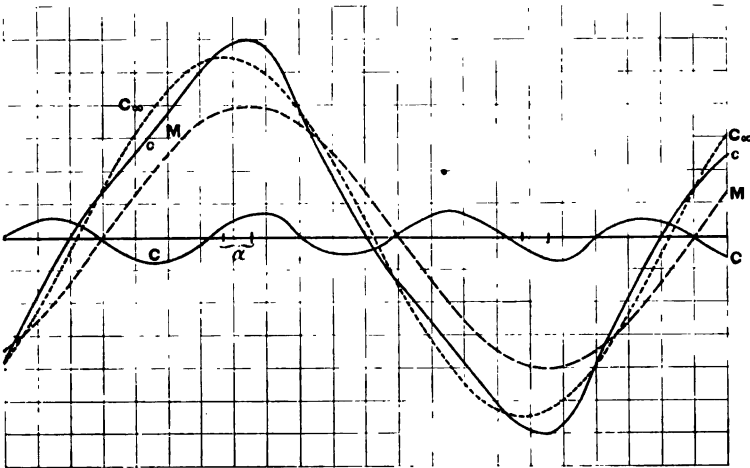

FIG. 5.

We can now in the usual manner dissolve the sine-wave of exciting current C_{oo} into its two rectangular components :

h , the "*hysteric energy current*" at right angles with the magnetism, hence in phase with the induced E. M. F., and, therefore *representing consumption of energy* ; and,

g , the "*magnetizing current*" in phase with the magnetism, hence at right angles with the induced E. M. F., and, therefore, *wattless.*

$h = C_{oo} \sin \alpha$, and can be calculated from the loss of energy by hysteresis (and eddies), for it is :

$$h = \frac{\text{energy consumed by hysteresis}}{\text{primary E. M. F.}}$$

And since C_{oo} can be calculated from shape and characteristic of the iron, the angle of hysteretic advance of phase a is given by:

$$\sin a = \frac{h}{C_{oo}}$$

The magnetizing current $g = C_{oo} \cos a$ does not consume energy (except by resistance), and can be supplied by a condenser of suitable capacity shunted to the transformer.

Since in the closed circuit transformer h , which cannot be supplied by a condenser, is not much smaller than C_{oo} , there is no advantage in using a condenser on a closed circuit transformer. In an open circuit transformer, however, or transformer motor, C_{oo} is very much larger than h , and a condenser may be of advantage in reducing the exciting current from C_{oo} to h .

B.—The Closed Circuit Lighting Transformer.

The alternate current transformer with closed magnetic circuit, when feeding into a non-inductive resistance, as lights, can be characterized by four constants:

ρ = resistance loss as fraction of the total transformed power:

$$\rho = \frac{\text{resistance loss}}{\text{total power}} \text{ at full load.}$$

ϵ = hysteretic loss as fraction of the total transformed power:

$$\epsilon = \frac{\text{hysteretic loss}}{\text{total power}} \text{ at full load.}$$

σ = E. M. F. of self-induction as fraction of total E. M. F.:

$$\sigma = \frac{\text{self-induction}}{\text{total E. M. F.}} \text{ at full load.}$$

τ = magnetizing current as fraction of total current:

$$\tau = \frac{\text{magnetizing current}}{\text{total current}} \text{ at full load.}$$

Denoting

In primary:

In secondary:

n_o	and	n_1	= number of turns.
r_o	"	r_1	= resistances.
C_o	"	C_1	= currents.
E_o	"	E_1	= induced E. M. F.'s.
E	"	E_t	= E. M. F.'s at terminals.
C_o^1	"	C_1^1	= currents at full load.

we have then:

$$\rho = \frac{C_1^1 r_1}{E_1} + \frac{C_o^1 r_o}{E_o},$$

$$\sigma = \frac{S}{M}, \text{ where}$$

S = magnetism leaking between primary and secondary.

M = magnetism surrounding both primary and secondary.

$$\epsilon = \frac{h}{C_o^1},$$

$$\tau = \frac{g}{C_o^1}.$$

Hence at the fraction ϑ of full load.

$$\vartheta = \frac{C_1}{C_1^1}$$

choosing the induced e. m. f. as the real axis of coordinates, the magnetism as the imaginary axis of coordinates), we have,

Primary exciting current, $C_{oo} = h + j g$

Primary current corresponding to secondary current C_1 , $\left\{ \begin{array}{l} C = \frac{n_1}{n_o} C_1 \end{array} \right.$

hence, total primary current, $C_o = C + C_{oo} = \frac{n_1}{n_o} C_1 + h + j g$

and, ratio of currents, $\frac{C_o}{C_1} = \frac{n_1}{n_o} + \frac{h + j g}{C_1}$

Since, however,

$$C_{oo} = h + j g = C_o^1 (\epsilon + j \tau) = \frac{n_1}{n_o} C_1^1 (\epsilon + j \tau) = \frac{n_1}{n_o} C_1 \frac{\epsilon + j \tau}{\vartheta},$$

we have, substituted,

Ratio of Currents.

$$\frac{C_o}{C_1} = \frac{n_1}{n_o} \left\{ 1 + \frac{\epsilon}{\vartheta} + j \frac{\tau}{\vartheta} \right\}$$

$$= \frac{n_1}{n_o} \sqrt{\left(1 + \frac{\epsilon}{\vartheta}\right)^2 + \left(\frac{\tau}{\vartheta}\right)^2} \text{ or, for medium and large load,}$$

$$= \frac{n_1}{n_o} \left\{ 1 + \frac{\epsilon}{\vartheta} + \frac{\tau^2}{2\vartheta^2} \right\}$$

The e. m. f. at the secondary terminals is,

$$E_t = E_1 - C_1 r_1 = E_1 \left\{ 1 - \rho \frac{\vartheta}{2} \right\}$$

at the primary terminals,

$$E = E_o + C_o (r_o - j s_o) = E_o \left\{ 1 + \rho \frac{\vartheta}{2} - j \sigma \vartheta \right\}$$

hence, since
$$E_o = \frac{\delta_o}{n_1} E_1,$$

Ratio of E. M. F.'s at terminals.

$$\begin{aligned} \frac{E}{E_t} &= \frac{n_o}{n_1} \left\{ 1 + \rho \vartheta - j \sigma \vartheta \right\} \\ &= \frac{n_o}{n_1} \left\{ 1 + \rho \vartheta + \frac{\sigma_2 \vartheta^2}{2} \right\} \end{aligned}$$

Difference of phase $\tilde{\omega}$ between E. M. F. at primary terminals and primary currents.

Since we have seen, that multiplying a complex quantity by $(\cos \tilde{\omega} + j \sin \tilde{\omega})$, means rotating its vector by angle $\tilde{\omega}$, the difference of phase between primary current and E. M. F., $\tilde{\omega}$ is, given by,

$$C_o = a (\cos \tilde{\omega} + j \sin \tilde{\omega}) E$$

or,
$$a (\cos \tilde{\omega} + j \sin \tilde{\omega}) = \frac{C_o}{E}$$

where $\tilde{\omega}$ is the difference of phase, and a a constant.

Since in the present case the secondary current is in phase with the secondary E. M. F., it is, $b = \frac{E_t}{C_1}$

combining this with the foregoing, we have,

$$\begin{aligned} a b (\cos \tilde{\omega} + j \sin \tilde{\omega}) &= \frac{C_o}{C_1} \frac{E_t}{E} \\ &= \left(\frac{n_1}{n_o} \right)^2 \frac{1 + \frac{\epsilon}{\vartheta} + j \frac{\tau}{\vartheta}}{1 + \rho \vartheta - j \sigma \vartheta} \\ &= \left(\frac{n_1}{n_o} \right)^2 \left\{ 1 - \rho \vartheta + \frac{\epsilon}{\vartheta} + j \sigma \vartheta + j \frac{\tau}{\vartheta} \right\} \end{aligned}$$

hence,

$$\begin{aligned} a b \cos \tilde{\omega} &= \left(\frac{n_1}{n_o} \right)^2 \left(1 - \rho \vartheta + \frac{\epsilon}{\vartheta} \right) = \left(\frac{n_1}{n_o} \right)^2 \\ a b \sin \tilde{\omega} &= \left(\frac{n_1}{n_o} \right)^2 \left(\sigma \vartheta + \frac{\tau}{\vartheta} \right) \end{aligned}$$

and,

Difference of phase between primary current and E. M. F. at terminals.

$$\tan \omega = \sigma \vartheta + \frac{\tau}{\vartheta}$$

hence :

“ With varying load ϑ , the difference of phase $\tilde{\omega}$ or the lag, first decreases, reaches a minimum at $\sigma \vartheta = \frac{\tau}{\vartheta}$ or $\vartheta = \sqrt{\frac{\tau}{\sigma}}$, and afterwards increases again.”

At light loads it is mainly the magnetizing current τ , at large load the self-induction σ , which determine the lag.

The formula, $\tan \tilde{\omega} = \sigma \vartheta + \frac{\tau}{\vartheta}$ is only an approximation, and ceases to hold for any light load, where we have to use the complete expression.

$$\tan \omega = \frac{\sigma \vartheta + \frac{\tau}{\vartheta}}{1 - \rho_1 \vartheta + \frac{\varepsilon}{\vartheta}}$$

The efficiency is, $1 - \left(\rho \vartheta + \frac{\varepsilon}{\vartheta} \right)$, and the

Loss coefficient, $\rho \vartheta + \frac{\varepsilon}{\vartheta}$

hence a minimum at, $\vartheta = \sqrt{\frac{\varepsilon}{\rho}}$, the point of maximum efficiency.

Let, as an instance, be :

$$\begin{array}{lll} \frac{n_o}{n_1} = 10 & \rho = .02 & \varepsilon = .03 \\ & \sigma = .06 & \tau = .08 \end{array}$$

hence,

at full load, $\vartheta = 1$,

$$\frac{C_o}{C_1} = .1 (1 + .03 + .0032) = .1033$$

$$\frac{E_o}{E_i} = 10 (1 + .02 + .0018) = 10.22$$

$$\tan \omega = .06 + .08 = .14, \text{ or, } \omega = 8^\circ,$$

energy factor, $\cos \omega = .99$

at 100% overload, $\vartheta = 2$,

$$\frac{C_o}{C_1} = .1 (1 + .015 + .0008) = .1016$$

$$\frac{E_o}{E_i} = 10 (1 + .04 + .0072) = 10.47$$

$$\tan \omega = .12 + .04 = .16, \text{ or, } \omega = 9^\circ,$$

$$\text{energy factor, } \cos \omega = .99$$

at one-half load :

$$\vartheta = .5 : \frac{C_o}{C_1} = .1 (1 + .06 + .0128) = .1073.$$

$$\frac{E_o}{E_t} = 10 (1 + .01 + .0005) = 10.11.$$

$$\tan \tilde{\omega} = .03 + .16 = .19, \text{ or } \tilde{\omega} = 11^\circ, \text{ energy factor : } \cos \tilde{\omega} = .98.$$

at one-tenth load :

$$\frac{C_o}{C_1} = 1 (1 + .3 + .32) = .162.$$

or more exactly,

$$= .1 \sqrt{(1 + .3)^2 + .8^2} = .153.$$

$$\frac{E_o}{E_t} = 10 (1 + .002 + .0000) = 10.02.$$

$$\tan \tilde{\omega} = .006 + .8 = .806.$$

or more exactly,

$$= \frac{.006 + .8}{1 - .002 + .3} = .62, \text{ or } \tilde{\omega} = 32^\circ, \text{ energy factor : } \cos \tilde{\omega} = .85,$$

at open secondary :

$$\tan \tilde{\omega} = \frac{.08}{.03} = 2.67, \text{ or } \tilde{\omega} = 70^\circ, \text{ energy factor : } \cos \tilde{\omega} = .34,$$

the minimum lag takes place at :

$$\vartheta = \sqrt{\frac{.08}{.06}} = 1.155,$$

or $15\frac{1}{2}$ per cent. overload, and is :

$$\tan \tilde{\omega} = .0693 + .0693 = .1386, \text{ or } \tilde{\omega} = 7.9^\circ, \text{ energy factor : } \cos \tilde{\omega} = .99,$$

the efficiency is a maximum at :

$$\vartheta = \sqrt{\frac{.03}{.02}} = 1.225.$$

or $22\frac{1}{2}$ per cent. overload, and is :

$$1 - .0245 - .0245 = .951, \text{ or } 95.1 \text{ per cent.}$$

C.—General Equations of Alternate Current Transformer.

The foregoing considerations will apply strictly only to the closed circuit transformer, where ρ , σ^2 , ϵ , τ^2 are so small that their

products and higher powers may be neglected when feeding into a non-inductive resistance.

The open circuit transformer, and in general the transformer feeding into an inductive circuit—in which case σ and τ become of greatly increased importance—requires a fuller consideration.

Let :

n_0 and n_1 = number of turns,

r_0 “ r_1 = resistance,

$s_0 = 2\pi N L_0$ and $s_1 = 2\pi N L_1$ = self-inductances, hence :

$I_0 = r_0 - j s_0$ and $I_1 = r_1 - j s_1$ = impedances of the two transformer coils.

The secondary terminals may be connected to a circuit of resistance R and inductance S , hence of impedance $I = R - j S$.

Then we have :

Magnetism : $j M$.

Secondary induced E. M. F. : $E_1 = \sqrt{2} \pi n_1 N M 10^{-8}$.

Primary induced E. M. F. : $E_0 = \sqrt{2} \pi n_0 N M 10^{-8} \frac{n_0}{n_1} E_1$.

Secondary current : $C_1 = \frac{E_1}{I + I_1} = \frac{E_1}{(R + r_1) - j(S + s_1)}$

or : $C_1 = a + j b$,

where :

$$a = \frac{E_1 (R + r_1)}{(R + r_1)^2 + (S + s_1)^2}, \quad b = \frac{E_1 (S + s_1)}{(R + r_1)^2 + (S + s_1)^2}.$$

Primary current corresponding hereto :

$$C = \frac{n_1}{n_0} C_1 = \frac{n_1}{n_0} a + j \frac{n_1}{n_0} b.$$

Primary exciting current :

$$C_{00} = h + j g,$$

hence, total primary current :

$$C_0 = C + C_{00} = \left(\frac{n_1}{n_0} a + h\right) + j \left(\frac{n_1}{n_0} b + g\right)$$

or : $C_0 = c + j d$,

where :

$$c = \frac{\frac{n_1}{n_0} E_1 (R + r_1)}{(R + r_1)^2 + (S + s_1)^2} + h, \quad d = \frac{\frac{n_1}{n_0} E_1 (S + s_1)}{(R + r_1)^2 + (S + s_1)^2} + g,$$

herefrom we get :

$P = \frac{E_0^2}{4 r_0}$ the maximum output at efficiency 50 per cent.

Hence, if $E_0 = 100$, $r_0 = 1$, it is: $P = 2,500$ watts.

Very much less is the maximum output of an *alternate current circuit*. With an alternate E. M. F. E_0 , but without the use of a condenser, the impedance of the whole circuit is:

$$I = r_0 + r - j s_0,$$

hence the current: $C = \frac{E_0}{I} = \frac{E_0 (r_0 + r - j s_0)}{(r_0 + r)^2 + s_0^2}$

$$= \frac{E_0}{\sqrt{(r_0 + r)^2 + s_0^2}} \left\{ \frac{r_0 + r}{\sqrt{(r_0 + r)^2 + s_0^2}} + j \frac{s_0}{\sqrt{(r_0 + r)^2 + s_0^2}} \right\}$$

the E. M. F. at end of line:

$$E = Cr = \frac{E_0 r}{\sqrt{(r_0 + r)^2 + s_0^2}} \left\{ \frac{r_0 + r}{\sqrt{(r_0 + r)^2 + s_0^2}} + j \frac{s_0}{\sqrt{(r_0 + r)^2 + s_0^2}} \right\},$$

hence the power: $P = EC = \frac{E_0^2 r}{(r_0 + r)^2 + s_0^2}$.

The condition of maximum output is,

$$\frac{\partial P}{\partial r} = 0$$

that is,

$$0 = (r + r_0)^2 + s_0^2 - 2r(r + r_0), \text{ or,}$$

$$r_2 = r_0^2 + s_0^2,$$

$$r = \sqrt{r_0^2 + s_0^2},$$

and the maximum output is,

$$P = \frac{E_0^2}{2 \{r_0 + \sqrt{r_0^2 + s_0^2}\}}$$

at the efficiency, $\frac{r}{r_0 + r} = \frac{\sqrt{r_0^2 + s_0^2}}{r_0 + \sqrt{r_0^2 + s_0^2}}$

In the instance, $E_0 = 100$, $r_0 = 1$, $s_0 = 10$ is:

$P = 453$ watts, against 2,500 watts with continuous currents.

If, however, we shunt the receiver circuit by capacity inductance k , we have,

Leads, $I_0 = r_0 - j s_0,$

Consumer circuit, $I = r, s = 0,$

Condenser circuit, $I_1 = j k, r_1 = 0,$

hence, by substituting in the equations derived in the first part of this chapter,

$$a = r_0 r + s_0 k$$

$$b = s_0 r - k(r_0 + r)$$

and,
$$C = \frac{E_0 k}{a^2 + b^2} (-b + j a),$$

or, substituting,

$$\tan \bar{\omega} = -\frac{a}{b}$$

and,
$$C = \frac{E_0 k}{\sqrt{a^2 + b^2}} (\cos \bar{\omega} + j \sin \bar{\omega})$$

$$E = C r = \frac{E_0 k r}{\sqrt{a^2 + b^2}} (\cos \bar{\omega} + j \sin \bar{\omega})$$

hence, power,

$$P = C E = \frac{E_0^2 k^2 r}{a^2 + b^2} = \frac{E_0^2 k^2 r}{(r_0 r + s_0 k)^2 + (s_0 r - k r_0 - k r)^2}$$

The condition of the maximum output P is,

$$\frac{\partial P}{\partial r} = 0, \quad \frac{\partial P}{\partial k} = 0$$

that is,

$$k^2 (r_0^2 + s_0^2) = r^2 (r_0^2 + [s_0 - k]^2) k s_0 = r_0^2 + s_0^2$$

hence,

$$k = \frac{r_0^2 + s_0^2}{s_0}$$

$$r = \frac{r_0^2 + s_0^2}{r_0}$$

substituting this in P , we get:

$$P = \frac{E_0^2}{4 r_0},$$

the same condition as for continuous current.

That means,

“No matter how large the self-induction of an alternating current circuit is, by a proper use of shunted capacity the output of the circuit can always be raised to the same as for continuous currents; that is, the effect of self-induction upon the output can entirely and completely be annihilated.”

F.'s consumed by resistance and inductance will, therefore, change also from point to point, being dependent upon the current.

In considering the effect of capacity, it is not permissible, however, to neglect the inductance, since in overhead lines the inductance is usually at least of the same magnitude as the condenser effect, and is not negligible in concentric cables even. In the latter, however, and to a lesser extent everywhere else, still other factors have to be considered.

The line consumes not only *currents in quadrature* with the E. M. F., but also *currents in phase* with the E. M. F.

Since no insulator has an infinite resistance, and at higher potentials not only *leakage*, but even direct *escape of electricity* into the air takes place by "silent discharge," we have to recognize the existence of a current approximately proportional, and in phase with the E. M. F. of the line. This current represents consumption of energy, and is therefore analogous to the E. M. F. consumed by resistance, while the condenser current, and the E. M. F. of inductance are wattless.

Furthermore, the alternate current passing over the line induces in all neighboring conductors secondary currents, which react upon the primary current and thereby introduce E. M. F.'s of *mutual inductance* into the primary circuit.

Mutual inductance is neither in phase nor in quadrature with the current, and can, therefore, be dissolved into an *energy component* of mutual inductance—which acts like an increase of resistance—in phase with the current, and a *wattless component*, in quadrature with the current—which decreases the self-inductance.

The mutual inductance is by no means negligible, as for instance, its disturbing influence in telephone circuits shows.

The alternate potential of the line induces by *electrostatic influence* electric charges in neighboring conductors outside of the circuit, which retain corresponding opposite charges in the line wires. This electrostatic influence requires the expenditure of a current, proportional to the E. M. F., and consisting of an *energy component*, in phase with the E. M. F., and a *wattless component*, in quadrature thereto.

The alternate electro-magnetic field of force, set up by the line current, causes in some materials a loss of energy by *electro-magnetic hysteresis*, requiring the expenditure of an E. M. F. in phase with the current, which acts like an increase of resis-

tance. The wattless component of this E. M. F. disappears under "inductance," or rather we must say, that the *hysteretic* E. M. F. is the *energy component of inductance*. This magnetic hysteresis loss may take place in the conductor proper, if iron wires are used, and will then be very serious at high frequencies, as with telephone currents, or it may take place in the iron armor of the cable, etc.

The effect of the "*eddy currents*" is referred to already under "mutual inductance," whose energy component it is.

The alternating electrostatic field of force, expends energy in dielectrics by what I called "*dielectric hysteresis*." In concentric cables, where the electrostatic gradient in the dielectric is comparatively large, the dielectric hysteresis may at high potentials even consume more energy than the ohmic resistance.

The dielectric hysteresis appears in the circuit as consumption of a current, whose component in phase with the E. M. F. is the "*dielectric energy current*"—the component in quadrature with the E. M. F. disappears in the "*condenser current*," whose energy component the dielectric energy current is.

Besides this, there is the increase of ohmic resistance due to *unequal distribution of current*, which, however, is practically never large enough to be noticeable.

Hence we have the phenomena:

Resistance—consumes E. M. F. in phase with current.

Self-inductance, and its energy component *electro-magnetic hysteresis*.

Mutual inductance, and its energy component *eddy currents*.

Leakage—consumes current in phase with E. M. F.

Capacity, and its energy component *dielectric hysteresis*.

Influence.

This gives, as the most general case, per unit length of line; E. M. F.'s consumed in phase with the current C , and $= r C$, representing consumption of energy and due to:

Resistance, and its increase by unequal current distribution.

Energy component of *self-induction*, or *electro-magnetic hysteresis*.

Energy component of *mutual inductance*, or *induced currents*.

E. M. F.'s consumed in quadrature with the current C , and $= s C$, being wattless, and due to:

Self-inductance.

Mutual inductance.

Currents consumed in phase with the E. M. F. E and $= \vartheta E$,
representing consumption of energy, and due to :

Leakage through the insulation, including silent discharge.

Energy component of capacity, or dielectric hysteresis.

Energy component of electrostatic influence.

Currents consumed in quadrature with the E. M. F. E and $= x E$,
being wattless, and due to :

Capacity.

Electrostatic influence.

Hence we get four constants :

$r, s, \vartheta, x.$

representing the coefficient, per unit length of line, of :

E. M. F.'s consumed in phase with current, $r.$

E. M. F.'s consumed in quadrature with current, $s.$

Currents consumed in phase with E. M. F., $\vartheta.$

Currents consumed in quadrature with E. M. F., $x.$

This line we may assume now as feeding into a *receiver circuit of any description*, and determine current and E. M. F. at any point of the circuit :

That is :

E. M. F. and current (differing in phase by any desired angle) may be given at the terminals of the receiver circuit. To be determined is the E. M. F. and the current at any point of the line, for instance at the generator terminals.

Or :

Impedance $I = R - j S$ of receiver circuit, and E. M. F. E_0 at generator terminals are given. Current and E. M. F. at any point of circuit are to be determined, etc.

The cases, which are usually and solely treated :

1. Current $= 0$ at end of line, that is open circuit.

2. E. M. F. $= 0$ at end of line, that is line grounded, and

3. Line of infinite length

are evidently of little practical interest, but of importance is only the case of a line feeding into an inductive or non-inductive receiver circuit.

Of the four line constants, r, s, ϑ, x , usually :

r is mainly the resistance, per unit length of line.

s is mainly $= 2 \pi N L$, where $L =$ coefficient of self-induction, per unit length of line.

ϑ is mainly $= \frac{1}{i}$, where i the insulation resistance, per unit length of line.

x is mainly $= 2 \pi N K$, where K = the capacity, per unit length of line.

Counting now the distance x from a point O of the line, which has the e. m. f.,

$$E_1 = e_1 + j e_1'$$

the current,

$$C_1 = c_1 + j c_1'$$

and counting x positive in the direction of rising energy,

counting x negative in the direction of decreasing energy,

we have at any point x , in the line differential $d x$:

$$\text{Leakage current, } E \vartheta d x$$

$$\text{Capacity current, } -j E x d x$$

hence, total current consumed by $d x$:

$$d C = E (\vartheta - j x) d x, \text{ or:}$$

$$\frac{d C}{d x} = E (\vartheta - j x) \quad (1.)$$

e. m. f. consumed by resistance, $C r d x$

e. m. f. consumed by inductance, $-j C s d x$

hence, total e. m. f. consumed by $d x$:

$$d E = C (r - j s) d x, \text{ or:}$$

$$\frac{d E}{d x} = C (r j s) \quad (2.)$$

These *Fundamental Differential Equations* (1.) and (2.) are symmetrical in C and E .

Differentiating these equations:

$$\left. \begin{aligned} \frac{d^2 C}{d x^2} &= \frac{d E}{d x} (\vartheta - j x) \\ \frac{d^2 E}{d x^2} &= \frac{d C}{d x} (r - j s) \end{aligned} \right\} \quad (3.)$$

and substituting (3.) in (1.) and (2.), gives:

$$\frac{d^2 E}{d x^2} = E (\vartheta - j x) (r - j s) \quad (4.)$$

$$\frac{d^2 C}{d x^2} = C (\vartheta - j x) (r - j s) \quad (5.)$$

The Differential Equation of C and of E.

These Differential Equations are identical, and consequently C and E are functions differing by their limiting conditions only.

These equations (4.) and (5.) are of the form :

$$\frac{d^2 w}{dx^2} = w (\vartheta - j x) (r - j s) \quad (6.)$$

and are integrated by :

$$w = a \varepsilon^{vx}$$

where ε is the base of natural logarithms.

For, differentiating this, we get :

$$\frac{d^2 w}{dx^2} = v^2 a \varepsilon^{vx} = v^2 w$$

hence :

$$v^2 = (\vartheta - j x) (r - j s) \quad (7.)$$

or :

$$v = \pm \sqrt{(\vartheta - j x) (r - j s)}$$

hence, the *complete integral* is ;

$$w = a \varepsilon^{+vx} + b \varepsilon^{-vx} \quad (8.)$$

where a and b are the two constants of integration.

Substituting :

$$v = a - j \beta \quad (9.)$$

in (7.), we have :

$$\left. \begin{aligned} (a - j \beta)^2 &= (\vartheta - j x) (r - j s), \text{ or :} \\ a^2 - \beta^2 &= \vartheta r - x s \\ 2 a \beta &= \vartheta s + x r \end{aligned} \right\} \quad (10.)$$

herefrom : $a^2 + \beta^2 = \sqrt{(\vartheta^2 + x^2) (r^2 + s^2)}$

$$\text{and : } \left. \begin{aligned} a &= \sqrt{\frac{1}{2} \{ \sqrt{(\vartheta^2 + x^2) (r^2 + s^2)} + (\vartheta r - x s) \}} \\ \beta &= \sqrt{\frac{1}{2} \{ \sqrt{(\vartheta^2 + x^2) (r^2 + s^2)} - (\vartheta r - x s) \}} \end{aligned} \right\} \quad (11.)$$

substituting (9.) in (8.):

$$\begin{aligned} w &= a \varepsilon^{(a-j\beta)x} + b \varepsilon^{-(a-j\beta)x} \\ &= a \varepsilon^{ax} (\cos \beta x - j \sin \beta x) + b \varepsilon^{-ax} (\cos \beta x + j \sin \beta x) \end{aligned}$$

$$w = (a \varepsilon^{ax} + b \varepsilon^{-ax}) \cos \beta x - j (a \varepsilon^{ax} - b \varepsilon^{-ax}) \sin \beta x \quad (12.)$$

the general solution of differential equations (4.) and (5.)

Differentiating (8.) gives :

$$\frac{dw}{dx} = v (a \varepsilon^{vx} - b \varepsilon^{-vx})$$

hence, substituting (9.):

$$\frac{dw}{dx} = (a - j\beta) \{ (a\epsilon^{ax} - b\epsilon^{-ax}) \cos \beta x - j(a\epsilon^{ax} + b\epsilon^{-ax}) \sin \beta x \} \quad (13.)$$

substituting now C for w , and substituting (13.) in (1.), and writing:

$$\begin{aligned} (a - j\beta) a &= A \\ (a - j\beta) b &= B \end{aligned}$$

we get the

General Integral Equations of the Problem.

$$\left. \begin{aligned} C &= \frac{1}{a - j\beta} \{ (A\epsilon^{ax} + B\epsilon^{-ax}) \cos \beta x - j(A\epsilon^{ax} - B\epsilon^{-ax}) \sin \beta x \} \\ E &= \frac{1}{\beta - jx} \{ (A\epsilon^{ax} - B\epsilon^{-ax}) \cos \beta x - j(A\epsilon^{ax} + B\epsilon^{-ax}) \sin \beta x \} \end{aligned} \right\} \quad (14.)$$

where A and B are the Constants of Integration.

If: $C_1 = c_1 + j c_1'$ is the current,

$$E_1 = e_1 + j e_1' \text{ is the E. M. F.} \quad (15.)$$

at the point: $x = 0$,

We get, substituting (15.) in (14.)

$$\left. \begin{aligned} 2A &= \{ (ac_1 + \beta c_1') + (\partial e_1 + x e_1') \} + j \{ (ac_1' - \beta c_1) + (\partial e_1' - x e_1) \} \\ 2B &= \{ (ac_1 + \beta c_1') - (\partial e_1 + x e_1') \} + j \{ (ac_1' - \beta c_1) - (\partial e_1' - x e_1) \} \end{aligned} \right\} \quad (16.)$$

If: $I = R - j S$ is the impedance of the receiver circuit, and

$$E_0 = e_0 + j e_0' \quad (17.)$$

is the E. M. F. at the dynamo terminals, and

l = length of line, we get at: $x = 0$:

$$\begin{aligned} C &= \frac{A + B}{a - j\beta} \\ E &= \frac{A - B}{\beta - jx} \end{aligned}$$

hence:

$$\begin{aligned} I &= \frac{E}{C} = \frac{A - B}{A + B} \frac{a - j\beta}{\beta - jx} \text{ or:} \\ \frac{A - B}{A + B} &= I \frac{\beta - jx}{a - j\beta} \end{aligned} \quad (18.)$$

and at: $x = l$:

$$E_0 = \frac{1}{\beta - jx} \{ (A\epsilon^{al} - B\epsilon^{-al}) \cos \beta l - j(A\epsilon^{al} + B\epsilon^{-al}) \sin \beta l \} \quad (19.)$$

Equations (18.) and (19.) determine the constants A and B , which, substituted in (14.), give the final integral equations.

The length: $x_0 = \frac{2\pi}{\beta}$ is a complete wave length, that means, in the distance $x_0 = \frac{2\pi}{\beta}$ the phase of current and e. m. f. repeat, in half this distance they are just opposite. Hence the remarkable condition exists in a very long line, that at different points at the same time the currents flow in opposite directions, and the e. m. f.'s are opposite.

The *Difference of phase* between current and e. m. f. at any point of the line is determined by :

$$I(\cos \omega + j \sin \omega) = \frac{C}{E},$$

where I is a constant.

Hence, ω varies from point to point, oscillating around a medium position ω_∞ , which it approaches at infinity.

This difference of phase, towards which current and e. m. f. tend at infinity, is determined by :

$$I(\cos \omega_\infty + j \sin \omega_\infty) = \frac{C_\infty}{E_\infty}$$

or, substituting for C_∞ and E_∞ their values, since $\epsilon^{-ax} = O$, and $A \epsilon^{ax} (\cos \beta x - \sin \beta x)$ cancels :

$$\begin{aligned} I(\cos \omega_\infty + j \sin \omega_\infty) &= \frac{\vartheta - j x}{a - j \beta} \\ &= \frac{(\alpha \vartheta + \beta x) - j(\alpha x - \beta \vartheta)}{\alpha^2 + \beta^2} \\ \tan \omega_\infty &= \frac{\beta \vartheta - \alpha x}{\alpha \vartheta + \beta x} \end{aligned} \quad (20.)$$

This angle $\omega_\infty = O$, that is, current and e. m. f. come more and more in phase with each other, if: $\beta \vartheta - \alpha x = O$, that is :

$$\alpha \div \beta = \vartheta \div x, \text{ or:}$$

$$\frac{\alpha^2 - \beta^2}{2\alpha\beta} = \frac{\vartheta^2 - x^2}{2\vartheta x}$$

substituting (10.), gives: $\frac{\vartheta r - x s}{\vartheta s + x r} = \frac{\vartheta^2 - x^2}{2\vartheta x}$,

hence, expanded :

$$r \div s = \vartheta \div x. \tag{21.}$$

that is :

“The ratio of resistance to inductance equals the ratio of leakage to capacity.”

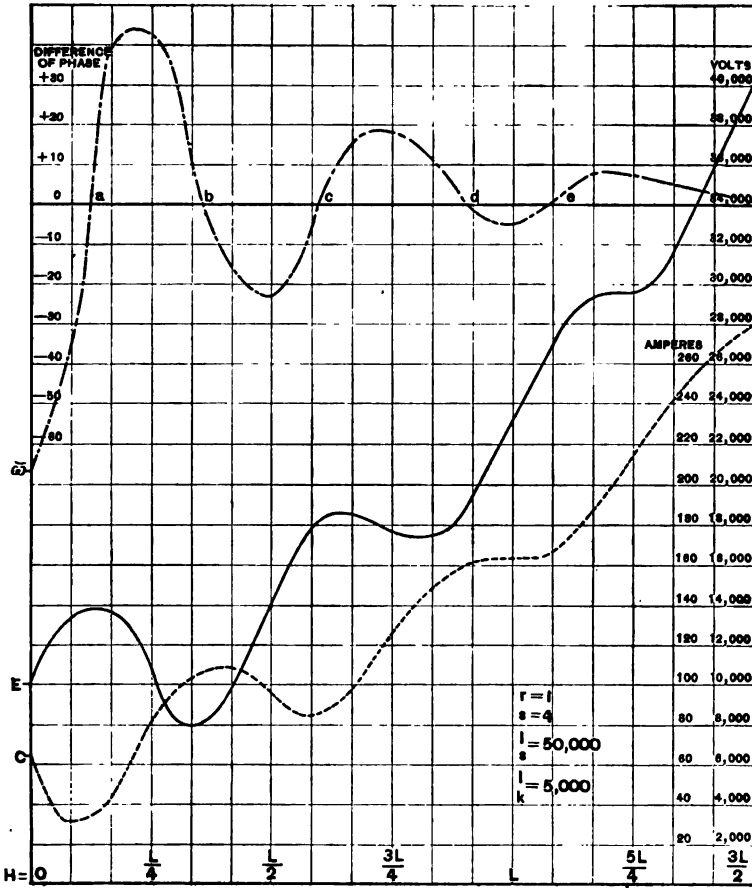

FIG. 6.

This angle $\omega \infty = 45^\circ$, that is, current and E. M. F. differ by one-eighth period, if: $\beta \vartheta - \alpha x = \alpha \vartheta + \beta x$, that is :

$$\frac{\alpha}{\beta} = \frac{\vartheta + x}{\vartheta - x}$$

or :

$$r \vartheta + s x = 0 \tag{22.}$$

that is:

"Two of the four line constants must be = 0, either δ and x or δ and α ."

As an instance, in Fig. 6 a line diagram is shown, with the distances from the receiver end as abscissæ. Figure 6 represents one and a half complete waves, and gives total effective current, total E. M. F., and difference of phase between both, as functions of the distance from receiver circuit, under the conditions:

E. M. F. at receiving end: 10,000 volts, hence: $E_1 = e_1 = 10,000$.

Current at receiving end: 65 amperes at .385 energy coefficient, that is:

$$C_1 = e_1 + j c_1^1 = 25 + 60 j.$$

Line constants per unit length:

$$r = 1 \quad \delta = 2 \times 10^{-5}$$

$$s = 4 \quad x = 20 \times 10^{-5}$$

hence:

$$\alpha = 4.95 \times 10^{-3}$$

$$\beta = 28.36 \times 10^{-3}$$

$$\alpha^2 + \beta^2 = .829 \times 10^{-3}$$

$$x_0 = L = \frac{2\pi}{\beta} = 221.5 = \text{length of line, corresponding to}$$

one complete period of wave propagation.

$$A = 1.012 - 1.206 j$$

$$B = .812 + .794 j$$

These values substituted give:

$$C = \left\{ \epsilon^{ax} (47.3 \cos \beta x + 27.4 \sin \beta x) - \epsilon^{-ax} (22.3 \cos \beta x + 32.6 \sin \beta x) \right\}$$

$$+ j \left\{ \epsilon^{ax} (27.4 \cos \beta x - 47.3 \sin \beta x) + \epsilon^{-ax} (32.6 \cos \beta x - 22.3 \sin \beta x) \right\}$$

$$E = \left\{ \epsilon^{ax} (6450 \cos \beta x + 4410 \sin \beta x) + \epsilon^{-ax} (3530 \cos \beta x - 4410 \sin \beta x) \right\}$$

$$+ j \left\{ \epsilon^{ax} (4410 \cos \beta x - 6450 \sin \beta x) - \epsilon^{-ax} (4410 \cos \beta x - 3530 \sin \beta x) \right\}$$

$$\tan \omega_{\infty} = \frac{\beta \delta - \alpha x}{\alpha \delta + \beta x} = -.072, \quad \omega_{\infty} = -4.2^\circ.$$

*Some Particular Cases.**A. Open Circuit at End of Line.*

$$x = 0. \quad C_1 = 0.$$

$$A = (\vartheta e_1 + x e_1') + j (\vartheta e_1' - x e_1) = -B$$

hence:

$$E = \frac{1}{\vartheta - jx} A \left\{ (\epsilon^{ax} + \epsilon^{-ax}) \cos \beta x - j (\epsilon^{ax} - \epsilon^{-ax}) \sin \beta x \right\}$$

$$C = \frac{1}{a - j\beta} A \left\{ (\epsilon^{ax} - \epsilon^{-ax}) \cos \beta x - j (\epsilon^{ax} + \epsilon^{-ax}) \sin \beta x \right\}$$

B. Line Grounded at End.

$$x = 0. \quad E_1 = 0.$$

$$A = (a c_1 + \beta c_1') + j (a c_1' - \beta c_1) = B,$$

hence:

$$E = \frac{1}{\vartheta - jx} A \left\{ (\epsilon^{ax} - \epsilon^{-ax}) \cos \beta x - j (\epsilon^{ax} + \epsilon^{-ax}) \sin \beta x \right\}$$

$$C = \frac{1}{a - j\beta} A \left\{ (\epsilon^{ax} + \epsilon^{-ax}) \cos \beta x - j (\epsilon^{ax} - \epsilon^{-ax}) \sin \beta x \right\}$$

C. Infinitely Long Conductors.

Replacing x by $-x$, that is, counting distance positive in the direction of decreasing energy, we have:

$$x = \infty: \quad C = 0, \quad E = 0:$$

hence: $B = 0$

$$\text{and: } E = \frac{1}{\vartheta - jx} A \epsilon^{-ax} (\cos \beta x + j \sin \beta x)$$

$$C = \frac{1}{a - j\beta} A \epsilon^{-ax} (\cos \beta x + j \sin \beta x)$$

revolving decay of the wave.

The *total impedance* of the infinite circuit is:

$$\begin{aligned} I &= \frac{E}{C} \\ &= \frac{a - j\beta}{\vartheta - jx} \\ &= \frac{(a\vartheta + \beta x) - j(\beta\vartheta - ax)}{\vartheta^2 + x^2} \end{aligned}$$

“The infinitely long conductor acts like an impedance

$I = \frac{a \vartheta + \beta x}{\vartheta^2 + x^2} - j \frac{\beta \vartheta - a x}{\vartheta^2 + x^2}$, that is, like a resistance

$R = \frac{a \vartheta + \beta x}{\vartheta^2 + x^2}$, combined with an inductance $S = \frac{\beta \vartheta - a x}{\vartheta^2 + x^2}$.

Herefrom we get the difference of phase between E. M. F. and current:

$$\tan \omega = \frac{S}{R} = \frac{\beta \vartheta - a x}{a \vartheta + \beta x}$$

which is constant at all points of the line:

If: $\vartheta = 0, s = 0$, we have: $a = \beta = \sqrt{\frac{x r}{2}}$, hence:

$$\tan \omega = 1, \text{ or: } \omega = 45^\circ.$$

that is, current and E. M. F. differ by one-eighth period.

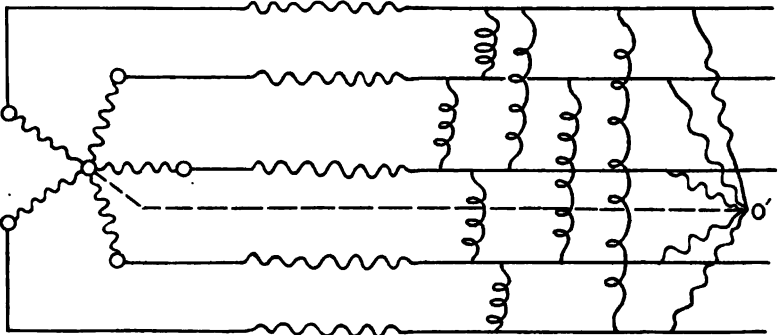

FIG. 7.

D. Generator Feeding into Closed Circuit:

Let $x = 0$ be the center of the cable. It is then:

$$C_x = C_{-x},$$

$$E_x = -E_{-x},$$

hence: $E = 0$ at $x = 0$,

that means, the equations are the same as in B., where the line is grounded at $s = 0$.

V. POLYPHASE SYSTEMS.

In polyphase systems, we have two ways of connecting the n circuits of an n -phase generator with each other and with the line.

1. The *star connection*, represented diagrammatically in Fig. 7, where the n -circuits, containing E. M. F.'s differing from each

other by $\frac{1}{n}$ of a period, are connected together at one end into a *neutral point* O —which may either be grounded or not—while the other ends of the circuit are connected to the line-wires, and:

2. The *ring connection*, represented by Fig. 8, where the n generator circuits are connected in closed circuit, and the n line wires connected to the points of contact of adjacent circuits.

Outside of the generator the two systems are identical.

The consumer circuits may now either be connected between any pairs or sets of line-wires, or between the wires and a neutral point O' , which may be grounded, or connected to the neutral point of the generator O .

1. Let now, in the *star connection* of generator, E be the e.

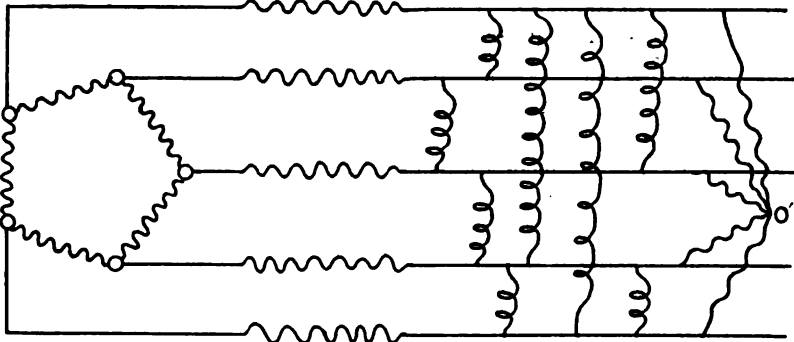

Fig. 8.

m. f. of one branch of the generator, and let 1, 2, . . . n be the generator circuits.

Since the e. m. f.'s of adjacent circuits differ by $\frac{1}{n}$ of a period, $= \frac{2\pi}{n}$, and rotation by $\frac{2\pi}{n}$ is represented algebraically by multiplication with:

$$\epsilon = \cos \frac{2\pi}{n} + j \sin \frac{2\pi}{n} = \sqrt[n]{1} \tag{1.}$$

The e. m. f. in any circuit i is:

$$E_i = \epsilon^i E \tag{2.}$$

Hence, if C_i is the current in circuit i , and I is the impedance per generator circuit, we have:

E. M. F. at terminal i of generator:

$$E'_i = E_i - C_i I = \epsilon^i E - C_i I \quad (3.)$$

And the E. M. F. at the end of a line of impedance I_i , connected to terminal i :

$$E''_i = E_i - C_i (I + I_i) = \epsilon^i E - C_i (I + I_i) \quad (4.)$$

Let now E_{ix} denote the difference of potential between any pair of terminals i and x ,

$$\text{where:} \quad E_{ix} = - E_{xi} \quad (5.)$$

we have:

E. M. F. of generator, acting between terminals i and x :

$$E_{ix} = (\epsilon_i - \epsilon_x) E \quad (6.)$$

Difference of potential between generator terminals i and x :

$$E'_{ix} = (\epsilon^i - \epsilon^x) E - I(C_i - C_x) \quad (7.)$$

Difference of potential between lines i and x :

$$E''_{ix} = (\epsilon^i - \epsilon^x) E - I(C_i - C_x) - (I_i C_i - I_x C_x) \quad (8.)$$

If now C_{ix} represents the current, which passes from line i to x (and which is determined by the impedance I_{ix} of the apparatus connected between i and x :

$$C_{ix} = \frac{E_{ix}}{I_{ix}}$$

and if C_{io} denotes the current passing from line i to neutral point O' , we have:

$$C_i = \sum_0^n C_{ix} \quad (9.)$$

Furthermore, if the neutral points O and O' are insulated.

$$\left. \begin{aligned} \sum_1^n C_i &= O \\ \sum_1^n C_{io} &= O \end{aligned} \right\} \quad (10.)$$

If, however, the neutral point O and O' are grounded, or connected together:

$$\sum_1^n C_i = \sum_1^n C_{io} \quad (11.)$$

2. In the case of the *ring connected* generator, the generator E. M. F.'s:

$$\epsilon^i E$$

Take the place of the E. M. F.'s

$$E_{i+1}$$

of the star connection, hence the E. M. F. between any pair of terminals i and x is:

$$\sum (E_i + E_{i+1} + \dots + E_x) = E \sum_i^n \epsilon^{\theta} \quad (12.)$$

All the other considerations remain essentially the same, so that:

“Any polyphase system of the E. M. F.'s:

$$E_i = \epsilon^i E, \quad i = 1, 2, \dots n, \quad \epsilon = \sqrt[n]{1} \quad (13.)$$

can be dissolved by Ohm's law:

$$E = C I \quad (14.)$$

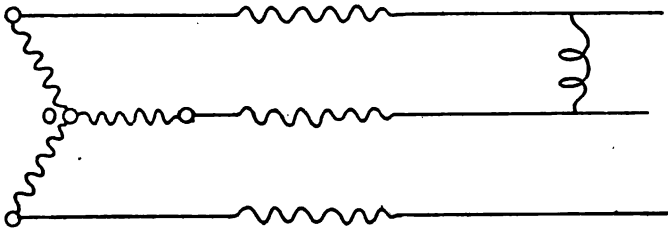

FIG. 9.

and Kirchhoff's laws:

$$\sum E = 0 \text{ in any closed circuit,} \quad (15.)$$

$$\sum C = 0 \text{ at any point of distribution.} \quad (16.)$$

It would carry me too far for the scope of this paper, to enter further into the general theory of the polyphase systems, and it may be sufficient therefore, to show in a particular instance, taken from the threephase system, what remarkable phenomena can be expected in polyphase systems.

Unbalanced Threephase System.

Let, in a threephase system, Fig. 9, with star connected generator,

$$E, \epsilon E, \epsilon^2 E$$

be the E. M. F.'s of the three generator branches, where:

$$\begin{aligned}\epsilon &= \sqrt[3]{1} = \frac{-1 + j\sqrt{3}}{2} \\ \epsilon^2 &= \frac{-1 - j\sqrt{3}}{2}\end{aligned}$$

Let I = impedance per generator branch,

I_1 = impedance per line,

and let one pair of lines be connected by an impedance I_2 .

We have then, if C = the current flowing in this loaded branch—the two other branches being unloaded, or open—that is, the system “unbalanced.”

$$\begin{array}{l} \text{E. M. F. in generator circuits:} \\ \quad E \\ \quad \epsilon E \\ \quad \epsilon^2 E \end{array} \left. \vphantom{\begin{array}{l} \text{E. M. F. in generator circuits:} \\ \quad E \\ \quad \epsilon E \\ \quad \epsilon^2 E \end{array}} \right\} (17.)$$

$$\begin{array}{l} \text{Potentials at generator terminals:} \\ \quad E - CI \\ \quad \epsilon E + CI \\ \quad \epsilon^2 E \end{array} \left. \vphantom{\begin{array}{l} \text{Potentials at generator terminals:} \\ \quad E - CI \\ \quad \epsilon E + CI \\ \quad \epsilon^2 E \end{array}} \right\} (18.)$$

$$\begin{array}{l} \text{Potentials at end of lines:} \\ \quad E - C(I + I_1) \\ \quad \epsilon E + C(I + I_1) \\ \quad \epsilon^2 E \end{array} \left. \vphantom{\begin{array}{l} \text{Potentials at end of lines:} \\ \quad E - C(I + I_1) \\ \quad \epsilon E + C(I + I_1) \\ \quad \epsilon^2 E \end{array}} \right\} (19.)$$

Hence, differences of potential at generator terminals:

$$\begin{array}{l} E(1 - \epsilon) - 2CI \quad \text{—loaded branch.} \\ \epsilon E(1 - \epsilon) + CI \\ \epsilon^2 E(1 - \epsilon) + CI \end{array} \left. \vphantom{\begin{array}{l} E(1 - \epsilon) - 2CI \\ \epsilon E(1 - \epsilon) + CI \\ \epsilon^2 E(1 - \epsilon) + CI \end{array}} \right\} \text{—unloaded branches.} \quad (20.)$$

Difference of potential at ends of line:

$$\begin{array}{l} E(1 - \epsilon) - 2C(I + I_1) \quad \text{—loaded branch.} \\ \epsilon E(1 - \epsilon) + C(I + I_1) \\ \epsilon^2 E(1 - \epsilon) + C(I + I_1) \end{array} \left. \vphantom{\begin{array}{l} E(1 - \epsilon) - 2C(I + I_1) \\ \epsilon E(1 - \epsilon) + C(I + I_1) \\ \epsilon^2 E(1 - \epsilon) + C(I + I_1) \end{array}} \right\} \text{—unloaded branches.} \quad (21.)$$

Hence, current in loaded branch:

$$C = \frac{E(1 - \epsilon) - 2C(I + I_1)}{I_2}$$

or, expanded:

$$C = \frac{E(1 - \epsilon)}{I_2 + 2(I + I_1)}, \text{ as was to be expected, since} \quad (22.)$$

$I_2 + 2(I + I_1)$ is the total impedance, $E(1 - \epsilon)$ the E. M. F. of this circuit.

Substituting (22.) in (20.) and (21.), we get:

Difference of potential at generator terminals:

$$\left. \begin{aligned} E(1 - \epsilon) \left(1 - \frac{2I}{I_2 + 2(I + I_1)} \right) & \text{—loaded branch.} \\ E(1 - \epsilon) \left(\epsilon + \frac{I}{I_2 + 2(I + I_1)} \right) & \\ E(1 - \epsilon) \left(\epsilon^2 + \frac{I}{I_1 + 2(I + I_1)} \right) & \end{aligned} \right\} \text{—unloaded branches.} \quad (23.)$$

Difference of potential at ends of line:

$$\left. \begin{aligned} E(1 - \epsilon) \left(1 - \frac{2(I + I_1)}{I_2 + 2(I + I_1)} \right) & \text{—loaded branch.} \\ E(1 - \epsilon) \left(\epsilon + \frac{I + I_1}{I_2 + 2(I + I_1)} \right) & \\ E(1 - \epsilon) \left(\epsilon^2 + \frac{I + I_1}{I_2 + 2(I + I_1)} \right) & \end{aligned} \right\} \text{—unloaded branches.} \quad (24.)$$

These are three different values. That means:

“Loading in a three phase system one branch only, the potentials of the two unloaded branches become unequal also.”

It is self evident, that this phenomenon of unbalancing does not take place in the three phase system only, but just as well in any other polyphase system, and that the amount of unbalancing depends upon the constants of the circuit, hence, can by a proper arrangement be reduced to almost nil, or can be exaggerated greatly by an improper choice of circuit constant.

As an instance, we may consider the numerical example:

Generator E. M. F. 100 volts between terminals, hence:

$$E(1 - \epsilon) = 100$$

Resistance per generator branch, .01 ohms.

Inductance per generator branch, .05 ohms.

Hence, impedance per generator branch, .01 — .05 *j*.

Case 1. Non-inductive line of .1 ohms.)

Non-inductive load of .1 ohms.)

Case 2. Non-inductive line of .1 ohms.)

Inductive load of — *j* ohms.)

Case 3. Inductive line of — .1 *j* ohms.)

Inductive load of — *j* ohms.)

Case 4. Inductive line of — .1 *j* ohms.)

Non-inductive load of .1 ohms.)

Substituting these values in equations (22.), (23.) and (24.) we get (writing all the quantities in the form, $c(\cos \omega + j \sin \omega)$):

1. Non-inductive line and non-inductive load; $I_1 = .1, I_2 = 1$:

$$C = 81.6(.99 + .08j)$$

$$\begin{array}{ll} E_1 = 98.0(.99 + .08j) & E'_1 = 81.6(.99 + .08j) \\ E_2 = 95.9(-.51 + .86j) & E'_2 = 92.6(-.44 + .90j) \\ E_3 = 102.9(-.47 - .88j) & E'_3 = 98.7(-.41 - .91j) \end{array}$$

2. Non-inductive line, inductive load: $I_1 = .1, I_2 = -j$:

$$C = 89.0(.20 + .98j)$$

$$\begin{array}{ll} E_1 = 90.9 & E'_1 = 89.1(.98 - .20j) \\ E_2 = 97.8(-.47 + .88j) & E'_2 = 104.9(-.42 + .92j) \\ E_3 = 97.8(-.47 - .88j) & E'_3 = 89.3(-.49 - .86j) \end{array}$$

3. Inductive line and inductive load: $I_1 = -.1j, I_2 = -j$:

$$C = 72.0(.01 + j)$$

$$\begin{array}{ll} E_1 = 92.8(1 - .01j) & E'_1 = 78.4(1 - .01j) \\ E_2 = 98.8(-.47 + .88j) & E'_2 = 95.6(-.41 + .91j) \\ E_3 = 98.7(-.48 - .88j) & E'_3 = 94.6(-.41 - .91j) \end{array}$$

4. Inductive line, non-inductive load: $I_1 = -.1j, I_2 = 1$:

$$C = 94.0(.96 + .28j)$$

$$\begin{array}{ll} E_1 = 95.9(.99 + .09j) & E'_1 = 94.1(.96 + .28j) \\ E_2 = 95.2(-.50 + .86j) & E'_2 = 86.1(-.52 + .85j) \\ E_3 = 102.7(-.47 - .88j) & E'_3 = 109.6(-.41 - .91j) \end{array}$$

Remarkable is in 1. and in 4. the *rise of potential* in the line in the branch E'_3 .

Apparently these values look rather irregular, sometimes the one, sometimes the other unloaded branch being higher. Looking closer into it, however, we can not fail to see the regularity displayed in the variation of potential, which makes it possible to control this phenomenon.

Lynn, Mass., July, 1893.

DISCUSSION.

PROF. MACFARLANE:—I wish to make a remark in regard to the fundamental principle of the use of complex quantities. The letter j was first introduced as a distinguishing index without mathematical meaning, and afterwards defined by the equation $j^2 = -1$. Such definition is ambiguous, for it refers to orthogonal projection of a straight line upon another straight line, and the right angle may be at the former straight line or at the latter. The latter case is the ordinary meaning.

It is not true that algebra is limited or bounded by the ordinary complex quantity. There is a more general complex quantity which applies to space, and of which the complex quantity in a plane is only a special case.

MR. STEINMETZ:—In introducing j , first as distinguishing index and then defining it as $\sqrt{-1}$ my object was to introduce the complex quantity in an elementary and graphical manner, without reference to higher mathematics. To make the reasoning more complete, I might have added that the definition $j = \sqrt{-1}$ does not contradict the original definition of j as index without numerical meaning, since in the range of ordinary numbers $\sqrt{-1}$ is meaningless.

From the mathematical standpoint the complex quantity can directly be introduced without further explanation, since in pure mathematics, for instance, the theory of functions, the plane, is known as the standard representation of the complex quantity.

Referring to Prof. Macfarlane's last remark, my meaning is that the complex quantity is the last and most general *algebraic* number. No further generalization of numbers exists which fulfills the fundamental condition of algebraic numbers, that if a product is zero one of the factors must be zero. This is the reason why the complex quantity of the higher order does not prove as useful in space as the algebraic complex quantity in the plane.

The following paper was then read :

GENERAL DISCUSSION OF THE CURRENT FLOW IN TWO MUTUALLY RELATED CIRCUITS CON- TAINING CAPACITY.

BY FREDERICK BEDELL AND ALBERT C. CREHORE.

In a paper presented at the General Meeting of the AMERICAN INSTITUTE OF ELECTRICAL ENGINEERS* at Chicago, June 7, 1892, the problem of finding the current which flows in a single circuit having resistance, self-induction and capacity in series was considered. A general solution was obtained for the current which flows when the impressed electromotive force is any function of the time whatever. This solution was applied to four cases, which arise according to the nature of the particular electromotive force considered, and curves were drawn to illustrate the current in each case in the particular yet representative examples assumed.

It is our present object to study the more general case of two independent circuits, each of which contains resistance, self-induction and capacity, which are connected only by means of their common magnetic field.

Throughout the discussion the following symbols will be used:

R = resistance.

L = coefficient of self-induction (a constant).

M = coefficient of mutual induction (a constant).

C = capacity.

E = (a) constant electromotive force; or

(b) maximum value of harmonic electromotive force.

e = instantaneous value of electromotive force.

*TRANSACTIONS AMERICAN INSTITUTE OF ELECTRICAL ENGINEERS, vol. ix.
p. 308.

- I = (a) constant current ; or
 (b) maximum value of harmonic current.
 i = instantaneous value of current.
 Q = constant charge of condenser.
 q = instantaneous value of charge of condenser.
 $\omega = 2 \pi n = 2 \pi \times$ frequency = angular velocity.
 $+\theta$ = angle of advance.
 $-\theta$ = angle of lag.
 T = (a) period ; or (b) time-constant.
 $j = \sqrt{-1}$.
 e = base of Napierian logarithms = 2.71828.
 c = arbitrary constant of integration.

The meaning of other letters when used will be evident.

It has been shown that the differential equation of energy for a single circuit is

$$e i d t = \frac{i d t \int i d t}{C} + R i^2 d t + L i \frac{d i}{d t} d t, \quad (1)$$

in which the first member represents the total energy imparted to the circuit by the impressed electromotive force. The second member consists of three terms which represent respectively the three ways in which the energy is used in the circuit. The first term is the energy required to charge the condenser ; the second is that expended in heat ; the third is that required to produce the magnetic field.

If a second circuit is now placed in mutual relation to the first, so that they possess a common magnetic field, a fourth term must be added to equation (1) depending upon the coefficient of mutual induction of the two circuits. The equation of energy for the primary coil may be written,

$$e_1 i_1 d t = \frac{i_1 d t \int i_1 d t}{C_1} + R_1 i_1^2 d t + L_1 i_1 \frac{d i_1}{d t} d t + M i_1 \frac{d i_2}{d t} d t, \quad (2)$$

where the subscripts one and two refer to the first and second coil or to the "primary" and "secondary" respectively. The equation of energy for the second coil which has no impressed electromotive force is

$$0 = \frac{i_2 d t \int i_2 d t}{C_2} + R_2 i_2^2 d t + L_2 i_2 \frac{d i_2}{d t} d t + M i_2 \frac{d i_1}{d t} d t. \quad (3)$$

If we divide equation (2) by $i_1 dt$ and equation (3) by $i_2 dt$, we obtain equations of electromotive forces

$$e = f(t) = \frac{\int i_1 dt}{C_1} + R_1 i_1 + L_1 \frac{d i_1}{dt} + M \frac{d i_2}{dt}; \quad (4)$$

$$0 = \frac{\int i_2 dt}{C_2} + R_2 i_2 + L_2 \frac{d i_2}{dt} + M \frac{d i_1}{dt}. \quad (5)$$

In these equations the electromotive force is expressed as a function of the time. The solution of these differential equations will be the complete solution of the problem of circuits with constant coefficients of mutual and self induction, having resistance and capacity, and it will give us the current that flows in either the primary or secondary at any time due to any impressed electromotive force. In order to solve the equations we may eliminate from the pair either i_1 or i_2 and obtain a single equation containing but one independent variable. To perform this elimination we may differentiate (4) and (5) enough times to obtain one more equation than we have variables to eliminate. We may then form a determinant of the coefficients of the variables to be eliminated and proceed in the usual way in elimination by determinants.

If we use the symbols $D = \frac{d}{dt}$, and $D^2 = \frac{d^2}{dt^2}$, etc., equations (4) and (5) may be written

$$f(t) = \frac{\int i_1 dt}{C_1} + R_1 i_1 + L_1 D i_1 + M D i_2; \quad (6)$$

$$0 = \frac{\int i_2 dt}{C_2} + R_2 i_2 + L_2 D i_2 + M D i_1. \quad (7)$$

By differentiation we obtain the six equations

$$f'(t) = \frac{1}{C_1} i_1 + R_1 D i_1 + L_1 D^2 i_1 + M D^2 i_2. \quad (8)$$

$$f''(t) = \frac{1}{C_1} D i_1 + R_1 D^2 i_1 + L_1 D^3 i_1 + M D^3 i_2. \quad (9)$$

$$f'''(t) = \frac{1}{C_1} D^2 i_1 + R_1 D^3 i_1 + L_1 D^4 i_1 + M D^4 i_2. \quad (10)$$

$$0 = \frac{1}{C_2} i_2 + R_2 Di_2 + L_2 D^2i_2 + M D^2i_1. \quad (11)$$

$$0 = \frac{1}{C_2} Di_2 + R_2 D^2i_2 + L_2 D^3i_2 + M D^3i_1. \quad (12)$$

$$0 = \frac{1}{C_2} D^2i_2 + R_2 D^3i_2 + L_2 D^4i_2 + M D^4i_1. \quad (13)$$

In these six equations there are five quantities which it is required to eliminate, viz., $i_1, Di_1, D^2i_1, D^3i_1$ and D^4i_1 , in order to obtain an equation containing only i_2 and the derivatives of i_2 . To obtain a single equation containing i_1 alone, it is necessary to eliminate $i_2, Di_2, D^2i_2, D^3i_2$ and D^4i_2 .

To obtain the equation for primary current, we form a determinant consisting of six columns, five of which contain the coefficients of $i_2, Di_2, D^2i_2, D^3i_2, D^4i_2$, etc., in the equations, while the sixth column contains all quantities in the equations independent of $i_2, Di_2, D^2i_2, D^3i_2, D^4i_2$, etc. Thus, to eliminate i_2 , we may write the determinant,

$i_2, Di_2, D^2i_2, D^3i_2, D^4i_2$	REMAINING TERMS.	
0 0 M 0 0	$\frac{1}{C_1} i_1 + R_1 Di_1 + L_1 D^2i_1 - f'(t)$	= 0.
0 0 0 M 0	$\frac{1}{C_1} Di_1 + R_1 D^2i_1 + L_1 D^3i_1 - f''(t)$	
0 0 0 0 M	$\frac{1}{C_1} D^2i_1 + R_1 D^3i_1 + L_1 D^4i_1 - f'''(t)$	
$\frac{1}{C_2} R_2 L_2 0 0$	MD^2i_1	
0 $\frac{1}{C_2} R_2 L_2 0$	MD^3i_1	
0 0 $\frac{1}{C_2} R_2 L_2$	MD^4i_1	

Since the first column is composed entirely of zeros except the fourth row, the determinant reduces to $\frac{1}{C_2}$ times its minor determinant. One column of this minor determinant is all zeros except one row, so that the determinant reduces to one of the fourth order. By erasing the first and second columns and the fourth and fifth rows of the determinant of the sixth order, it becomes

$$\begin{array}{ccccccc}
 M & 0 & 0 & \frac{1}{C_1} i_1 & + R_1 D i_1 & + L_1 D^2 i_1 & -f' (t) \\
 0 & M & 0 & \frac{1}{C_1} D i_1 & + R_1 D^2 i_1 & + L_1 D^3 i_1 & -f'' (t) \\
 0 & 0 & M & \frac{1}{C_1} D^2 i_1 & + R_1 D^3 i_1 & + L_1 D^4 i_1 & -f''' (t) \\
 \frac{1}{C_2} R_2 & L_2 & & & & & M D^4 i_1
 \end{array} = 0. \tag{15}$$

Multiplied out and expanded, this determinant gives (16)

$$\begin{aligned}
 & \left[(L_1 L_2 - M^2) D^4 + (R_1 L_2 + R_2 L_1) D^3 + \left(\frac{L_1}{C_2} + \frac{L_2}{C_1} + R_1 R_2 \right) D^2 \right. \\
 & \left. + \left(\frac{R_1}{C_2} + \frac{R_2}{C_1} \right) D + \frac{1}{C_1 C_2} \right] i_1 = \frac{1}{C_2} f' (t) + R_2 f'' (t) + L_2 f''' (t).
 \end{aligned}$$

Here we have a differential equation of the fourth order containing but two variables i_1 and t , the solution of which gives the desired primary current in terms of the impressed electromotive force.

The differential equation for the secondary current may be obtained in a similar manner by eliminating i_1 and its derivatives from equations (8) to (13) inclusive. In order to perform the elimination, we may write as before, the determinant

i_1	Di_1	$D^2 i_1$	$D^3 i_1$	$D^4 i_1$	REMAINING TERMS.	
$\frac{1}{C_1}$	R_1	L_1	0	0	$M D^2 i_2 - f' (t)$	
0	$\frac{1}{C_1}$	R_1	L_1	0	$M D^3 i_2 - f'' (t)$	(17)
0	0	$\frac{1}{C_1}$	R_1	L_1	$M D^4 i_2 - f''' (t)$	
0	0	M	0	0	$\frac{1}{C_2} i_2 + R_2 D i_2 + L_2 D^2 i_2$	= 0.
0	0	0	M	0	$\frac{1}{C_1} D i_2 + R_2 D^2 i_2 + L_2 D^3 i_2$	
0	0	0	0	M	$\frac{1}{C_2} D^2 i_2 + R_2 D^3 i_2 + L_2 D^4 i_2$	

Since the first column of this determinant is composed entirely of zeros except the first row, it reduces to the minor of the fifth

order found by erasing the first row and first column. Since the first column of this minor determinant is composed entirely of zeros except its first row, the whole reduces to the determinant of the fourth order found by striking out both the first and second rows and columns. Thus,

$\frac{1}{C_1}$	R_1	L_1	$M D^4 i_2 - f'''(t)$	(18)
M	0	0	$\frac{1}{C_2} i_2 + R_2 D i_2 + L_2 D^2 i_2$	
0	M	0	$\frac{1}{C_2} D i_2 + R_2 D^2 i_2 + L_2 D^3 i_2$	
0	0	M	$\frac{1}{C_2} D^2 i_2 + R_2 D^3 i_2 + L_2 D^4 i_2$	

= 0.

Multiplying out and expanding, we obtain the desired differential equation for the secondary current.

$$\left[(L_1 L_2 - M^2) D^4 + (R_1 L_2 + R_2 L_1) D^3 + \left(\frac{L_1}{C_2} + \frac{L_2}{C_1} + R_1 R_2 \right) D^2 + \left(\frac{R_1}{C_2} + \frac{R_2}{C_1} \right) D + \frac{1}{C_1 C_2} \right] i_2 = -M f''(t).$$

It is noticeable that these differential equations (16) and (19) for the primary and secondary currents are very similar. The first members are alike if we write i_2 for i_1 . The second members show a marked difference. The equation for primary current contains R_2 , L_2 and C_2 , with the three derivatives of $f(t)$, while the equation for secondary current contains only M , with the third derivative of $f(t)$.

The general solutions of these equations of the fourth order, (16) and (19), would give the value of the primary and secondary currents at any time, where the impressed electromotive force is any function whatsoever of the time, and they would involve the literal solution of the general bi-quadratic equation, that we might find four factors of the bi-quadratic expression in order to resolve the inverse operator into four partial fractions. In their full generality, the equations are too cumbersome for practical purposes, but readily admit of solution, as they now stand, if we assume the impressed electromotive force to be harmonic, as will be discussed later in this paper. However, the solutions may be obtained for any impressed electromotive force whatsoever, by the introduction of certain modifications which

reduce the equations to an order lower than the fourth. If the equation can be reduced to the second order, it is comparatively easy to find its general solution; but we will not attempt to write the solution of equations of the third and fourth orders, except in the case of an harmonic impressed electromotive force, which is to be discussed later.

If we omit one of the condensers from the circuit, it will reduce the equations (16) and (19) to the third order, and if we omit both condensers, the equations reduce to the second order. The resulting equations in these particular cases may be written down from (16) and (19) by omitting terms and reducing the accents and the order by the required amount. To see how the order is reduced, we will form the equation in the case where both condensers are omitted. To do this let us return to (6) and (7). Omitting the condenser terms, these equations of electromotive forces become

$$f(t) = R_1 i_1 + L_1 Di_1 + M Di_2. \quad (20)$$

$$0 = R_2 i_2 + L_2 Di_2 + M Di_1. \quad (21)$$

We need differentiate each equation only once to obtain enough equations to eliminate either of the variables i_1 or i_2 .

By differentiation we have

$$f'(t) = R_1 Di_1 + L_1 D^2i_1 + M D^2i_2. \quad (22)$$

$$0 = R_2 Di_2 + L_2 D^2i_2 + M D^2i_1. \quad (23)$$

Forming a determinant of these four equations to eliminate i_2 , we have

i_2	Di_2	D^2i_2	REMAINING TERMS.	
0	M	0	$R_1 i_1 + L_1 Di_1 - f(t)$	= 0. (24)
0	0	M	$R_1 Di_1 + L_1 D^2i_1 - f'(t)$	
R_2	L_2	0	$M Di_1$	
0	R_2	L_2	$M D^2i_1$	

Since the first column is all zeros except the third row, this determinant reduces to

M	0	$R_1 i_1 + L_1 Di_1 - f(t)$	= 0; (25)
0	M	$R_1 Di_1 + L_1 D^2i_1 - f'(t)$	
R_2	L_2	$M D^2i_1$	

and this expanded gives

$$[(L_1L_2 - M^2)D^2 + (R_1L_2 + R_2L_1)D + R_1R_2]i_1 = R_2f(t) + L_2f'(t) \quad (26)$$

Forming the determinant to eliminate i_2 , we have

i_1	Di_1	D^2i_1	REMAINING TERMS.	
R_1	L_1	0	$M Di_2 - f(t)$	= 0. (27)
0	R_1	L_1	$M D^2i_2 - f'(t)$	
0	M	0	$R_2 i_2 + L_2 Di_2$	
0	0	M	$R_2 Di_2 + L_2 D^2i_2$	

This reduces to

R_1	L_1	$M D^2 i_2 - f'(t)$	= 0; (28)
M	0	$R_2 i_2 + L_2 D i_2$	
0	M	$R_2 D i_2 + L_2 D^2 i_2$	

and, when expanded, gives

$$[(L_1L_2 - M^2)D^2 + (R_1L_2 + R_2L_1)D + R_1R_2]i_2 = -Mf''(t) \quad (29)$$

Upon comparing (26) and (29) with (16) and (19) we see that we might have written both (26) and (29) immediately from the more general forms, by reducing each exponent and accent by two and omitting all terms containing C_1 or C_2 .

In a similar manner we may find the equations of the third order from the general by omitting one condenser only. If we omit the primary condenser only, we may write from the general the equation in this particular case by reducing all exponents and accents by unity and omitting terms containing C_1 . Thus, omitting C_1 from the primary, we have for the primary current

$$\begin{aligned} & \left[(L_1L_2 - M^2)D^3 + (R_1L_2 + R_2L_1)D^2 + \left(\frac{L_1}{C_2} + R_1R_2 \right)D + \frac{R_1}{C_2} \right] i_1 \\ & = \frac{1}{C_2} f(t) + R_2 f'(t) + L_2 f''(t). \end{aligned} \quad (30)$$

The secondary current equation becomes

$$\begin{aligned} & \left[(L_1L_2 - M^2)D^3 + (R_1L_2 + R_2L_1)D^2 + \left(\frac{L_1}{C_2} + R_1R_2 \right)D + \frac{R_1}{C_2} \right] i_2 \\ & = -Mf''(t). \end{aligned} \quad (31)$$

If the secondary condenser is omitted, the equations (16) and (19) become

$$\begin{aligned} & \left[(L_1L_2 - M^2)D^3 + (R_1L_2 + R_2L_1)D^2 + \left(\frac{L_2}{C_1} + R_1R_2 \right)D + \frac{R_2}{C_1} \right] i_1 \\ & = R_2 f'(t) + L_2 f''(t); \end{aligned} \quad (32)$$

and

$$\left[(L_1 L_2 - M^2) D^3 + (R_1 L_2 + R_2 L_1) D^2 + \left(\frac{L_2}{C_1} + R_1 R_2 \right) D + \frac{R_2}{C_1} \right] i_2 = -M f''(t). \quad (33)$$

Another consideration which will enable us to reduce the order of our equations is that of no magnetic leakage. If we consider that all the lines of induction generated by the primary circuit thread the secondary, it is well known that the product the coefficients of self-induction equals the square of the coefficient of mutual induction of the two circuits; that is, $L_1 L_2 = M^2$, or $L_1 L_2 - M^2 = 0$. This approximation is so nearly realized in most of the closed magnetic circuit transformers that it is worth while to consider how it simplifies the equations. The coefficient of the terms of the highest order in any of the differential equations yet written is this quantity $L_1 L_2 - M^2$. If we consider, therefore, that there is no magnetic leakage in the transformer, we may reduce the general equations (16) and (19) to the third order. It will not be attempted here to write down the general solution of the equation of the third order. However, if we wish to consider the case where only one condenser is in circuit and there is no magnetic leakage, equations (30) to (33) inclusive reduce to the second order and can be readily solved. When there is no condenser in either circuit, equations (26) and (29) reduce to very simple forms, being of the first order when the consideration of no magnetic leakage is introduced. Upon the solution of these equations of the first order, in the case of an harmonic electromotive force, may be established the well-known transformer diagram usually built up geometrically by a synthetic process.

It is now proposed to obtain the general solutions of equations (26) and (29) which give the complete solution of the problem of two mutually related circuits without considering condensers, but with no limiting assumptions in regard to the magnetic leakage. Then will be given the solution of the same case simplified by the assumption that there is no magnetic leakage. Lastly, the cases will be considered where there is no magnetic leakage, and one of the circuits contains a condenser.

At this point the meeting adjourned to convene the next day at 10 o'clock, Thursday August 24th; the section was called to order by the secretary, Dr. Kimball, in the absence of the chairman and vice-chairman. Dr. Henry T. Eddy, President of

Rose Polytechnic Institute, Terre Haute, was nominated and elected as temporary chairman.

The reading of the paper started the previous day was then continued.

II.

GENERAL SOLUTION FOR THE CURRENTS IN TWO MUTUALLY RELATED CIRCUITS WITH NO CONDENSER.

In symbolic notation (see Johnson's Differential Equations Chap. V.), equations (26) and (29) may be written

$$i_1 = \frac{1}{D^2 + \frac{R_1 L_2 + R_2 L_1}{L_1 L_2 - M^2} D + \frac{R_1 R_2}{L_1 L_2 - M^2}} [R_2 f(t) + L_2 f'(t)], \quad (34)$$

and

$$i_2 = \frac{-1}{D^2 + \frac{R_1 L_2 + R_2 L_1}{L_1 L_2 - M^2} D + \frac{R_1 R_2}{L_1 L_2 - M^2}} \frac{M f'(t)}{L_1 L_2 - M^2}. \quad (35)$$

Resolving the inverse operator into partial fractions, we have the identical equation

$$\begin{aligned} & \frac{1}{D^2 + \frac{R_1 L_2 + R_2 L_1}{L_1 L_2 - M^2} D + \frac{R_1 R_2}{L_1 L_2 - M^2}} \\ &= \frac{L_1 L_2 - M^2}{\sqrt{(R_1 L_2 + R_2 L_1)^2 - 4 R_1 R_2 (L_1 L_2 - M^2)}} \left\{ \frac{1}{D + \tau_1} - \frac{1}{D + \tau_2} \right\}. \end{aligned} \quad (36)$$

The radical expression which occurs in equation (36) may be written

$$\sqrt{(R_1 L_2 + R_2 L_1)^2 - 4 R_1 R_2 (L_1 L_2 - M^2)} = \frac{\sqrt{(R_1 L_2 - R_2 L_1)^2 + 4 R_1 R_2 M^2}}{L_1 L_2 - M^2}.$$

For simplification, the abbreviations have been used :

$$\tau_1 = \frac{R_1 L_2 + R_2 L_1 - \sqrt{(R_1 L_2 - R_2 L_1)^2 + 4 R_1 R_2 M^2}}{2(L_1 L_2 - M^2)}, \quad (37)$$

and

$$\tau_2 = \frac{R_1 L_2 + R_2 L_1 + \sqrt{(R_1 L_2 - R_2 L_1)^2 + 4 R_1 R_2 M^2}}{2(L_1 L_2 - M^2)}. \quad (38)$$

Placing (36) in (34), we obtain

$$i_1 = \frac{1}{\sqrt{(R_1 L_2 - R_2 L_1)^2 + 4 R_1 R_2 M^2}} \left\{ \frac{R_2 f(t) + L_2 f'(t)}{D + \tau_1} - \frac{R_2 f(t) + L_2 f'(t)}{D + \tau_2} \right\}. \quad (40)$$

Similarly (35) becomes

$$i_2 = \frac{M}{\sqrt{(R_1 L_2 - R_2 L_1)^2 + 4 R_1 R_2 M^2}} \left\{ \frac{f'(t)}{D + \tau_1} - \frac{f'(t)}{D + \tau_2} \right\}. \quad (41)$$

Now the linear equation of the first order may be written

$$y = \frac{1}{D + a} f(x),$$

and its solution is known to be

$$y = e^{-ax} \int e^{ax} f(x) dx + c e^{-ax}.$$

Hence we have

$$\frac{f(x)}{D + a} = e^{-ax} \int e^{ax} f(x) dx + c e^{-ax}. \quad (42)$$

Replacing $f(x)$ by $R_2 f(t)$, and a by τ_1 in this general formula, we have,

$$\frac{R_2 f(t)}{D + \tau_1} = R_2 e^{-\tau_1 t} \int e^{\tau_1 t} f(t) dt + c e^{-\tau_1 t}. \quad (43)$$

Similarly we should find

$$\frac{L_2 f'(t)}{D + \tau_1} = L_2 e^{-\tau_1 t} \int e^{\tau_1 t} f'(t) dt + c e^{-\tau_1 t}, \quad (44)$$

and also

$$\frac{M f'(t)}{D + \tau_1} = M e^{-\tau_1 t} \int e^{\tau_1 t} f'(t) dt + c e^{-\tau_1 t}. \quad (45)$$

Substituting these values in (40) and (41), we obtain for the primary current

$$i_1 = \frac{1}{\sqrt{(R_1 L_2 - R_2 L_1)^2 + 4 R_1 R_2 M^2}} \left\{ e^{-\tau_1 t} \int e^{\tau_1 t} [R_2 f(t) + L_2 f'(t)] dt - e^{-\tau_2 t} \int e^{\tau_2 t} [R_2 f(t) + L_2 f'(t)] dt \right\} + c_1 e^{-\tau_1 t} + c_2 e^{-\tau_2 t}; \quad (46)$$

and for the secondary current

$$i_2 = \frac{-M}{\sqrt{(R_1 L_2 - R_2 L_1)^2 + 4 R_1 R_2 M^2}} \left\{ e^{-\tau_1 t} \int e^{\tau_1 t} f'(t) dt - e^{-\tau_2 t} \int e^{\tau_2 t} f'(t) dt \right\} + c_3 e^{-\tau_1 t} + c_4 e^{-\tau_2 t}. \quad (47)$$

These equations, (46) and (47), are the complete solutions for the current flowing in two mutually related circuits, containing no condenser, with no assumption in regard to magnetic leakage. It is noticed, (37) and (38), that there are two time constants, as in the case of capacity and self induction in a single circuit; but no oscillatory effect can be obtained in this case, because the expression under the radical is always real for all values of the constants R , M , or L . Further discussion will be deferred until the equations for the other cases are found.

GENERAL SOLUTION FOR TWO MUTUALLY RELATED CIRCUITS IN WHICH THERE IS NO CONDENSER, ASSUMING NO MAGNETIC LEAKAGE.

Upon the introduction of the condition of no leak in equations (26) and (29), *i.e.*, equating $L_1 L_2 - M^2$ to zero they become

$$\left[D + \frac{R_1 R_2}{R_1 L_2 + R_2 L_1} \right] i_1 = \frac{R_2 f(t) + L_2 f'(t)}{R_1 L_2 + R_2 L_1}, \quad (48)$$

and

$$\left[D + \frac{R_1 R_2}{R_1 L_2 + R_2 L_1} \right] i_2 = \frac{-M f'(t)}{R_1 L_2 + R_2 L_1}. \quad (49)$$

The solution of these linear equations of the first order may be written by means of the general formula (42), and we have

$$i_1 = \frac{\epsilon^{-\tau t}}{R_1 L_2 + R_2 L_1} \int \epsilon^{\tau t} [R_2 f(t) + L_2 f'(t)] dt + c_1 \epsilon^{-\tau t}, \quad (50)$$

and

$$i_2 = -\frac{M}{R_1 L_2 + R_2 L_1} \epsilon^{-\tau t} \int \epsilon^{\tau t} f'(t) dt + c_2 \epsilon^{-\tau t}, \quad (51)$$

where

$$\tau = \frac{R_1 R_2}{L_1 R_2 + L_2 R_1}. \quad (52)$$

These equations might have been written from the general solutions (46) and (47), but it is easier to derive them independently from the differential equations. It is remarkable how much the consideration of no magnetic leakage simplifies the mathematical expression of the results.

Before entering upon the discussion of these results it is thought best to obtain the equations for the case in which there is a condenser in one of the circuits, where there is no magnetic leakage.

GENERAL SOLUTION FOR TWO MUTUALLY RELATED CIRCUITS
WITH A CONDENSER IN ONE CIRCUIT, ASSUMING NO MAGNETIC LEAKAGE.

The solutions may be obtained from the differential equations (30) to (33), after equating $L_1 L_2 - M^2$ to zero. With this supposition, when we have the secondary condenser only, the equations become

$$i_1 = \frac{1}{D^2 + \frac{\left(\frac{L_1}{C_2} + R_1 R_2\right)}{R_1 L_2 + R_2 L_1} D + \frac{R_1}{C_2(R_1 L_2 + R_2 L_1)}} \frac{\frac{1}{C_2} f(t) + R_2 f'(t) + L_2 f''(t)}{R_1 L_2 + R_2 L_1} \quad (53)$$

$$i_2 = \frac{-1}{D^2 + \frac{\frac{L_1}{C_2} + R_1 R_2}{R_1 L_2 + R_2 L_1} D + \frac{R_1}{C_2(R_1 L_2 + R_2 L_1)}} \frac{M f''(t)}{R_1 L_2 + R_2 L_1} \quad (54)$$

With the primary condenser only, they become

$$i_1 = \frac{1}{D^2 + \frac{\frac{L_2}{C_1} + R_1 R_2}{R_1 L_2 + R_2 L_1} D + \frac{R_2}{C_1(R_1 L_2 + R_2 L_1)}} \frac{R_2 f'(t) + L_2 f''(t)}{R_1 L_2 + R_2 L_1}, \quad (55)$$

and

$$i_2 = \frac{-1}{D^2 + \frac{\frac{L_2}{C_1} + R_1 R_2}{R_1 L_2 + R_2 L_1} D + \frac{R_2}{C_1(R_1 L_2 + R_2 L_1)}} \frac{M f''(t)}{R_1 L_2 + R_2 L_1}. \quad (56)$$

Resolving the inverse operator in (53) and (54) into partial fractions, we have the identity

$$\begin{aligned} & \frac{1}{D^2 + \frac{\left(\frac{L_1}{C_2} + R_1 R_2\right)}{R_1 L_2 + R_2 L_1} D + \frac{R_1}{R_1 L_2 + R_2 L_1}} \\ &= \frac{R_1 L_2 + R_2 L_1}{\sqrt{\left(\frac{L_1}{C_2} + R_1 R_2\right)^2 - 4R_1(R_1 L_2 + R_2 L_1)}} \left\{ \frac{1}{D + \tau_1''} - \frac{1}{D + \tau_2''} \right\}, \end{aligned} \quad (57)$$

where, for abbreviation,

$$\tau_1'' = \frac{\frac{L_1}{C_2} + R_1 R_2 + \sqrt{\left(\frac{L_1}{C_2} + R_1 R_2\right)^2 - 4R_1(R_1 L_2 + R_2 L_1)}}{2(R_1 L_2 + R_2 L_1)}, \quad (58)$$

$$\tau_2'' = \frac{\frac{L_1}{C_2} + R_1 R_2 - \sqrt{\left(\frac{L_1}{C_2} + R_1 R_2\right)^2 - 4R_1(R_1 L_2 + R_2 L_1)}}{2(R_1 L_2 + R_2 L_1)}. \quad (59)$$

Equations (55) and (56), for the case of the primary condenser only, may be similarly treated by interchanging $R_1, L_1, C_1, \tau_1', \tau_2'$, with $R_2, L_2, C_2, \tau_2'', \tau_1''$, where, for the primary condenser, we have the abbreviations

$$\tau_1' = \frac{\frac{L_1}{C_2} + R_1 R_2 + \sqrt{\left(\frac{L_1}{C_1} + R_1 R_2\right)^2 - 4R_2(R_1 L_2 + R_2 L_1)}}{2(R_1 L_2 + R_2 L_1)}. \quad (60)$$

$$\tau_2' = \frac{\frac{L_2}{C_1} + R_1 R_2 - \sqrt{\left(\frac{L_2}{C_1} + R_1 R_2\right)^2 - 4R_2(R_1 L_2 + R_2 L_1)}}{2(R_1 L_2 + R_2 L_1)}. \quad (61)$$

This method of obtaining the solution which has previously been given, (34) to (47), finally gives the integral equations in the case of one condenser with the consideration of no leak.

For the case in which there is a condenser in the secondary and no leak, the solutions are

$$i_1 = \frac{1}{\sqrt{\left(\frac{L_1}{C_2} + R_1 R_2\right)^2 - 4R_1(R_1 L_2 + R_2 L_1)}} \left\{ \epsilon^{-\tau_2'' t} \int_{\tau_2'' t}^{\tau_1'' t} \left[\frac{1}{C_2} f(t) + R_2 f'(t) + L_2 f''(t) \right] dt + \epsilon^{-\tau_1'' t} \int_{\tau_1'' t}^{\tau_2'' t} \times \right. \quad (62)$$

$$\left. \left[\frac{1}{C_2} f(t) + R_2 f'(t) + L_2 f''(t) \right] dt \right\} + c_1 \epsilon^{-\tau_1'' t} + c_2 \epsilon^{-\tau_2'' t}.$$

$$i_2 = \frac{M}{\sqrt{\left(\frac{L_1}{C_2} + R_1 R_2\right)^2 - 4R_1(R_1 L_2 + R_2 L_1)}} \quad (63)$$

$$\left\{ \epsilon^{-\tau_1'' t} \int_{\tau_1'' t}^{\tau_2'' t} f''(t) dt - \epsilon^{-\tau_2'' t} \int_{\tau_2'' t}^{\tau_1'' t} f''(t) dt \right\} + c_3 \epsilon^{-\tau_1'' t} + c_4 \epsilon^{-\tau_2'' t}.$$

When there is a condenser in the primary alone, and no leak, the solutions are

$$i_1 = \frac{1}{\sqrt{\left(\frac{L_2}{C_1} + R_1 R_2\right)^2 - 4R_2(R_1 L_2 + R_2 L_1)}} \times$$

$$\left\{ \varepsilon^{-\tau_1 t} \int \varepsilon^{\tau_1 t} [R_2 f'(t) + L_2 f''(t)] dt - \varepsilon^{-\tau_1 t} \int \varepsilon^{\tau_1 t} [R_2 f'(t) + L_2 f''(t)] dt \right\} + c_3 \varepsilon^{-\tau_1 t} + c_6 \varepsilon^{-\tau_2 t} \quad (64)$$

$$i_2 = \frac{M}{\sqrt{\left(\frac{L_2}{C_1} + R_1 R_2\right)^2 - 4R_2(R_1 L_2 + R_2 L_1)}} \quad (65)$$

$$\left\{ \varepsilon^{-\tau_1 t} \int \varepsilon^{\tau_1 t} f''(t) dt - \varepsilon^{-\tau_2 t} \int \varepsilon^{\tau_2 t} f''(t) dt \right\} + c_7 \varepsilon^{-\tau_1 t} + c_8 \varepsilon^{-\tau_2 t}.$$

We have now obtained the equations for current flow under various conditions in regard to magnetic leakage and the location of condensers. The solutions have thus far been general; that is, there have been no limitations in regard to the nature of the impressed electromotive force, which may be any function whatsoever of the time. In (46) and (47) we have the expressions for current flow when there are no condensers, without limitation in regard to there being no magnetic leakage. In (50) and (51) we have the same simplified by the assumption of no leakage. Equations (62) and (63) are the solutions in case of no leak and a secondary condenser; and (64) and (65) are the same for a primary condenser. These general solutions will now be interpreted in turn for certain particular impressed electromotive forces, after which the solution in case of two condensers and no assumption as to absence of magnetic leak will be taken up for an harmonic impressed electromotive force.

DISCUSSION OF THE GENERAL SOLUTION FOR THE CURRENTS IN TWO MUTUALLY RELATED CIRCUITS WITH NO CONDENSER.

Equations (46) and (47) are the general expressions for the current flowing in two mutually related circuits due to any electromotive force whatsoever impressed upon one of them. Each equation consists of a particular integral and a complimentary function containing two arbitrary constants of integration to be determined according to the imposed conditions. In order to perform the operations indicated in the particular integrals, in which the electromotive force is expressed as $f(t)$, it is necessary to assume the electromotive force to be some particular function of the time.

GENERAL CASE OF "MAKE" OR "BREAK."

Ordinarily this would be the case in which initially the two currents are zero and a certain electromotive force is suddenly impressed; or, the case in which initially the two currents have certain assigned values, and the electromotive force is suddenly reduced to zero. All the cases of make or break, that is, the introduction or the removal of the electromotive force, may be generally stated thus: the initial conditions are a primary current I' and secondary current I'' , due to some primary impressed electromotive force, the exact nature of which is immaterial; this electromotive force is suddenly changed to a certain known electromotive force. The initial or final values of any of these electromotive forces or currents may be zero.

Let us suppose that the final value of the impressed electromotive force is a constant, $e = f'(t) = E'$. Substituting $f(t) = E'$ and $f''(t) = 0$ in the general equations (46) and (47), and performing the indicated integrations, we obtain for the primary and secondary currents,

$$i_1 = \frac{E'}{R_1} + c_1 \epsilon^{-r_1 t} + c_2 \epsilon^{-r_2 t}, \quad (66)$$

$$i_2 = c_3 \epsilon^{-r_1 t} + c_4 \epsilon^{-r_2 t}. \quad (67)$$

The arbitrary constants of integration in these complementary functions are to be obtained according to the conditions of the problem. Let I stand for the final steady value $\frac{E'}{R_1}$ of the primary current. Counting time from the time of alteration of the primary electromotive force, we have

When $t = 0$, $i_1 = I' = I + c_1 + c_2$,
and (68)

$$i_2 = I'' = c_3 + c_4.$$

This gives two equations in which there are four unknown arbitrary constants to be determined, and evidently two more equations must be obtained before they can be found. These equations may be formed from the consideration of the quantities of electricity which will flow in the two circuits while the magnetic field is changing, on account of the change in the impressed electromotive force. The number of lines initially threading the primary circuit is $L_1 I'$ due to the primary current, plus $M I''$ lines due to the secondary; finally, when the primary current

has the steady value I , the number of lines will be $L_1 I$. The quantity of electricity (in c. g. s. units) which will flow in the primary, *due to the change in the magnetic field*, will be equal to the change in lines divided by the resistance, or

$$Q_1 = \frac{L_1 I' + M I'' - L_1 I}{R_1}.$$

Similarly, the initial number of lines threading the secondary will be $L_2 I' + M I''$, which will change to the final value $M I$; whence

$$Q_2 = \frac{L_2 I' + M I'' - M I}{R_2}.$$

Now these values of the quantities of electricity, in primary and secondary, may be obtained from the integrals of the current equations. The integrals of (66) and (67) between the limits zero and infinity, will give the quantities of electricity which will flow during an infinite time from the time of changing the impressed electromotive force; thus, from (66),

$$\int_{t=0}^{t=\infty} i_1 dt = I t_\infty + \frac{c_1}{\tau_1} + \frac{c_2}{\tau_2}.$$

Now the first term in the second member is the quantity which will flow, due to the final steady current $I = \frac{E'}{R_1}$, and the remaining two terms represent the quantity which will flow, due to the change in the magnetic field, or

$$Q_1 = \frac{c_1}{\tau_1} + \frac{c_2}{\tau_2}.$$

The secondary flow, from (67), is

$$Q_2 = \int_{t=0}^{t=\infty} i_2 dt = \frac{c_3}{\tau_1} + \frac{c_4}{\tau_2}.$$

This gives us the two additional equations containing the unknown arbitrary constants. From these two equations and the two before obtained (68), the four constants are found to be

$$\begin{aligned} c_1 &= \frac{\tau_1 (\tau_2 Q_1 + I - I')}{\tau_2 - \tau_1}, \\ c_2 &= \frac{\tau_2 (I' - I - \tau_1 Q_1)}{\tau_2 - \tau_1}, \\ c_3 &= \frac{\tau_1 (\tau_2 Q_2 - I'')}{\tau_2 - \tau_1}, \end{aligned}$$

$$e_4 = \frac{\tau_2 (I'' - \tau_1 Q_2)}{\tau_2 - \tau_1}.$$

Equations (66) and (67), with these values substituted for the arbitrary constants of integration, give the values of primary and secondary currents at any time after the alteration of the primary impressed electromotive force. The values of τ_1 and τ_2 so depend upon the constants of the circuits that they are always real, and so the change of the currents from their initial to final values is gradual and non-oscillatory.

The nature of this change in the currents is shown by the typical curves in Fig. 1 representing a case in which the primary current is changed from a value $o A$ to a final value $o B$, the

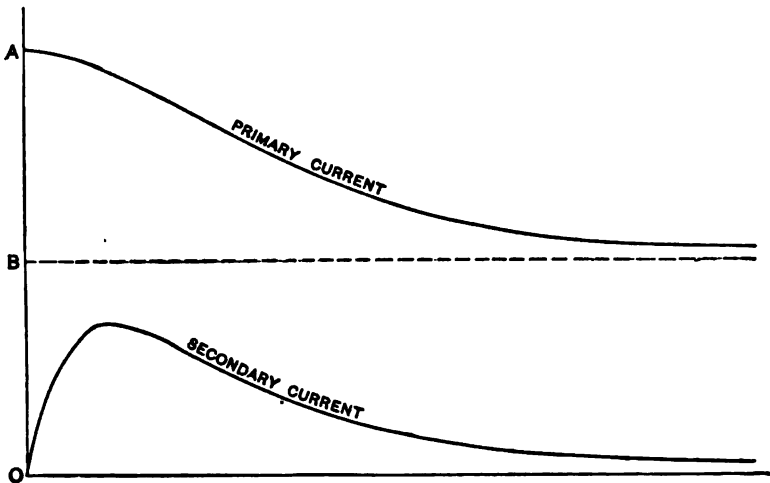

FIG. 1.

secondary current rising from zero to a maximum, and gradually dying away to zero again. In all cases where the primary is either increased or decreased from one steady value to another by make or break, the secondary current curve would have a shape similar to that shown. The primary current curve as shown is typical for any case of decrease, either to a finite steady value or to zero; if inverted, it would show the change for a corresponding increase.

CASE OF NO MAGNETIC LEAKAGE.

In the hypothetical case of no magnetic leakage the equations take the simpler forms of (50) and (51). According to these equations, the change of the primary and secondary currents

from initial to final values, due to a change of the primary impressed electromotive force from its initial to a final steady value, would be represented by exponential curves. Fig. 2 typically represents such a change. The primary current is changed from a value oA to a final steady value oB in the opposite direction, the total change being represented by ΔB . The secondary current is represented by an exponential curve with initial value oC , and final value zero. Now in the case supposed, the secondary current will be initially zero, and to follow this exponential

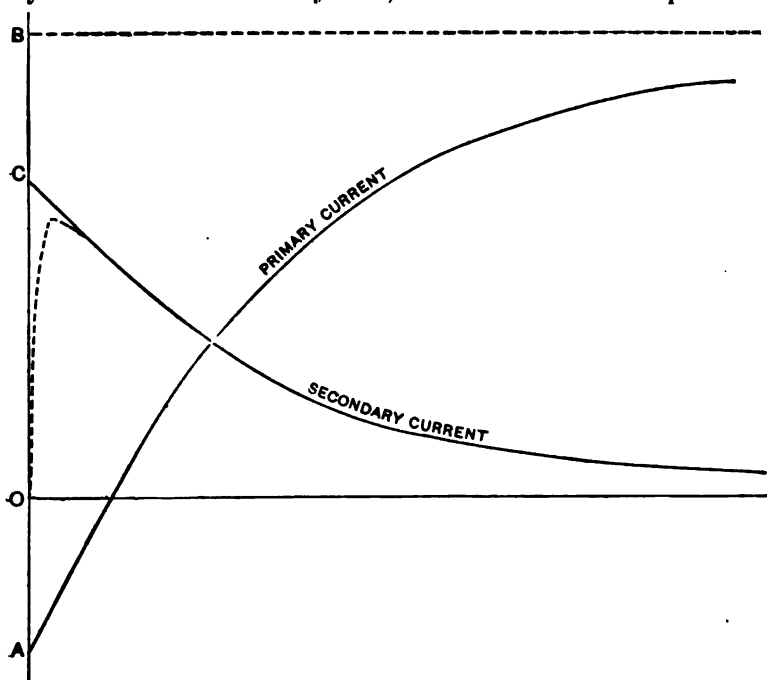

FIG. 2.

law it would have to immediately assume the value oC . Evidently this is impossible, and it shows that the case of absolutely no magnetic leakage is hypothetical. The dotted line shows the nature of the rise from zero, giving a curve as that shown in Fig. 1.

DISCUSSION OF CASE OF MUTUALLY RELATED CIRCUITS CONTAINING A CONDENSER.

Let us first consider the case in which there is a condenser in the secondary circuit. The general case of make or break will

be treated as before by assuming the primary and secondary currents to be initially I' and I'' respectively, and the impressed electromotive force to be altered to a constant value E' . The expressions for the currents in the primary and secondary at any time t after the change, may be found directly from equations (62) and (63) by substituting $f(t) = E'$, $f'(t) = 0$, and $f''(t) = 0$. Making these substitutions and performing the integrations indicated we obtain

$$i_1 = \frac{E'}{R_1} + c_1 \varepsilon^{-\tau_1'' t} + c_2 \varepsilon^{-\tau_2'' t}, \quad (69)$$

$$i_2 = c_3 \varepsilon^{-\tau_1'' t} + c_4 \varepsilon^{-\tau_2'' t}. \quad (70)$$

These equations are similar to (66) and (67) already discussed, and when the constants τ_1'' and τ_2'' are real, the phenomena attending the make or break do not differ from those already referred to, illustrated in Fig. 1, and need no further explanation.

OSCILLATORY CASE.

The constants of the two circuits may have such values, however, that the constants τ_1'' and τ_2'' are imaginary, in which case the equations (69) and (70) may be transformed, by means of the exponential values of the sine and cosine, into a real form. By referring to the values of the constants τ_1'' and τ_2'' given in (58) and (59), we can note whether these values are real or imaginary, and whether or not a transformation is necessary. When

$\left(\frac{L_1}{C_2} + R_1 R_2\right)^2$ is greater than $4 R_1 (R_1 L_2 + R_2 L_1)$, the values of τ_1'' and τ_2'' are real, and the equations (69) and (70) may be interpreted as (66) and (67); that is, there is no oscillation.

When $\left(\frac{L_1}{C_2} + R_1 R_2\right)^2$ is less than $4 R_1 (R_1 L_2 + R_2 L_1)$, the values of τ_1'' and τ_2'' become imaginary. Equations (69) and (70) can be transformed, however, into the real forms,

$$i_1 = \frac{E'}{R_1} + A_1 \varepsilon^{-p t} \sin(\alpha t + \Phi_1), \quad (71)$$

$$i_2 = A_2 \varepsilon^{-p t} \sin(\alpha t + \Phi_2). \quad (72)$$

In the equations A_1 , A_2 , Φ_1 , Φ_2 , are constants of integration, which may be determined from the supposed conditions; p and α are constants depending upon the constants of the circuit, thus:

$$p = \frac{L_1}{C_2} + R_1 R_2 \quad (73)$$

$$2(R_1 L_2 + R_2 L_1)$$

$$a = \frac{\sqrt{\left(\frac{L_1}{C_2} + R_1 R_2\right)^2 - 4 R_1 (R_1 L_2 + R_2 L_1)}}{3 (R_1 L_2 + R_2 L_1)} \quad (74)$$

Equations (71) and (72) show that both primary and secondary currents will oscillate harmonically about their final values with

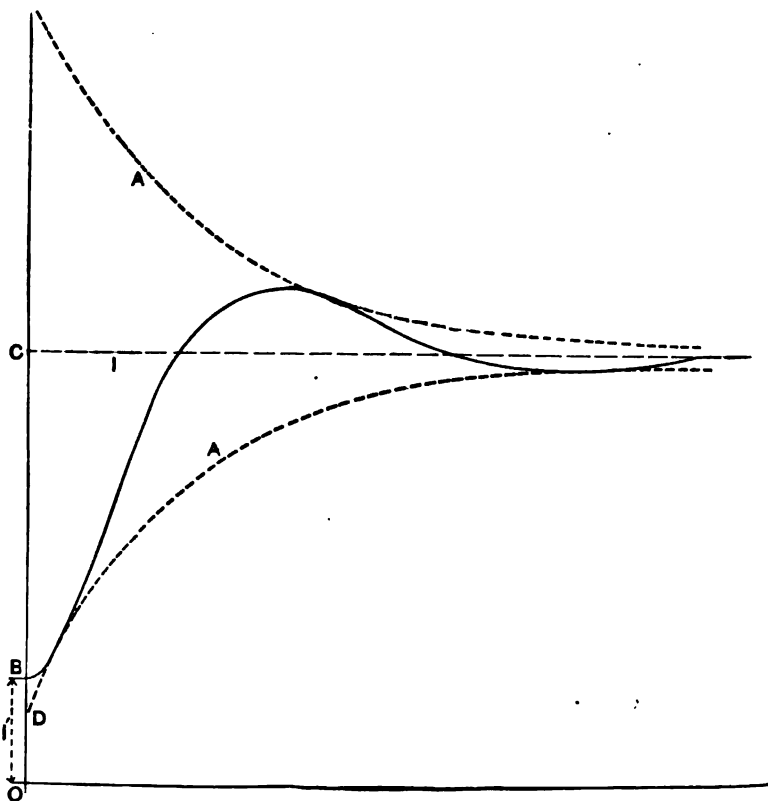

FIG. 3.

a period equal to $\frac{2\pi}{a}$, the maximum values of the oscillations decreasing rapidly with a logarithmic decrement depending upon the value of p . The final steady value of the primary current will be $\frac{E'}{R_1}$, and the secondary will become zero after a short interval of time. The amplitude of the oscillations depends upon

the values of A_1 and A_2 ; their relative phase upon the values of ϕ_1 and ϕ_2 .

The nature of these oscillations will be more clearly understood by inspection of the typical curves in Figs. 3, 4 and 5. Fig. 3 represents the value of the primary current at each point of time as it changes from an initial value I' to a final value I .

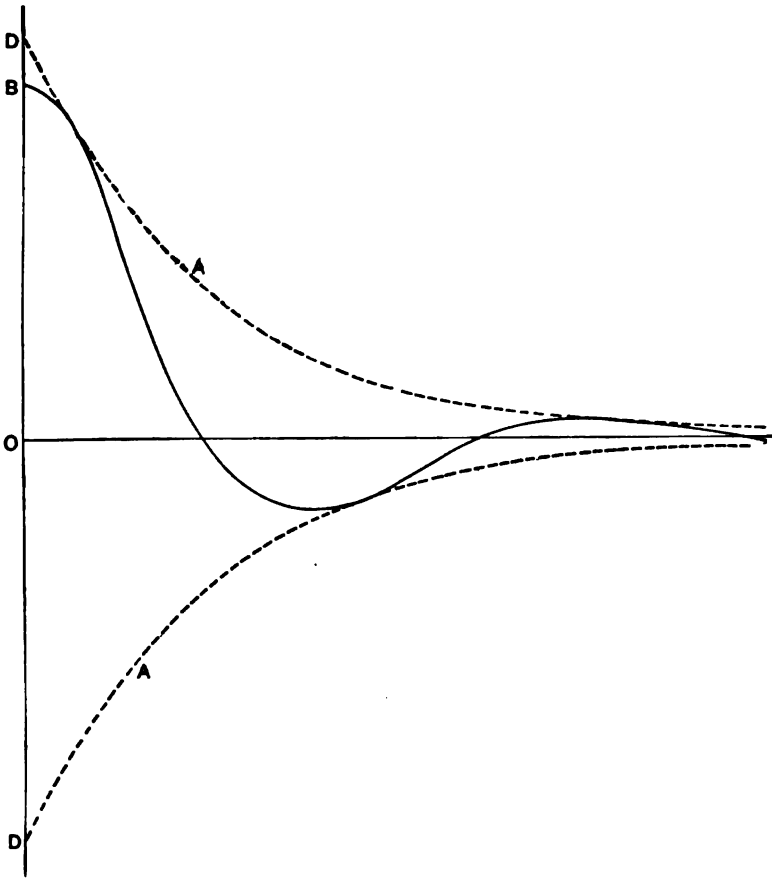

FIG. 4.

The distance BC represents the difference between the initial and final currents. The curve lies between two logarithmic envelopes AA , the initial value of which is equal to A_1 in equation (71), the rate of decay depending upon p . The relation of I' and I to the origin is immaterial; either may be the greater or may be zero. If the initial value I' is zero, the origin should be moved from O to B . If the initial value is not zero and the

final value is zero, the oscillations are as shown in Fig. 4. Where both initial and final values are zero, the curve in Fig. 5 shows the instantaneous values of the primary current.

The oscillations in the secondary circuit are similar in general character to those in the primary. The nature of the oscillations in the secondary current, as it changes from an initial value OB to a final steady value, is shown by Fig. 4. Fig. 5 shows the same with the secondary current initially zero.

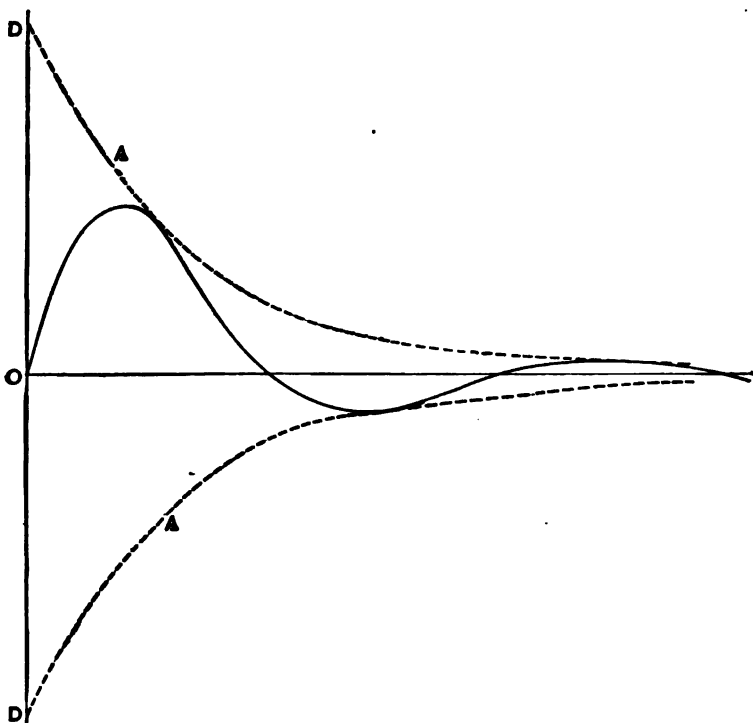

FIG. 5.

The foregoing explanation of the oscillations caused by make or break, when the secondary circuit contains a condenser, is simply the interpretation of equations (62) and (63). If the condenser be placed in the primary circuit instead of the secondary, the phenomena will in many respects be the same as those just described, inasmuch as the equations (64) and (65) for the currents in this case are similar to (62) and (63) for the secondary condenser, and a detailed discussion is accordingly unnecessary.

HARMONIC IMPRESSED ELECTROMOTIVE FORCE.

PRIMARY CURRENT.

In taking up the discussion of current flow when the electromotive force impressed upon the primary is harmonic, let us return to the most general expressions for the primary and secondary currents—the differential equations (16) and (19)—and assume the electromotive force to have a value $E \sin \omega t$.

Substituting in (16):

$$\begin{aligned} f(t) &= E \sin \omega t; & f''(t) &= -E \omega^2 \sin \omega t; \\ f'(t) &= E \omega \cos \omega t; & f'''(t) &= -E \omega^3 \cos \omega t; \end{aligned}$$

the expression for primary current is obtained:

$$i_1 = \frac{\frac{E\omega}{C_2} \cos \omega t - R_2 E \omega^3 \sin \omega t - L_2 E \omega^3 \cos \omega t}{(L_1 L_2 - M^2) D^4 + (R_1 L_2 + R_2 L_1) D^2 + \left[\frac{L_1}{C_2} + \frac{L_2}{C_1} + R_1 R_2 \right] D^2 + \left[\frac{R_1}{C_2} + \frac{R_2}{C_1} \right] D + \frac{1}{C_1 C_2}} \quad (75)$$

Now

$D \sin \omega t = \omega \cos \omega t$, and $D^2 \sin \omega t = -\omega^2 \sin \omega t$
whence

$$D^2 = -\omega^2, \text{ and } D^4 = \omega^4.$$

The numerator in (75) may be written as one term by the trigonometric formula,

$$A \sin \theta + B \cos \theta = \sqrt{A^2 + B^2} \sin \left(\theta + \tan^{-1} \frac{B}{A} \right). \quad (76)$$

Combining the numerator in this manner, substituting $-\omega^2$ and ω^4 for D^2 and D^4 , and multiplying by D , we may write (75) thus:

$$i_1 = \frac{DE\omega^3 \sqrt{R_2^2 + \left(\frac{1}{C_2 \omega} - L_2 \omega \right)^2} \sin \left\{ \omega t - \tan^{-1} \left(\frac{1}{C_2 R_2 \omega} - \frac{L_2 \omega}{R_2} \right) \right\}}{aD + \omega \beta} \quad (77)$$

where

$$a = \omega^4 (L_1 L_2 - M^2) - \omega^2 \left(\frac{L_1}{C_2} + \frac{L_2}{C_1} + R_1 R_2 \right) + \frac{1}{C_1 C_2}; \quad (78)$$

$$\beta = \omega^3 (R_1 L_2 + R_2 L_1) - \omega \left(\frac{R_1}{C_2} + \frac{R_2}{C_1} \right). \quad (79)$$

To free (77) from the operator D , operate upon the numerator as indicated, and multiply numerator and denominator by $aD - \omega \beta$. Substitute $-\omega^2$ for D^2 , and perform the operation D in the numerator. Having now become rid of the operator D ,

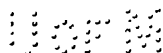

we have the required integral, which expresses the value of the primary current at any time. Thus:

$$i_1 = I_1 \sin (\omega t + \Phi), \quad (80)$$

where

$$I_1 = \frac{E \omega^2 \sqrt{R_2^2 + \left(\frac{1}{C_2 \omega} - L_2 \omega\right)^2}}{\sqrt{\alpha^2 + \beta^2}}, \quad (81)$$

and

$$\Phi = \tan^{-1} \frac{\beta}{\alpha} - \tan^{-1} \left(\frac{1}{C_2 R_2 \omega} - \frac{L_2 \omega}{R_2} \right). \quad (82)$$

Here Φ is the angle between the primary current and the impressed electromotive force.

SECONDARY CURRENT.

The secondary current is similarly obtained by referring to the general equation (19), and substituting $f'''(t) = -E \omega^3 \cos \omega t$; $D^2 = -\omega^2$; $D^4 = \omega^4$. Making these substitutions, and multiplying numerator and denominator by D , we obtain

$$i_2 = \frac{D M E \omega \cos \omega t}{a D + \omega \beta}. \quad (83)$$

Operating upon the numerator by D , then multiplying both numerator and denominator by $a D - \omega \beta$, and again operating as indicated, we free the equation from the operator D , and obtain the final integral

$$i_2 = I_2 \sin \left(\omega t - 90^\circ + \tan^{-1} \frac{\beta}{\alpha} \right), \quad (84)$$

where α and β stand for the expressions given in (78) and (79), and

$$I_2 = \frac{M E \omega^3}{\sqrt{\alpha^2 + \beta^2}}. \quad (85)$$

These equations just obtained for the primary and secondary currents are the general equations for a transformer, subjected to an harmonic impressed electromotive force, when we have a condenser in each circuit, and make no assumption as to the absence of magnetic leakage, but neglect the change in coefficient of self-induction due to the presence of iron. Their complete discussion would be beyond the limits of the present paper. The generality of the equations may be modified by various limitations,—as, for instance, by the omission of one or both

condensers, and by the assumption of no magnetic leakage. The subject can be treated in the inverse order, and the more general obtained synthetically from the simpler cases, the results being the same as those obtained analytically. The identification of the results obtained for a certain case from the general solutions, and those obtained for the same case by a process of building up from simpler cases, is not always readily shown. Suffice it to illustrate in the case in which both primary and secondary condensers are omitted and there is no leak; that is, when

$$C_1 = \infty; C_2 = \infty; M^2 = L_1 L_2.$$

The theory of the transformer for this case has been synthetically developed by the writers,* and may be identified with the results obtained for this case from the general discussion in this paper.

The general relation between primary and secondary currents (81) and (85) is

$$I_2 = \frac{M \omega I_1}{\sqrt{R_2^2 + \left(\frac{1}{C_2} \omega - L_2 \omega\right)^2}}. \quad (86)$$

This expression is evidently in accordance with the law that the current in a circuit is equal to the impressed electromotive force divided by the impediment. For the particular case under discussion this becomes

$$I_2 = \frac{M \omega I_1}{\sqrt{R_2^2 + L_2^2 \omega^2}}.$$

The general value for the primary current in (81) reduces for the particular case to

$$I_1 = \frac{E \sqrt{R_2^2 + L_2^2 \omega^2}}{R_1 R_2 \sqrt{1 + \left(\frac{L_1 \omega}{R_1} + \frac{L_2 \omega}{R_2}\right)^2}}. \quad (87)$$

These results are the same as those obtained on page (340) in the series of articles just referred to.

The angular relation between the primary and secondary currents is seen by a comparison of (80) and (84). The secondary current lags behind the primary by an angle of 90° plus an angle

* "Theory of the Transformer." *Electrical World*, vol. xxxi., beginning No. 12, March, 1893.

whose tangent is $\frac{1}{C_2 R_2 \omega} - \frac{L_2 \omega}{R_2}$. If there is no condenser in the secondary, this lag is $-90^\circ - \tan^{-1} \frac{L_2 \omega}{R_2}$, which is in accordance with the well-known transformer diagram. A condenser in the secondary might reduce this angle to 90° or make it even less, as is seen from the equations, and may likewise be shown synthetically. The geometrical construction of transformer diagrams may be thus analytically established.

If we consider that there is no magnetic leakage and put $L_1 L_2 - M^2 = 0$, and that there are no condensers in circuit, the expression (78) and (79) for α and β become

$$\alpha = \omega^2 (R_1 L_1 + R_2 L_2),$$

and

$$\beta = -\omega^2 R_1 R_2.$$

Hence

$$\tan^{-1} \frac{\beta}{\alpha} = \tan^{-1} - \left(\frac{L_1 \omega}{R_1} + \frac{L_2 \omega}{R_2} \right),$$

and by (82),

$$\phi = \tan^{-1} - \left(\frac{L_1 \omega}{R_1} + \frac{L_2 \omega}{R_2} \right) + \tan^{-1} \frac{L_2 \omega}{R_2}.$$

This easily reduces to

$$\phi = \tan^{-1} \frac{-\frac{L_1 \omega}{R_1}}{1 + \frac{L_1 L_2 \omega^2}{R_1 R_2} + \frac{L_2^2 \omega^2}{R_2^2}} \quad (83)$$

which is identified with the result given on page 340 of the articles in the *Electrical World* referred to above.

Although the analytical expressions might be found by means of the general equations (16) and (19), when there is an harmonic impressed electromotive force, to cover all cases which arise when there are condensers present in the circuits of a transformer, yet it will be found that many problems will lend themselves to readier solution by the graphical methods in which diagrams are built up by synthetic processes. It is considered that the above examples, which identify the results independently obtained from differential equations with the diagrams made from other considerations, are sufficient to show that any diagram has its analytical equations, and any equations, properly derived from the harmonic law, have their corresponding geometrical interpretation.

MAKE AND BREAK WITH HARMONIC ELECTROMOTIVE FORCE.

In the discussion of the current flow in the primary and secondary of a transformer subjected to an harmonic electromotive force, the exponential terms which constitute the complementary function have been omitted from the equations, and the currents are simple harmonic functions of the time. These exponential terms modify the current for a short time after the make, but their effects rapidly diminish and become negligible after a fraction of a second. The exponential terms have been discussed in the earlier part of this paper, and the effects there described are to be superimposed upon the simple harmonic flow of current which would take place if they were not present. Whether these terms are oscillatory or not depends, as before, upon the relation between the various constants of the circuits. When the complementary function is oscillatory, the resultant current for a short time oscillates about its final sinusoidal form, its form depending upon the relation between the period of the impressed electromotive force and the natural period of the circuit, and upon the time of introduction of the electromotive force. The periods may be such that distinct beats are obtained. These oscillations are the same in nature as those which occur after the make of a single circuit containing resistance, self-induction and capacity,

CURRENT FLOW IN A SINGLE CIRCUIT.

The equations for a single circuit containing resistance, self-induction and capacity are directly derivable from those for a transformer by assuming that the secondary is removed. To find the values for α and β for this case, take out from (78) and (79) the factor $R_1 R_2 \omega^2$, and let $\frac{L_2 \omega}{R_2} = 0$; $\frac{M \omega}{R_2} = 0$; $\frac{1}{C_2 R_2 \omega} = 0$. For the primary circuit alone, we then obtain the values

$$\alpha = R_1 R_2 \omega^2; \beta = \left(\frac{L_1 \omega}{R_1} - \frac{1}{C_1 R_1 \omega} \right) R_1 R_2 \omega^2.$$

Substituting these values in (80), the expression for primary current becomes

$$i_1 = \frac{E}{\sqrt{R_1^2 + \left(\frac{1}{C_1 \omega} - L_2 \omega \right)^2}} \sin \left\{ \omega t + \tan^{-1} \left(\frac{1}{C_1 R_1 \omega} - \frac{L_1 \omega}{R_1} \right) \right\} \quad (89)$$

This is the value for the current at any time in a simple circuit containing resistance, self-induction and capacity when subjected to an harmonic electromotive force, and is fully discussed for general and particular cases in the writers' treatise on *Alternating Currents*.

CONCLUSION.

We have considered two mutually related circuits with constant coefficients of self-induction, thus not taking into consideration the changes in the coefficient of self-induction, which occur at high magnetization, when iron is present due to the hysteresis loss. The analytical work can only be rigorously correct when there is no iron, and must be looked upon as an approximation, when iron is present, which is justified when a high degree of magnetization is not reached. We have developed the expressions for the current flow in such circuits in general due to any impressed electromotive force, and have illustrated how they may be reduced to simpler forms for particular cases,—as for the case of an ordinary transformer and for a simple circuit. The limits of this paper make it impossible to enter into a full discussion of the analytical results obtained or to take up the many particular cases covered.

As there was no discussion on this, the following paper was then read.

EXPLANATION OF THE FERRANTI PHENOMENON.

BY DR. T. SAHULKA.

Of the Technical High School, Vienna. Austria.

In the paper I intend to read before you, I shall give a theoretical explanation of the *Ferranti* phenomenon, and communicate some results obtained by experiments.

If the primary of a converter is in connection with an alternating current generator, whilst the secondary is connected with a condenser, the capacity of which is not too great, then some phenomena can be seen, that are named the Ferranti phenomena. The ratio of transformation of the converter may be considerably increased; at the same time the primary current is a little smaller, and the primary potential difference a little greater than is the case when the condenser is disconnected from the converter. These phenomena were first observed in the Deptford Central Station, near London, when the secondary of a step-up converter, which transformed from 2,500 to 10,000 volts, was connected with a Ferranti concentric cable. A full explanation of these phenomena has not been given up to date, as far as I know. It can be proved, theoretically, that the cause of the *Ferranti* phenomenon is based on the magnetic leakage; that was also experimentally proved by me. Should all lines of force, induced by the primary, traverse all turns of the secondary, then the *Ferranti* phenomenon could not occur.

THEORETICAL EXPLANATION.

First Case.—We may firstly consider the case in which the secondary is not connected with a condenser, but with a resistance r_2 , having no capacity and self-induction. The primary potential difference may be $\Delta_1 \sin 2 \pi n t$ in which formula n

is the number of full periods per second. The ohmic resistance of the primary coil may be named R_1 , the total ohmic resistance of the secondary circuit R_2 ; the coefficients of self-induction may be named L_1 L_2 , the coefficient of mutual induction M . If c_1 c_2 are the instantaneous values of the primary and secondary current, then the equations of Maxwell must hold :

$$\left. \begin{aligned} \Delta_1 \sin 2 \pi n t &= R_1 c_1 + L_1 \frac{d c_1}{d t} + M \frac{d c_2}{d t} \\ 0 &= R_2 c_2 + L_2 \frac{d c_2}{d t} + M \frac{d c_1}{d t} \end{aligned} \right\} \quad (1)$$

Let :

$$p = 2 \pi n.$$

$$k = \frac{M p}{\sqrt{R_1^2 + p^2 L_1^2}}$$

We get according to the formulæ of Maxwell, for the maximum value of the secondary currents the expression :

$$C_2 = \frac{\Delta_1 k}{\sqrt{(R_2 + k^2 R_1)^2 + p^2 (L_2 - k^2 L_1)^2}} \quad (2)$$

The maximum difference of potential between the secondary terminals is :

$$\Delta_2 = C_2 r_2.$$

The ratio of transformation is :

$$u = \frac{\Delta_2}{\Delta_1} = \frac{k r_2}{\sqrt{(R_2 + k^2 R_1)^2 + p^2 (L_2 - k^2 L_1)^2}} \quad (3)$$

The value of R_1 is always very small and can be neglected. If the secondary is open or closed by a great resistance r_2 , then we can approximately substitute $r_2 = R_2$, as the ohmic resistance of the secondary coil is very small in comparison with r_2 . We get from the formulæ (2) and (3).

$$\begin{aligned} k &= \frac{M}{L_1} \\ u &= \frac{M}{L_1} \frac{r_2}{\sqrt{R_2^2 + p^2 \left(L_2 - \frac{M^2}{L_1} \right)^2}} \end{aligned} \quad (4)$$

If the converter is a very good one, that means, if there is no magnetic leakage at all, then we have

$$M^2 = L_1 L_2$$

and, therefore,

$$u = \frac{M r_2}{L R}.$$

The values of L_1 and L_2 are in this case in the ratio of the squares of the turns N_1 and N_2 of the primary and secondary coil. Therefore it follows :

$$u = \frac{N_2 r_2}{N_1 R_2}.$$

If r_2 is very great, or if the secondary is open, then we can substitute for r_2 : R_2 and get

$$u = \frac{N_2}{N_1}.$$

If, however, the condenser has a great magnetic leakage, then we have

$$M^2 < L_1 L_2.$$

In the formula 4 remains the second term in the denominator, therefore, we get:

$$u < \frac{M}{L_1}.$$

Besides we have in this case :

$$M < \sqrt{L_1 L_2} \text{ or } \frac{M}{L_1} < \sqrt{\frac{L_2}{L_1}},$$

therefore is the more

$$u < \frac{N_2}{N_1}.$$

If there is a great magnetic leakage in the converter, the ratio of transformation may be considerably smaller than the ratio of the number of turns.

Second Case.—The secondary of the converter may be connected with a condenser of capacity K . We have now to substitute in the formula (1) of Maxwell, for L_2 the value $L_2 - \frac{1}{p^2 K}$, as the condenser has the apparent negative coefficient

of self-induction : $\frac{1}{p^2 K}$

The formula for C_2 has to be changed in the same way, the formulæ for k undergoing no change. The value of R_2 is in this case only the ohmic resistance of the secondary coil, and is, therefore, very small, just like R_1 . We get the maximum difference of potential Δ_2 between the terminals of the secondary

by multiplying C_2 with the apparent resistance (impedance) of the condenser, that is to say, with $\frac{1}{pK}$. We have, therefore:

$$A_2 = \frac{A_1 k}{p K \sqrt{(R_2 + k^2 R_1)^2 + p^2 \left(L_2 - \frac{1}{p^2 K} - k^2 L_1 \right)^2}} \quad (5)$$

Neglecting $R_1 R_2$ and substituting for k its value, we get:

$$u = \frac{A_2}{A_1} = \frac{M}{L_1} \frac{1}{p^2 K \left(L_2 - \frac{M^2}{L_1} - \frac{1}{p^2 K} \right)}. \quad (6)$$

If there is no magnetic leakage in the converter, then we have to substitute:

$$\begin{aligned} M^2 &= L_1 L_2 \\ L_1 : L_2 &= N_1^2 : N_2^2. \end{aligned}$$

It follows:

$$u = \frac{N_2}{N_1}.$$

The ratio of transformation of a converter having no magnetic leakage remains the same, the secondary may be open, or connected with a great ohmic resistance, or connected with a condenser having a small capacity.

If, however, the converter has a great magnetic leakage, then in the formula (6) the difference $L_2 - \frac{M^2}{L_1}$ in the denominator is no more equal to zero. As there is a difference in the denominator, we can find suitable values of K , making the difference very small. In this case the ratio of transformation can be considerably increased, and depends upon K . Calculating the ratio of transformation from the formula (6), we must not forget, that in formula (5), the term $(R_2 + k^2 R_1)^2$ was neglected; that is only allowable if the second term has a considerably greater value.

If the ratio of transformation increases, then at the same time the phenomenon was observed, that the primary current decreases a little, and the primary potential difference increases a little, provided the alternator furnishes a constant electromotive force. That is caused by the increase of the impedance of the primary. If the secondary circuit is open, the primary coil has the impedance:

$$\sqrt{R_1^2 + p^2 L_1^2}.$$

If the secondary circuit is connected with a condenser, we have to substitute for $R_1 L_1$ other values $R_1' L_1'$, which have been calculated by Maxwell, but we have to substitute in these formulæ of Maxwell for L_2 the value :

$$L_2 - \frac{1}{p^2 K}.$$

Now we get

$$R_1' = R_1 + \frac{M^2 p^2 R_2}{R_2^2 + p^2 \left(L_2 - \frac{1}{p^2 K} \right)^2}.$$

$$L_1' = L_1 - \frac{M^2 p^2 \left(L_2 - \frac{1}{p^2 K} \right)}{R_2^2 + p^2 \left(L_2 - \frac{1}{p^2 K} \right)^2}.$$

$$R_1'^2 + p^2 L_1'^2 = (R_1^2 + p^2 L_1^2) + \frac{M^2 p^2 (M^2 p^2 + 2R_1 R_2 - 2p^2 L_1 L_2 + \frac{2L}{p^2 K})}{R_2^2 + p^2 \left(L_2 - \frac{1}{p^2 K} \right)^2}$$

The denominator of the second term in the last equation has always a positive value. In the numerator we find a difference. If K is small, then the term $\frac{2L}{p^2 K}$ has a great value, and, therefore, the numerator will be positive. In this case we get :

$$R_1'^2 + p^2 L_1'^2 > R_1^2 + p^2 L_1^2.$$

The increase of the impedance of the primary coil causes a decrease of C_1 and an increase of A_1 .

EXPERIMENTAL RESULTS.

The result of the calculation, that the Ferranti phenomenon is caused by magnetic leakage, was found in accordance with the following experiments. I designed for this purpose a special converter. The straight core consisted of about 2,000 varnished iron wires, having a length of 41 cm. and a thickness of 1 mm. The whole length was divided in two unequal parts, one quarter and three quarters of the length. Around the shorter part was wound a coil of copper wire having three layers, every layer consisting of 73 turns. Over this coil was wound another coil, having only one layer of 73 turns. In the same way there were wound around the longer part of the core, firstly, an inner coil,

consisting of three layers, each layer having $3.73 = 219$ turns, and then an outer coil having only one layer of 219 turns. The coils were well insulated. The copper wire was thin, as the converter was not designed to supply heavy currents, and as every experiment only lasted a short time. If the two coils, wound around the shorter part of the core, were connected in series and used as the primary circuit, then the magnetic leakage was very strong; the numbers of turns are in the ratio $292:876=1:3$. If, however, the two outer coils connected in series were taken as primary, and the two inner coils in series as the secondary circuit, then the magnetic leakage was small, the turns of the primary and secondary being equally distributed over the whole length of the core; in this second case the numbers of turns are in the same ratio as before $292:876 = 1:3$.

The alternate current used for the experiments was supplied by an electric central station. The current had 2,500 full periods per second, and a potential difference of about 105 volts. The primary of the above described converter was connected in series with a regulating resistance, in order to get the same effect as if the converter were connected immediately with an alternator. The potential difference A_1 between the terminals of the primary was measured with a Cardew voltmeter, the potential difference A_2 between the terminals of the secondary with a multicellular electrostatic voltmeter, requiring almost no current. The intensity of the primary current may be called C_1 , the ratio of transformation u .

First Experiment.—The coils of the converter were connected for great magnetic leakage. When the terminals of the secondary circuit were connected with the electrostatic voltmeter only, the following values were measured:

$$A_1 = 74, A_2 = 102 \text{ volts, } u = 1.38, C_1 = 7.6 \text{ amperes.}$$

If the terminals of the secondary were now connected with a condenser, having paraffined paper as dielectric and a capacity of 5.15 microfarad, then the values were changed into:

$$A_1 = 75.3, A_2 = 122.7, u = 1.63, C_1 = 7.5.$$

The ratio of transformation increased 18 per cent. It is certain that a condenser of a greater capacity would have caused a still greater increase of the ratio of transformation, corresponding with the observed effects caused by condensers of a smaller capacity; but I had no larger condensers at my disposal. We

cannot wonder that the ratio of transformation is much smaller than the ratio of turns, the magnetic leakage being very great.

Second Experiment.—The coils of the converter were connected for small magnetic leakage. If the secondary circuit was open, the values were :

$$A_1 = 55.6, A_2 = 150, u = 2.70, C_1 = 7.9.$$

By connecting the secondary terminals with the above mentioned condenser, the values were changed into :

$$A_1 = 56.6, A_2 = 154.9, u = 2.74, C_1 = 7.8.$$

In this case the ratio of transformation increased only by 1.5 per cent. The resistance connected in series with the primary circuit was in this second experiment not the same as in the first, otherwise the primary current would have been too strong.

Third Experiment.—The converter had great magnetic leakage. The potential difference between the terminals of the secondary was measured with a Cardew voltmeter requiring 0'2 ampere. When the condenser was disconnected there was found:

$$A_1 = 63.1, A_2 = 85, u = 1.35.$$

After inserting the condenser, the values changed into :

$$A_1 = 63.7, A_2 = 96, u = 1.51.$$

The increase of the ratio of transformation amounts in this experiment only to 11.9 per cent. The more the secondary would be loaded, the less would be the increase.

The results that I have obtained, either by theory or by experimental researches, show that the Ferranti phenomenon is caused by magnetic leakage.

FINAL MEETING, FRIDAY, AUGUST 25TH.

Section A was called to order at 10 A. M., by Secretary Kimball.

Professor MacFarlane was elected temporary chairman.

In the absence of the author the following paper (in French) was read by title.

MEASUREMENT OF THE ENERGY OF POLYPHASE CURRENTS.

BY A. BLONDEL, PARIS, FRANCE.

Ever since the appearance of the polyphasal currents, the electricians have, with right, tried to find a simple method of measurement, which is applicable to the determination of the electrical power consumed by a polyphase circuit or any current receiving apparatus.

But, strangely, at first complicated formulæ were arrived at by the aid of laborious demonstrations, while the simple formula which is used to-day, became almost self-evident.

I will here only give a general idea of this question, supposing any number of phases and of conductors, and you will see that the formulæ known to you are simply particular cases of the general formula, and that they are not capable of any further simplification.

GENERAL CASE: POLYPHASAL CURRENTS WITH n CONDUCTORS.

Let us consider n conductors AA' , BB' , CC' , ... terminating into n terminals A , B , C , of an apparatus, in which the external circuits can assume a more or less complicated form; these conductors, which I will call "principal conductors" are traversed by any number of independent currents, which may follow any law whatever.

Let, in any moment t , i_a , i_b , i_c ... signify the current intensities in each of the conductors, and v_a , v_b , v_c ... the potentials in the terminals A , B , C ,

The intensities are all counted in the same sense according to the arrows, and can be positive or negative.

The algebraic sum of all the currents in the n conductors is 0 at every instant:

$$\Sigma i_a = 0.$$

The energy absorbed during the time, dt , by each of the currents i_a, \dots is equal to the product of the quantity of electricity absorbed in that time, $i_a dt$, multiplied by the corresponding potential v_a . The energy of the n currents, in any moment, is therefore,

$$p = \Sigma i_a v_a. \quad (1)$$

Instead of the absolute potentials we can introduce the potential differences between the terminals A, B, C . . . and any common point m , having the potential v , according to the identity

$$\Sigma i_a v = v \Sigma i_a = 0,$$

by means of which we can write immediately:

$$p = \Sigma i_a (v_a - v). \quad (2)$$

Let us suppose we have to deal with alternating polyphase currents, then the intensities and potentials are all of periodical functions, say, of the same period T . The mean energy can be expressed by

$$P_m = \frac{1}{T} \int_0^T P \cdot dt = \Sigma \frac{1}{T} \int_0^T i_a (v_a - v) dt. \quad (3)$$

In order to measure this energy practically, it will be sufficient to determine, in the usual way, by means of a wattmeter or by the other methods known to the art, each one of these partial energies

$$\frac{1}{T} \int_0^T i_a (v_a - v) dt,$$

and to add the n values algebraically.

In all these measurements, the common point m must be chosen so that none of successively introduced connections changes the relative values of the potentials v_a, v_b, \dots and v , and the distribution of the currents.

This result can only be obtained if m is chosen in the system itself, or on a specially definite branch, according to one of the following two methods:

First. *Common Point M in the System Itself.*—If the measurements are made by means of an electrometer, by the method of Mr. Potier or similar ones, no new connection needs to be introduced between the point m and the terminals A, B, C, . . .

but an additional resistance is successively inserted in each of the principal conductors, capable of changing the distribution of the currents; in this case the symmetry must then be re-established by introducing equivalent resistances in all the conductors.

If, which is here preferable, a wattmeter with two coils is used, type Zipernowsky, then one of the currents i_a , in each measurement, is sent through the coil with coarse wire, while in the same time the coil with fine wire is placed between the corresponding terminal, A , and the chosen point, M . In order to avoid that this branch appreciably alters the potentials, it is sufficient to insert—as in simple alternating currents—a dead resistance, which is large enough to make the derived currents very small compared with those from which they are branched off (and in order that the difference of phase of the derived current is negligible).

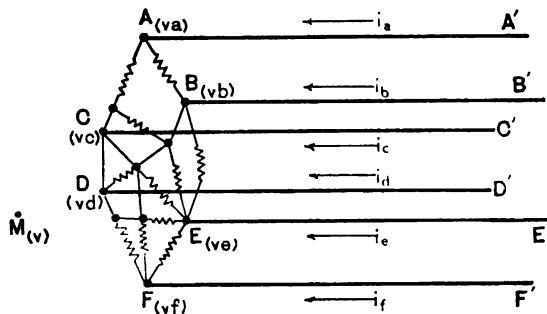

FIG. 1.

In order to reduce the number of measurements to $n - 1$, it is convenient to take as the common point one of the terminals of the apparatus itself, for instance, A . We have then:

$$p = (v_b - v_a) i_b + (v_c - v_a) i_c + \dots \quad (4)$$

an expression which could have been obtained directly by considering the conductor AA' as the return lead of the other $(n - 1)$ conductors.

Second. Common Point M in the Centre of a Star-like Branch System.—Such a system is obtained in establishing n circuits AM, BM, CM, \dots (Fig. 1), between the terminals A, B, C, \dots and any external point M , each of these n circuits being formed by a considerable dead resistance R .

If the n measurements are made by means of the electrometer, no new connection between M and the terminals need

be made, and the only source of error will be the one which I have given above.

If, on the other hand, the wattmeter is used, it will be sufficient to insert the fine wire coil successively into every branch of the star-like system, taking care that the chosen resistance, R , is sufficiently large, and inserting, if necessary, in every branch a coil equal to that of the wattmeter.

This second method is, nevertheless, much more complicated than the first one, and I only mentioned it on account of its theoretical interest, and on account of the very symmetrical form which it points to give to the energy. Indeed, the currents in the n branches, have for their instantaneous values $\frac{v_a - v}{R}$, $\frac{v_b - v}{R}$,, and since their algebraic sum in the point m is 0, we have,

$$\Sigma (v_a - v_0) = 0, \text{ from which } v_0 = \frac{1}{n} \Sigma v_a.$$

The energy can, therefore, be expressed by

$$p = \Sigma i_a \left(v_a - \frac{1}{n} \Sigma v_a \right). \quad (5)$$

In order to simplify the measurements, we can always imagine an instrument which is capable of giving the mean value of the energy by one single reading. It is sufficient for this purpose to construct a wattmeter containing n or $(n - 1)$ independent pairs of coils (not having appreciable mutual induction), and to fix all the movable coils to a common axis, the torsional moment of which can be determined by the usual method.

APPLICATION TO CURRENTS WITH THREE CONDUCTORS.

The formulæ for the energy of three-phase currents, which have recently appeared, and which are based upon certain suppositions as to the form of the circuit (Fig. 2), are but particular cases of the general formula (2).

In fact, if we reduce the number of conductors to three, formula (5) becomes:

$$p = i_a \left(v_a - \frac{v_a + v_b + v_c}{3} \right) + i_b \left(v_b - \frac{v_a + v_b + v_c}{3} \right) + i_c \left(v_c - \frac{v_a + v_b + v_c}{3} \right), \quad (6)$$

an expression, which has not before been given; if, in the same,

we let $e_\alpha, e_\beta, e_\gamma$, be the potential differences between every two of the principal conductors: $e_\alpha = v_a - v_c$; $e_\beta = v_b - v_c$; $e_\gamma = v_c - v_a$; we can write:

$$p = \frac{1}{3} [i_a (e_\alpha - e_\gamma) + i_b (e_\beta - e_\alpha) + i_c (e_\gamma - e_\beta)], \quad (7)$$

a formula, which was originally given by Mr. Goerges, and which is evidently more complicated than the one from which it is deduced.

We can transform (7) to the following formula, and receive, with Mr. Aron:

$$p = \frac{1}{3} [e_\alpha (i_a - i_b) + e_\beta (i_b - i_c) + e_\gamma (i_c - i_a)].$$

On the other hand, the expression (4) can be transformed to

$$p = i_b (v_b - v_a) + i_c (v_c - v_a), \quad (8)$$

a formula which was recently given by Mr. Behn-Eschenberg, and afterwards by Mr. Aron.

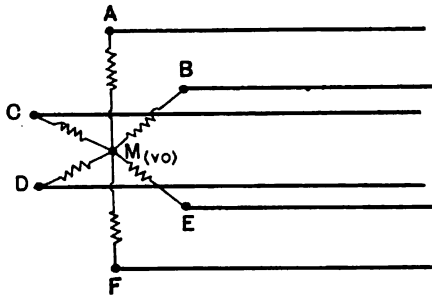

FIG. 2.

The above deduction is much more general than any other given so far, and can equally well, be applied to two-phase currents with three conductors.

PRACTICAL CONCLUSIONS.

In practice we must try to reduce the measurement of the energy to the least number of readings possible, and to bring the number of parts of the measuring instruments to a minimum.

Wattmeters and recording instruments must, therefore, be exclusively based upon formula (8), and the whole process finally is the same as measuring the total energy of two independent alternating currents which have only one common return conductor.

It is, therefore, nothing special in such a measurement, and it is sufficient to put a wattmeter or a recording instrument in each one of the two circuits and to add the readings.

In regard to the recording instruments, there is a great simplification and at the same time a great economy in uniting the two apparatus into one single one, as for the first time Mr. Aron has done (although his instrument has the fault of establishing a certain mutual induction between the two circuits), and as it is done now by the watt-meter of E. Thomson.

As to the watt-meters, the economy realized would be smaller, and it is otherwise advantageous to employ two separate wattmeters, in order to compare, at every instant, the charges of the two circuits. However, in most cases we will find it very convenient to unite the two bobbins in one single apparatus by placing the two movable bobbins on one common axis, and by putting the two fixed bobbins one above the other perpendicularly in order to avoid the mutual induction. This Mr. Kennelly has done very ingeniously in his "*differential*" wattmeter. This latter instrument would be very convenient for the purposes set forth in this paper, in changing simply the direction of one of the currents, thus making an "*additional*" wattmeter from the "*differential*."

Finally, I need but remark that the measurement of the energy of polyphasal currents differs in nothing from that of ordinary alternating currents.

The paper entitled
THE EXTENDED USE OF THE NAME RESISTANCE
IN ALTERNATE CURRENT PROBLEMS.

BY PROF. W. E. AYRTON.

was read by title, the author being obliged to be present at another session.

SECTION B.

FIRST MEETING, TUESDAY, AUGUST 22D, 1893.

The meeting was called to order at 10.30 A.M. by Professor Charles R. Cross, of Boston, Mass., who stated that the first business in order was the appointment of a committee to nominate permanent officers of the section. These officers to be: a permanent chairman of the section, a permanent secretary, and a third member, who shall, with the others, constitute an executive committee for the consideration of all subjects that appropriately come before such committee.

On motion of Lieutenant Reber, the chairman was empowered to appoint such committee to nominate the three officers mentioned. The following committee was appointed: Professor S. P. Thompson, of London, Dr. Louis Duncan, of Baltimore, and Mr. W. F. C. Hasson, of San Francisco.

This committee reported the following nominations for permanent officers who were then unanimously elected: Chairman, Professor Charles R. Cross, of Boston, Mass.; Secretary, Lieutenant Samuel Reber, U. S. A.; additional member of Executive Committee, Professor A. E. Dolbear, of Tufts College, Mass.

THE CHAIRMAN:—We will now proceed to the reading of the papers. The first paper on our list is by William H. Preece, F.R.S. The paper is entitled "Signalling through Space by Means of Electro-magnetic Vibration."

MR. PREECE said: Mr. President, Ladies and Gentlemen, When I was invited to prepare a paper for this congress, I happened most fortunately, for myself, to be engaged in an investigation that was nearly complete, and I was only too glad to secure such a splendid opportunity to make public the facts that I had so far found out, so I cheerfully and readily accepted the task of bringing the subject of transmission of signals through space before you here to-day.

SIGNALLING THROUGH SPACE BY MEANS OF ELECTRO-MAGNETIC VIBRATIONS.

BY. W. H. PREECE, F.R.S.

President of the Institution of Electrical Engineers, England.

In the year 1842, Henry showed how the disruptive discharge of a Leyden jar in an upper chamber of his house magnetized needles in a cellar 30 feet below.

The introduction of that beautifully sensitive instrument, the telephone, in 1877, made us acquainted with disturbances and influences between neighboring wires at a distance which surprised every one. Morse signals, cross-talk, strange noises impaired the efficiency of telephone working.

In 1884, telegrams sent to Bradford (England), in Morse characters, from the General Post Office, London, through a gutta-percha covered copper wire in an underground iron pipe, buried in the street, were read upon an open telephone circuit consisting of an iron wire carried on poles on the housetops 80 feet away.

In 1885, Mr. Edison showed how it was possible to communicate with a moving train by utilizing the electrostatic influence between a circuit erected upon the poles on the side of a railway and a telephone circuit carried by the train.

In the same year, I made many experiments to determine whether the effects observed in England were due to electro-magnetic induction, and were quite independent of the earth; and also to find out how far the distance between the wires could be extended before this influence ceased to be evident.

With our ordinary telegraph working currents the region of disturbance reached a distance of 3,000 feet; while the effects

were detected on parallel lines of telegraph, 10½ miles apart, between Durham and Darlington. Even between the East and the West Coasts at the Border, a distance of 40 miles, currents produced at Newcastle on the Jedburgh line were distinctly heard at Gretna on a parallel line. These latter results, in the North of England, were vitiated by the presence of a large network of railway and other telegraphs between the two places, and as they may not have been due solely to direct electro-magnetic induction through space, but to electro-static effects between neighboring wires as well, I took a district in the West of England, between Gloucester and Bristol, along the banks of the River Severn, where for a length of 14 miles, and at an average distance apart of 4.5 miles, no intermediate disturbing conductors existed between the pole lines. The valley of the Mersey, and several other localities in England where no disturbing elements existed, were similarly investigated.

It is necessary at the outset to point out that if we have two parallel conductors separated from each other by a finite space, and each forming part of a separate and distinct circuit, either wholly metallic or partly completed by the earth, and called respectively the *primary* and the *secondary* circuit, we may obtain currents in the secondary circuit either by conduction or by induction, and we may classify them into those due to—

1. Earth currents.
2. Electro-static induction.
3. Electro-magnetic induction.

It is very important to eliminate (1), which is a case of conduction, from (2) and (3), which are cases of induction.

1.—EARTH CURRENTS.

When a linear conductor dips at each end into the earth, with which it makes a good connection, and voltage is impressed upon it by any means, the resulting return current would probably flow through the earth in a straight line between these two points if the conduction of the earth were perfect; but as the earth, *per se*, is a very poor conductor indeed (and probably is a conductor only because it is moist), lines of current-flow spread about symmetrically in a way that recalls the figure of a magnetic field. These diffused return earth conduction currents are evident at great distances.

These lines of current-flow are very easily traceable by means of exploring earth plates or rods. The primary current is best produced by alternating currents of such a frequency as to excite a distinct musical note on a telephone, and if these currents rise and fall, periodically and automatically, they produce an unmistakable wail. If they are made and broken by a Morse key they can transmit readable signals. The secondary circuit, which contains the receiving telephone, is completed in the case of the earth by driving two rods into the ground, or, in the case of water, by plates dipping into the water at a distance of from 5 to 10 yards apart.

In this way the Town Moor, near Newcastle, the sands and the land about Lavernock and Penarth on the coast of South Wales, the water of the Bristol Channel, the towns of Liverpool and Leeds, and London itself, have been thoroughly explored; and it has been proved that the distance to which these lines of

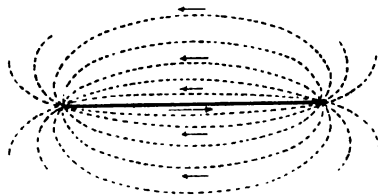

FIG. 1.

flow can be detected depends upon the intensity of the primary current flowing, on the area of the surfaces in contact with the earth, on the resistance of the portion of the earth utilized, and on the dryness of the season. In London the currents working the City and South London Electric Railway affect recording galvanometers at Greenwich $4\frac{1}{2}$ miles away, and a diagram of the train service on the railway can be recorded in any part of the metropolitan area.

The distance in sea water is not so extensive, for the latter is a better conductor than earth; still, with primary currents of 15 amperes, effects have been traced to one-third of a mile.

In all cases where disturbances have been created by electric tramways they have been shown to be greater in summer than in winter.

It is very necessary to be able to distinguish or separate these earth currents from currents due to induction, for they are very

apt to give false effects and to lead to erroneous conclusions. This is easily done, if the instrument be sensitive enough, by making the primary current continuous when the earth current also becomes continuous, while induction currents are momentary and are observed only during the rapid rise or fall of the inducing cause.

2.—ELECTROSTATIC INDUCTION.

When a body, *A* (Fig. 2), is electrified by any means and isolated in a dielectric, it establishes an electric field about it.

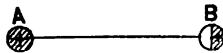

FIG. 2.

Lines of electric force are projected from it in every direction ; and if in the direction of any of these lines of force there is placed another similar body, *B*, it is also electrified by induction. If *B* be placed in connection with earth or with a condenser or with any large body, then the charge of the same sign as *A* is conveyed away, and *B* (Fig. 3) remains electrified in the opposite sense to *A*, and to the same amount. *A* and *B* are seats of elec-

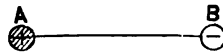

FIG. 3.

tric force. They form a stress, and are the ends of a line of force. The dielectric between them is displaced or polarized electrically. It is in a state of strain and remains so as long as *A* remains charged, but if *A* be discharged or have its charge reversed or varied, then similar changes occur in *B* and through the dielectric separating them.

If *A* (Fig. 4) be a flat disc electrified positively and be placed

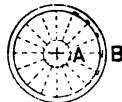

FIG. 4.

inside a ring, *B*, then the ring becomes the termination of lines of electric force, and the sum of their terminal negative charges is equal to the whole positive charge of *A*. *A* may, in each of the above cases, be the section of a continuous wire or conductor forming part of a complete circuit. The charge on *A* may be

due to the electric force of a primary current, while in the secondary conductor, B, the displaced charge in flowing to earth establishes a momentary current whose direction and duration depends on the current of A, and on its rate of variation.

The strained state of the dielectric and the charges on A and B remain quiescent so long as the current flows steadily; but if the

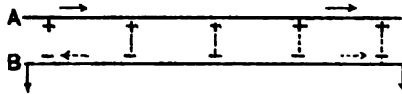

FIG. 5.—DURING CHANGE.

primary current ceases or falls, then we have secondary currents in each conductor, as shown by the arrows, and flowing until equilibrium is restored.

The secondary currents, due to discharge, flow in opposite directions at each end, and there is always some intermediate zero point.

It is thus easy in long circuits, by observing their direction, to

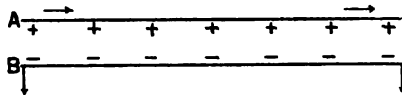

FIG. 6.—STEADY CURRENT.

differentiate currents of induction due to electric displacement from those due to electro-magnetic disturbance.

The dielectric plays just as important a part in the electrical operations that occur as do the conductors. Its molecular disturbance cannot be neglected. It is subject to strain and variations of displacement in one direction, while it is permeated by a wave of energy in another direction, viz., in the direction

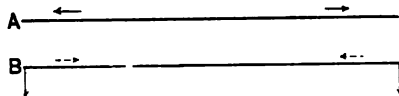

FIG. 7.—DURING DISCHARGE.

of the primary current. In fact, it is a question much discussed at the present day whether the prime action in all current effects is not this wave or flux of energy passing longitudinally through the dielectric in the direction of its length, and that nothing whatever passes through the conductors, which are mere passive agents in the matter, wasting energy but not transmitting it.

There are two views of the formation and support of a current. The one following Faraday regards it as the continuous discharge of the contiguous charged molecules of the conductor, the action originating in and being propagated uniformly throughout the conductor. The dielectric plays only a secondary part. The other derived from Maxwell by Poynting regards a current as the consequence of a propagation of a wave of electrical energy through the dielectric in the direction of the line and which reaches the wire from the exterior. The conductor plays a secondary part, it simply dissipates the energy conveyed by the dielectric. The current is set up on the surface and it penetrates the interior comparatively slowly, while its distribution in any given sectional area of the conductor is not uniform.

The truth lies probably in a combination of each view. The dielectric is as much an essential agent in the action as the conductor, and in each plane, perpendicular to the current, the charge and discharge of contiguous molecules, the formation of an electric field, the formation of a magnetic field, the flow of energy across this plane and parallel to the conductor, its dissipation as heat in the conductor are all simultaneous and self-dependent, and equally concerned in the final result.

In a complete metallic loop, like a telephone circuit, the energy is propagated in the dielectric between the wires; it is dissipated in the wires, there are longitudinal waves propagated through the dielectric parallel to the wires, and there are other circular electro-magnetic waves emanating from each conductor as a centre and flowing as a resultant in planes perpendicular to the wires. Thus there are lines of electric force, lines of magnetic force, and lines of energy flow. The first determine displacement, and are controlled by electrostatic capacity; the second determine electro-magnetic disturbance, and are controlled by inductance; the third determine transformation of energy, and are controlled by resistance. Time enters into the consideration of the longitudinal flow of the energy through the system, of the electro-magnetic disturbance through the dielectric at right angles to this flow, of the rise and fall of the current at each point of the circuit, of the character of the current, whether continuous or alternating, and, if alternating, of the frequency of the complete alternations.

The effects of electrostatic induction do not play an important part in the enquiry immediately before us, but they are of great

consequence in considering questions of speed of signalling in submarine cables and clearness of speech in long distance telephony.

3.—ELECTRO-MAGNETIC INDUCTION.

Magnetic force is that which produces or tends to produce polarization in magnetizable matter, viz., iron, nickel and cobalt, and electro-magnetic disturbance in non-magnetizable matter and the ether. It excites lines of magnetic force and becomes a stress. An electric current in a conductor is a seat of magnetic force. It establishes in its neighborhood a magnetic field.

The lines of force (Fig. 8) in such a field are equivalent to circles in a plane perpendicular to the direction of the current, which, during the rise of the current in A, flow outwards, and during the fall of the current, flow inwards, like the waves on the surface of smooth water when a stone is dropped into it, but

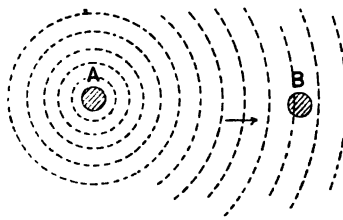

FIG. 8.

moving with the speed of light. Thus any other linear conductor, B, placed in this field parallel to A, is cut at right angles to itself by these lines of force—in one direction as the current rises, and in the other direction as the current falls. The projection of lines of magnetic force through a linear conductor in a direction perpendicular to its length excites electric force in that conductor; and, if the conductor be continuous and form part of a circuit, it establishes voltage, and, therefore, a current in this secondary circuit. Now, the strength of this secondary current (c_2), depends on the strength of the primary current (c_1); on the rate at which it rises or falls; $\left(\frac{d c}{d t}\right)$, on the resistance of the secondary circuit (r_2); on the distance which separates the two circuits (d) and on the length of the inductive system (l). The direction of the secondary current everywhere is reverse to that of the primary during its rise and in the same direction during its fall.

If the two circuits are separate and independent, this action between them is called mutual-induction; but if B be a part of the same circuit, A , it is called self-induction. The amount of induction is dependent also on the magnetic conditions present in the conductors and in the space between them. This is measurable in its own unit (which it is proposed to call "henry"), is called *inductance*, and is usually indicated by L or M , according as the question dealt with is self- or mutual-induction.

EXPERIMENTAL INVESTIGATION.

Since 1885 I have had a vast number of experiments made to thresh out the laws and conditions that determine the distance at which these magnetic disturbances can be usefully evident. The instrument used to receive these signals has been generally the telephone, but many absolute measurements have been made with a very sensitive reflecting galvanometer. The judgment required to determine the relative intensity of sound in a telephone is a very variable and uncertain agent, even though many observers be utilized and the same experimenters perform with the same apparatus. But this does not apply to the observation of the limiting audible intensity of signals. The point where sound ceases is obtained with concordant and satisfactory results when the mean judgment of several observers using the same telephone is made use of. I never use less than three observers, and sometimes have employed as many as seven. By this means, we observe by what I call the *average normal ear*.

I.—To prove that the effects were due to Electro-magnetic Induction.

Conductors of copper wire insulated with gutta-percha were formed into quarter mile squares (Fig. 9) and laid on a level plain at a distance of a quarter of a mile apart.

Arrangements were made for sending vibratory or alternating currents which could be broken into Morse signals by means of a telegraph key. Telephones were used as receivers, which transformed these signals into buzzing dots and dashes.

On closing the circuit in one square and sending signals, conversation could be readily held between the two operators by means of the Morse code. Now, obviously, earth conduction could play no part in this transmission of signals, for the squares were insulated throughout from the earth.

Next, in order to ascertain to what extent, if any, electrostatic effects were observable, one pole of the battery used was put to earth, and the further end of each square was disconnected (Fig. 10.)

Now, by this arrangement, the mean electric force of one square was doubled, as compared with the former experiment, where the circuit was completed, but no effect was observed in the second square, either in the receiving telephone or with the reflecting galvanometer. The squares were even superposed at

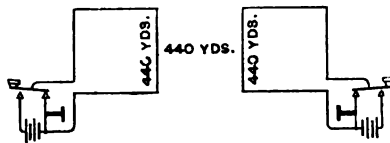

FIG. 9.

a distance of only 15 feet apart, the upper one being suspended on poles, and the lower one lying on the ground, but without any results. Hence, the effects observed in this experiment were clearly due to electro-magnetic induction.

II.—To prove that the effects increased directly with the strength of the primary current used and diminished with the resistance of the secondary current.

a. Two quarter mile squares of insulated wire were opposed to one another, and the distances between the front faces varied

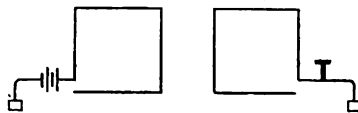

FIG. 10.

from 8 yards to 192. Currents of 1 and 2 amperes respectively were sent into one square, and the induced effect in the second square with 2 amperes was invariably twice that with 1 ampere. The measurements were made with a reflecting galvanometer.

b. Open wires were placed parallel to one another, and a mile apart horizontally (Fig. 11). The primary circuit was two miles long. The other, the secondary circuit, was divided into two equal one-mile lengths. With a primary current of .22 ampere, the vibrations were just audible in a telephone fixed to either of

the single mile lengths of the secondary, the total resistance in the latter circuit being 85 ohms. With a similar current (.22 ampere) in the primary, and the secondaries joined into a two-mile length, the same limit of audibility was reached when the resistance in the secondary was doubled, that is, it was raised to 170 ohms. Next, the current in the primary was doubled or increased to .44 ampere; and with a one-mile secondary the total resistance had to be doubled in order to reach the same limit. Finally, when the current in the primary was raised to .88 ampere—four times the original figure—then the same limit was reached when the resistance was quadrupled.

III.—To find how the effects varied with the length of the inductive system and with the distance separating them.

The law for variation of length and distance is very complicated and depends wholly on the form of the circuit and its various reactions. It may be briefly summarized as follows, but the experiments upon which these conclusions are drawn will be given as an appendix, together with the equations developed from them.

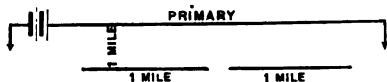

FIG. 11.

Let l = length and d = distance apart of two conductors assumed equal and similar, then

a. With two infinitely long straight wires, it varies inversely as d alone.

b. With one infinitely long straight wire and a wire of finite length, it varies as $\frac{l}{d}$.

c. With one infinitely long straight wire opposed to a rectangle, the law becomes.

$$l \left(\frac{l}{d} - \frac{l}{D} \right)$$

where D is the distance from the face to the back of the rectangle.

d. Where the rectangle is replaced by a square, the above formula becomes

$$\frac{l^2}{d(1+d)}$$

e. With a rectilinear wire of finite length l opposed to a square, the length of the former being equal to the face of the latter, it varies as

$$\frac{l}{d}$$

f. With two squares of equal dimensions opposed to one another (Fig. 13), the effect varies, where l is great compared with d , as

$$\frac{l}{\sqrt{d}}$$

but when d exceeds half l , it varies as

$$\frac{l}{d}$$

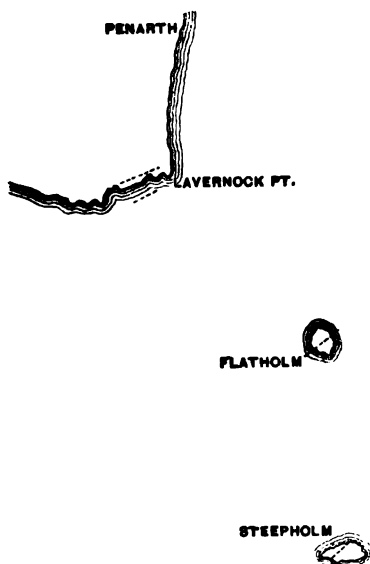

FIG. 12.

NOTE.—With cases *c*, *d*, *e* and *f*, if d became very great, the effect would diminish and ultimately disappear, owing to the opposing current in the back of the square having practically the same influence as that in the front. When d is very great, the effects due to a and a_1 may be neglected.

g. With two rectilinear wires of equal length if the effect of the magnetic waves due to the return current through the earth

be neglected, then when l is great compared with d , it varies as

$$\frac{l}{d}$$

but when d is great compared with l , it varies as

$$\frac{l^2}{d^2}$$

The complete formula for the aerial portion of the circuit is as follows:—

Let c_1 = current through primary,
 q_2 = quantity induced in secondary,
 r_2 = resistance of secondary,
 l = length of either wire,
 d = distance between wires,
 then m being a constant in c. g. s. units,

$$q^2 = \frac{c_1}{r_2} \frac{\sqrt{l^2 + d^2} - d}{d} \times m.$$



FIG. 18.

The complete formula must of course allow for the reverse effect of the return circuit through the earth. I hope later to obtain sufficient data on which to base such a formula.

The value of m , obtained from a series of experiments on two parallel squares of wire, 1,200 yards in length, and five yards apart, was found to be .003.

h. The difference in water as compared with air is not very marked. In certain experiments on the Conway Estuary, which were considered reliable and which appear in Table I., it was about 6 per cent. more in the air than in water. The result was probably due to the magnetic waves being degraded into electrical currents in traversing the conducting sea water.

4.—PRACTICAL EXPERIMENTS.

The Bristol Channel proved a very convenient locality to test the practicability of communicating across a distance of three and five miles without any intermediate conductors. Two islands, the Flat Holm and the Steep Holm, lie off Penarth and Lavernock Point, near Cardiff, the former having a lighthouse upon it. On

the shore two copper wires, weighing 400 lbs. per mile, combined in one circuit, were suspended on poles for a distance of 1,267 yards, the circuit being completed by the earth. On the sands at low water mark, 600 yards from this primary circuit and parallel to it, two ordinary gutta-percha covered copper wires and one bare copper wire were laid down, their ends being buried in the ground by means of bars driven in the sand.

One of the gutta-percha wires was lashed to an iron wire to represent a cable. These wires were periodically covered by the tide which rises here at spring to 33 feet. On the Flat Holm, 3.1 miles away, another gutta-percha covered copper wire was laid for a length of 600 yards.

There was also a small steam launch having on board several lengths of gutta-percha covered wire. One end of such a wire, half a mile long, was attached to a small buoy, which acted as a kind of float to the end, keeping the wire suspended near the surface of the water as it was paid out while the launch slowly steamed ahead against the tide. Such a wire was paid out and picked up in several positions between the primary circuit and the islands.

The apparatus used on shore was a two H. P. portable Marshall's steam engine, working a Pike and Harris's alternator, sending 192 complete alternations per second with a voltage of 150 and of any desirable strength up to a maximum of 15 amperes. These alternating currents were broken up into Morse signals by a suitable key. The signals received on the secondary circuits were read on a pair of telephones—the same instruments being used for all the experiments.

The object of the experiments was not only to test the practicability of signalling between the shore and the lighthouse, but to differentiate the effects due to earth conduction from those due to electro-magnetic induction, and to determine the effects in water.

I have already alluded to the way in which the lines of current flow were mapped out. It was possible to trace without any difficulty the region where they ceased to be perceptible as earth currents and where they commenced to be solely due to electro-magnetic waves. This was found by allowing the paid-out cables, suspended near the surface of the water, to sink. Near the shore no difference was perceptible, whether the cable was near the surface or lying on the bottom, but a point was reached,

just over a mile away, where all sounds ceased as the cable sank, but were recovered again when the cable came to the surface.

The total absence of sound in the submerged cable rather surprised me, and it leads to the conclusion, either that the electro-magnetic waves of energy are dissipated in the sea water, which is a conductor, or else that they are reflected away from the surface of the water like rays of light.

Experiments on the Conway Estuary showing the relative transparency of air and water to these electro-magnetic waves, tend to support the latter deduction, for if much waste of energy took place in the water, the difference would be more marked; it was only six per cent. As it is, we have ample evidence that the electro-magnetic waves are transmitted to considerable distances through water, though how far remains to be found.

There was no difficulty in communicating between the shore and Flat Holm. Messages were read. Mr. Gavey, who was making the experiment on the island, wrote me, "There was then somewhat a lengthened pause, due to a slight derangement of the machinery on the mainland, but at 2 p. m. I heard clearly and distinctly the following, 'Here Haskayne' (one of his assistants) 'with a message from Mr. Preece for Mr. Gavey.'" I was in London that day. "Then followed the announcement of the sad and sudden death of Mr. Graves, which cast a gloom over the success of the experiment. It seemed an extraordinary fact, that the first readable message transmitted for such a distance by such means should announce the death of the head of the Technical Department."

The distance between the two places was 3.1 miles. The attempt to speak between Lavernock and Steep Holm was not so successful. The distance was 5.35 miles, but though signals were perceptible, conversation was impossible. There was distinct evidence of sound, but it was impossible to differentiate the sounds into Morse signals. We were just on the limit of audibility, and we were using our maximum available power. If either line had been longer, or the primary currents stronger, we should have spoken as was done at Flat Holm.

The fact indicated by the formula for parallel wires that the limiting distance increases directly with the square of the length of the circuits, has a very important bearing on the practical results of these experiments, for it shows that if we can make the length of the two lines long enough, it would be easy to

communicate across a river or a channel. Of course, as previously pointed out, the formula does not take into account the effects of the reverse magnetic waves generated by the return current through the earth, and at present no data exist on which a satisfactory calculation can be based ; but for example, there is little doubt that two wires, 10 miles long, could signal through a distance of 10 miles with ease.

Although communication across space has thus been proved to be practical in certain conditions, those conditions do not exist in the cases of isolated lighthouses and lightships, cases which it was specially desired to provide for. The length of the secondary must be considerable, and for good effects at least equal to the distance separating the two conductors. Moreover, the apparatus to be used on each circuit is cumbrous and costly, and it may be more economical to lay an ordinary submarine cable.

Still, communication is possible even between England and France, across the Channel, and it may happen that between islands where the channels are rough and rugged, the bottom rocky, and the tides fierce, the system may be financially practical. It is, however, in time of war that it may become useful. It is possible to communicate with a beleagured city either from the sea or on the land, or between armies separated by rivers, or even by enemies.

A use to which these electro-magnetic disturbances can be applied is to indicate to ships their contiguity to lighthouses and land falls. Experiments are being made in this direction by Mr. Stevenson of the Northern Lights Commission on the coast of Scotland, but no results have yet been published. He proposes to submerge a cable on a given fathom line through which special automatic distinguishing signals are being sent, so that a ship approaching or crossing this line can pick up these signals on board and learn her true position.

I have also pointed out that as these waves are transmitted by the ether they are independent of day or night, of fog or snow or rain, and, therefore, if by any means a lighthouse can flash its indicating signals by electro-magnetic disturbances through space, ships could find out their positions in spite of darkness and of weather. Fog would lose one of its terrors, and electricity would become a great life-saving agency.

APPENDIX.

I.—EXPERIMENTS TO DETERMINE THE ELECTRO-MAGNETIC INDUCTION, BOTH IN WATER AND AIR, BETWEEN A RECTANGLE AND A FINITE LINE OF LENGTH EQUAL TO THE FACE OF THE RECTANGLE.—JUNE, JULY, 1893.

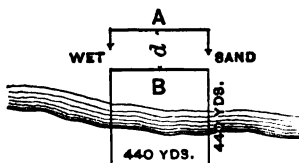

FIG. 14.

Currents were sent through the rectilinear circuit, A, by means of a suitable key, and the induced effect on the rectangle was observed on a carefully adjusted reflecting galvanometer.

EXPERIMENT WITH CONDUCTORS COVERED WITH SEA WATER.

<i>d.</i> yards.	Relative values of <i>d.</i>	Current through A (amps.).	Discharge deflection from B.	Equivalent in micro- coulombs.	Remarks.
100	1	2.00	16	.024	18 feet water over A.
200	2	"	8	.012	
300	3	"	5½	.008	
400	4	"	4	.006	
800	8	"	2	.003	

EXPERIMENT WITH CONDUCTORS IN AIR.

<i>d.</i> yards.	Relative values of <i>d.</i>	Current through A (amps.).	Discharge deflection from B.	Equivalent in micro- coulombs.	Remarks.
100	1	2.00	17	.026	Low water.
200	2	"	8½	.013	
300	3	"	5½	.008	
400	4	"	4	.006	
800	8	"	1½	.0023	

II.—EXPERIMENTS TO DETERMINE THE ELECTRO-MAGNETIC INDUCTION BETWEEN TWO RECTANGLES OF EQUAL DIMENSIONS.

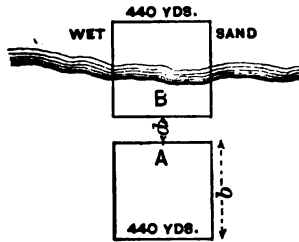

FIG. 15.

<i>l.</i>	<i>d.</i>	Relative values of <i>s.</i>	Current through A. (amps.)	Discharge deflection from B.	Equivalent in micro-coulombs.	Variation of deflection by formula $\frac{40}{\sqrt{d}}$	Remarks.
yards.	yards.						
440	8	1	2	40	.059	40.0	When current was reduced to 1 ampere the induced discharge was halved.
"	16	2	"	28½	.042	28.3	
"	24	3	"	23	.034	23.1	
"	32	4	"	19½	.029	20.0	
"	64	8	"	11½	.017	14.1	
"	96	12	"	8	.012	11.5	
"	192	24	"	4½	.007	8	

III.—EXPERIMENT WITH A RECTILINEAR WIRE FOUR TIMES THE LENGTH OF THE FACE OF THE RECTANGLE,

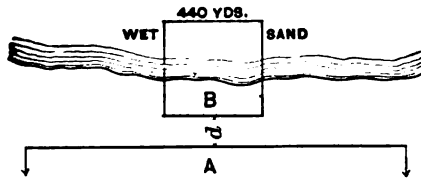

FIG. 16.

<i>d.</i>	Current through A (amps.)	Discharge deflection from B.	Equivalent in micro-coulombs.
192	2	20	.030

DISCUSSION.

THE CHAIRMAN:—The paper of Mr. Preece is now open for discussion. The paper is very suggestive in many points—theoretical as well as practical. I hope some of the gentlemen who are conversant with the subject in either or both of these ways, will favor us with some remarks.

MR. THOMAS D. LOCKWOOD, of Boston, Mass.:—I would like to ask Mr. Preece first, whether the parallel lines on the main land and on the island were provided with earth or water plates. That is to say, was the line on the Lavernock land a closed circuit, was it closed through an earth plate or was it closed through plates through water, or was it a metallic circuit?

MR. PREECE:—The earth.

MR. LOCKWOOD:—There are, I believe, three aspects of conditions in which the subject so ably brought before the Congress by Mr. Preece may be considered. But, before speaking of any of these aspects and conditions, I wish to express in the most hearty and cordial terms, the pleasure, and at the same time the instruction, that I for one, have experienced, in hearing Mr. Preece's paper and my thanks for the happy expressions and illustrations, for the able way in which he has given us a transcript of the paper; and for the way in which, without any formality, he has made us acquainted with the experiment, their results and the conclusions he has drawn from them.

It is not the first time, by any means, that the subject has engrossed the attention of electricians. There have been three separate ways, according to my understanding, in which the matter has been experimented with. We have heard, for example, of electrical communications taking place through the upper air by conduction, or at least, the action is supposed to be by conduction.

We have also been somewhat acquainted with electrical communications which have taken place through the medium of sea water. Heretofore, that has been supposed to be conduction also. And third, there have been electrical communications, as many of us know, as Mr. Preece himself intimates, between fixed points and moving vehicles. That has occurred, I believe, through the intermediation of both electrostatic and magnetic induction. It is right, therefore, for us to know, as indeed the speaker wishes us to know, that experiments have been made in these subjects; and at first sight, or at first thought, a title such as this to which we have been treated sounds to those who have not had any experience in such matters as being rather of a mythical order. Those of us who were brought up in the hard school of the telegraphic service were accustomed to believe that by wires only was it possible to send intelligence electrically. I for one, would say it was a very hard wrench to me indeed, to get any knowledge about that phenomenon of electrical generation and transmission which has always retained the name given

to it by the master himself: Induction. The line of consideration which Mr. Preece has chosen, is indeed, a trend in the direction of certain inventions which have been brought to our notice from time to time. But it is one step ahead. It is rather a singular circumstance that in the early days of telegraphy, (and it is recorded in one of the first books ever published on electro-magnetic telegraphy by Mr. Alfred Vail,) a number of experiments were made by Morse and his assistants, Mr. Vail and Mr. Rogers, in the Susquehanna river, which experiments were very much like those which have been detailed to us this morning. A long line was placed along the river side and terminal plates were placed in the river, and another line was placed along the bank on the other side. The only instruments used were Morse's relay, key and battery, the battery being on both sides. There was one rule which Mr. Morse said he had found out by his experience there, and that was: suppose this long straight line to be the banks of the river, (indicating on black board) and supposing the two short lines to be the telegraph lines, and the cross line to be between the plates, the length of the land lines should be very considerable longer than the lines across the river, through the water. Mr. Morse in his reports to Congress says that the signals were very clear; but for reasons that could not be disputed, namely, those stated by Mr. Preece, commercial reasons, the thing was not proceeded with.

A little later, about 1853, a countryman of Mr. Preece and a countryman of my own, a Mr. Dering, who was in the service of the Bank of England, took out an English patent, not for the thing I have shown there, but for the two lines on the two banks of the river, and naked wires laid in the river between the two plates. He also reports good service, but he didn't have the five independent observers with him, and we must, therefore, take his result, I apprehend, with a grain of salt.

A Mr. Lindsay, a celebrity of Dundee, a man who bobs up periodically and regularly, who is always put out by the *Dundee Advertiser*, as one who has done these things forty or fifty years ago, was the next man to experiment in this line. He also took out a patent, but all he did was to repeat Mr. Morse's experiments, and dispense with Mr. Dering's naked wire. From that time to the present there has not been a want of experimenters who have dabbled in that kind of work, and who have been ridiculed and have got in to print, as men who might have done something, or always did something, but who didn't quite reach success. It was correctly stated by Mr. Preece that the introduction of that wonderful instrument, the telephone, has made things possible, which, with an instrument of coarser grain, would be impossible; or, at all events, utterly impracticable.

Mr. Preece pointed out that at the present time in England, a great whirlpool of agitation is taking place by reason of

discharging the trolley currents into the earth. He remarks that they are as much troubled as we are. For myself, living in this country, I prefer to say, as we were. We are not very much troubled with that kind of thing now. Our experience leads us to believe that not only conduction, but electromagnetic induction bears its part in this disturbance. A very great deal of that depends on the way the electric railway is built, overhead and underground. And a very great deal more depends in the way in which the telephone line is built overhead and underground.

If it were possible to have two neutrally inductive electrical circuits, one belonging to the railway and one to the telephone, there would, I think, be very little trouble.

We find one thing in our streets which, as a rule, the English cities and towns do not have, namely, trees. The telephone lines are largely in parallelism with the trolley lines overhead, and though the main part of the disturbing current reaches the telephone circuits through the earth, a large portion also reaches them by way of the leaves of trees which touch the two circuits in common.

The subject now before the section is not altogether new even with the employment of the telephone. To some of us it is not new, and it is not new to Mr. Preece. When he was over here in 1884, I remember hearing, with great pleasure, a discussion of a paper given before the AMERICAN INSTITUTE OF ELECTRICAL ENGINEERS at Philadelphia, comprising a communication by Mr. Bear, who thought that he had been able to send through an un-insulated wire through the earth.

Mr. Preece was so good as to give us an account of his earlier experiments between the Isles of Wight and Man.

The present paper, indeed, is a splendid supplement to that; he has told us that it is impossible to use an ordinary Morse instrument to telegraph through water. He has found it was impossible to use a telephone, articulate or conversational; he has also found out that for success we should use a telephone as a telegraphic receiving instrument, using strong currents for transmitting, and using a vibratory reed, and a key which splits the musical note, into the signals of the telegraphic code. I have no doubt that his success, now reported, will lead him to still greater achievements later, concerning which he will inform us.

Now, I doubt for myself, whether the experiments which are made, are fully as conclusive as he appears to think they are, and that the means of communication between the land and the island is absolutely due to electromagnetic induction. But, granting that in part it is due to these, I should still think that the conductive power of sea water has its share in the transmission. However, I will say, I have not had the time to completely consider the subject, and, perhaps, upon reflection I shall have to take it back.

As to ships, it is not worth while for the owners to

have their ships supplied with special appliances for this work ; but between ships and light-houses and the main land, and between the main land and some special island ; in cases where the lines are broken, and where there is no immediate means of repairing them, I think we shall very likely find great use for such methods of transmission.

I don't think it is ever going to be of large commercial utilization for commercial transmission, even with the aid that the telephone gives it ; first, because it is cheaper in the end, as a rule, to lay a cable ; secondly, because if everything is fitted with the appliances for work, I think it will be difficult when a ship or light-house receives the message, to find out whether it is for that special ship or light-house. There would be the difficulty already mentioned in sending call signals, because there will, I think, have to be a special education on the part of the ships and light-houses to receive those messages before they are sent ; but to close my remarks, which I fear have been somewhat desultory, I wish to remark this, that on the Lehigh Valley, it is true as has been told, that an experiment has been made between moving cars and the stations. I don't think that they are carried on now, I don't think that they were found worth while. Mr. Wiley Smith, of Kansas City, was the first man who proposed that thing, and Mr. Edison took it up and made it practicable. But Mr. Edison's powers did not make it of commercial value, for this reason, that the average electrician has only one haven of rest, namely, the railroad and steamers, and does not want, when he is on these, as a general thing, to telegraph to anybody, and does not want to be telegraphed to.

PROF. ANDREW JAMIESON, of Glasgow, Scotland :—Mr. Chairman, I simply wish to ask Mr. Preece a question, more especially in regard to what has been tried in Scotland in order to communicate with a ship, and possibly in a region of danger. What is the longest distance, Mr. Preece, between the two insulated conductors in sea water at which you will be able to communicate ?

MR. PREECE :—The distance of communication between the two places may be equal to the length of the two wires.

PROF. JAMIESON :—Suppose this was a dangerous coast, such as Mr. Stevenson, the engineer in the light-house in Scotland had, have you tried, or do you know of any record of any experiment whereby human beings on board the ship have been able to communicate directly with the shore ?

MR. PREECE :—No, sir.

PROF. JAMIESON :—Has Mr. Stevenson done so yet ?

MR. PREECE :—No.

PROF. JAMIESON :—If this is an iron ship, as most ships are now, then have you any idea what would be the maximum distance ?

MR. PREECE :—None ; I might answer Prof. Jamieson at once

by saying that the result of the experiment is to show that the effect is only to be detected when the distance across is equal to the length of the shorter circuit, so the distance in this case would be the length of the ship. I should not expect a ship to get communication from a greater distance than its own length.

MR. A. W. HEAVISIDE:—Mr. Chairman, I wish to supplement Mr. Preece's paper with an account of an experiment that I made in the North of England, by which communication in a telephonic way was had between the bottom of a large colliery and the surface of the land. At the bottom of a pit, sixty fathoms deep, there were two ways, each three-quarters of a mile long. I could not get between the points by means of a metallic conductor; I used a microphone. I went on the surface of the colliery and laid out triangular lines of wire three-quarters of a mile on each side being over and parallel with the underground line. To our great joy telephonic speech was perfectly clear; it, therefore, follows that it is quite possible to make an arrangement of that kind underneath pits, so that in cases of disaster, if we had telephones placed at proper intervals and the wire was properly strengthened by iron covering, or in some other way to make it stand the fall of stones and so forth, these communications could be had from the pit up to the surface.

DR. CHARLES E. EMERY, of New York:—Mr. Chairman, I desire to call attention to the fact that there are two different principles involved in these several discussions which will be readily seen by most of those present. It is quite familiar in telegraphing across a stream, when the conductors on the two sides are much longer than the distance across, that it is a mere case of divided currents. A part of the current goes back through the earth, and some of it crosses and returns on the other conductor; thus we get in a very ordinary way the signals by a direct transfer of currents. There is no electro-magnetism or induction about it. The case that has been brought up by Mr. Preece of sending messages across a stream is a simple matter, in fact, it was taken advantage of in 1862 during the war, when we cut the lines and tried to cut off communication down the river, but the telegraph operators were smart enough to have two lines on two sides and kept up the communication.

MR. WEGAN:—In the Chesapeake Bay in Maryland, the dredging for oysters goes on up and down the bay for a distance of a 150 to 200 miles, and, of course, no cable could lay in such a place. It was necessary to communicate between certain points. Now, when the matter came up, and in view of these experiments, I suggested that they erect lines of the kind under discussion. Unfortunately the company met with financial disaster, or the experiment would very likely have been tried.

PROF. WYMAN:—In regard to the action of the current on that wire when it is on the surface or when it is sunk below, I should like to ask if the sea water surrounding the wire

does not act as a sort of shield in turning away the electromagnetic waves?

MR. PREECE:—I mentioned that in one experiment an insulated wire or a bare wire, whether it was covered or not, no perceptible difference could be seen, so it does not act as a shield.

MR. HERMAN LEMP, of Lynn, Mass.:—Mr. Preece, in your experiments, how high above ground was the wire strung on the shore?

MR. PREECE:—Twenty feet.

MR. LEMP:—Would not a more efficient arrangement be obtained if the wire was strung very much higher, supported on masts, towers, or held by captive balloons?

It seems to me that the current returning through the ground must, in a certain measure counteract the waves emitted by the current in the air line. This feature would be even more marked with the launch, in which case the salt water must undoubtedly form a very good return, in fact a return very close to the cable. Mr. Preece pointed out that the signals failed when the cable was allowed to sink in the water.

The most efficient shape that can be given to an induction coil or loop, is a perfect circle, or next to it a square. Such coils produce the strongest field for a given length of conductor, or emit the largest number of electromagnetic waves. I believe, therefore, that by arranging the wires receiving and transmitting, so as to form a loop resembling a square or triangle, in place of an oblong rectangle, as used in the experiment, signals would have been transmitted a greater distance and with less original energy on the shore. This is in fact borne out by the remarks of Mr. Heaviside, illustrating an experiment made in a colliery. A triangle, as used in that experiment, permitted a powerful field to be established, and not only were they able to transmit musical sounds, but even articulate speech was transmitted.

THE CHAIRMAN:—That perhaps had better wait and be answered in the general summary, which we hope Mr. Preece will give when this discussion is concluded.

Are there any further remarks to be made? If not, there is one point which occurred to me while Mr. Preece was reading his paper, which is of a theoretical rather than of a practical nature with regard to the loss of energy by reflection of the electro-magnetic wave. I suppose one might find by placing a wire underneath the water in a certain position, that the wave is totally reflected.

If there are no further remarks the discussion of this subject will be closed. And we shall be very glad to hear from Mr. Preece in regard to the matters to which his attention has been specially called.

MR. PREECE:—There really does not remain much for me to answer, because I have, perhaps rather irregularly, answered many of the questions as they were put to me. But I would

say, first, that if I had read the paper as it is printed I should have infallibly laid in the dust that old ghost of earth current and its effects, which Mr. Lockwood and some of the speakers have referred to. As I intended, the real purpose of the paper was to discuss the causes of electric energy, and I had hoped the discussions might have been confined to that. Now I may say this, there is no difficulty in this case knowing that the effect is not due to earth currents; first, because as I told you, by probing we limit the area of the earth currents.

I answered the question about water acting as a shield, but I cannot answer the question as to the influence of the height of the conductor. I don't believe myself that it has any influence whatever. If we find that the earth and water and air are the same as regards the transmission, I don't think whether the wire was below the water or up above in a balloon, that there would be any difference in the effect upon the island. As far as the suggestion of the Chairman is concerned, I think this question of reflection deserves further study. It has only recently been experimented upon. It was in the last series of experiments before I left. The last experiment was made on the day I left and I received the result of it on my arrival. I certainly shall pursue the subject and at the next congress I may bring out some other results.

THE CHAIRMAN:—Owing to the temporary absence of Dr. Lindeck and Professor Ayrton, the second and third papers on the printed programme will be postponed, and the next paper by Dr. Silvanus P. Thompson, F.R.S., on "Ocean Telephony" will now be read.

OCEAN TELEPHONY.

BY SILVANUS P. THOMPSON, D.SC., F.R.S.

I.—INTRODUCTORY.

It is contrary to the scientific spirit of progress to admit that any art or application of science can stand still, or that any of its developments are final. To bridge the ocean by an electric telegraph was a mighty achievement. To speak through a wire the audible syllables of language was a marvel. To accelerate telegraphic transmission by automatic devices until a speed of even 500 words per minute was attained was a bewildering accomplishment. But with the attainment of these three tremendous strides, finality has not been reached. The ocean cable of to day is practically unchanged from what it was thirty years ago. It speaks only with the still slow signals of the mirror galvanometer, or of the siphon recorder. Six or eight words per minute slowly spelled out are the usual limits of working of an Atlantic cable. The spoken telephonic word, and the rapid automatic telegraphic message are too nimble for it. For such rapid signalling it is dumb. That a submarine cable clad in its coating of gutta-percha would retard the rate of signalling was predicted by Faraday, and verified when the first long cable was laid. Many have been the subsequent devices to increase the speed of signalling by the use of condensers and the like. They have all been devices to be applied either at the transmitting, or at the sending end, or at both. Arrangements of condensers and resistances so combined as to act as an artificial cable, imitating the retardations of an actual cable, have been found indispensable adjuncts for balancing the properties of the cable in order

to adapt it for duplex working. Varley proposed, many years ago, another device, namely, to introduce at each end an inductive shunt; that is to say, to apply as a shunt 'a wire possessing both resistance and self-induction. But in spite of the use of condensers, of artificial cables, and of inductive shunts, the retardation of the long submarine cable has proved hitherto insuperable save for slow signals. In the sending of each signal the gutta-percha coating becomes charged, and this charge must be, as it were, swept out before the next signal can be sent. Retardation triumphs over the telephone and the automatic rapid telegraph.

And yet no reasonable electrician can doubt for a moment that ocean telephony must come, or that the resources of science are equal to the solution of the problem. It is because the author thinks that he has found the way to the solution that he ventures to place on record the ideas which have been growing in his mind for three years past, together with some of the evidence by which their soundness may be tested.

If the solution at which he has arrived seems strange to the ordinary telegraph electrician or cable engineer, it is because that solution has dawned upon him, out of a different domain of science, namely, from the study of alternate current phenomena. If the solution he now propounds seems impracticable to cable engineers accustomed to the old type of cable that has persisted now for 30 years, he would reply that it is the business of the engineer to make it practicable. If the business of the world demands a new type of cable then the engineer must be found who can manufacture and lay it. Seeing that such a cable, once laid, will (if the author's views are correct) perform the work at a rate that would at present require, say, 10 ordinary cables to perform, there is a very powerful inducement to the engineer to find a practicable way of realizing that which theory indicates as the submarine cable of the future.

II.—DEVICES TO NEUTRALIZE THE RETARDING EFFECTS OF CAPACITY IN SUBMARINE CABLES.

The retardation of signalling, which is found in submarine cables, is due to the capacity of the cable, and this capacity is distributed fairly uniformly along the cable. Owing to this circumstance, all attempts made hitherto to annul or compensate its

operation by means of devices situated at the *ends* of the cable, have met with very limited success. Whereas the ordinary speed of signalling through an Atlantic cable is about eight words or so per minute, it would be quite possible to send 400 words per minute through a line of the same resistance, but destitute of capacity.

The only effective way to annul the retarding effects of a *distributed* capacity is to apply a *distributed* remedy; that is to say, abandoning the idea of compensating it by devices placed at the ends of the cable, means must be sought for applying compensating devices *distributively* along the length of the cable, either at intervals or continuously.

It is well known that the effects of electro-magnetic induction are, in a sense, reciprocal to those of capacity. The most familiar modern example is that of the opposite operation of self-induction and of capacity on the phase of an alternate current, the one tending to produce a lag, the other a lead, in the phase of the current relatively to the electromotive force. It is

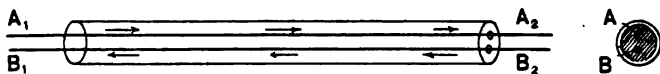

obvious that if electrostatic capacity can be used to correct the effects of electro-magnetic induction, conversely it will be possible to use electro-magnetic induction to correct the retarding effects of electrostatic capacity.

There are two main modes of action of electro-magnetic induction, namely, *mutual induction*, from wire to wire (with or without an iron core intervening, and sometimes called electro-dynamic induction), and *self-induction* when the current in a wire reacts inductively on itself. Both are known to be due to the setting-up, by currents, of magnetic fields in their neighborhood.

There are a very large number of ways in which, theoretically, the end may be obtained of compensating the effect of the distributed capacity by means of distributive electro-magnetic induction. It will suffice here to consider two simple cases, and for the sake of simplicity it will be supposed that each is applied to the case of a cable containing two insulated wires for the out-

going and returning currents. Such a cable may be represented in Fig. 1, where $\Delta \Delta$ is the out-going wire or "line," and $B B$ the incoming wire or return. In the subsequent figures the sheathing will not be specifically indicated.

CASE I.—Use of Self-Induction Devices Distributively.

In this case a series of self-induction coils of sufficiently high resistance and sufficiently great inductivity are placed across at intervals from the Δ conductor to the B conductor. In order the

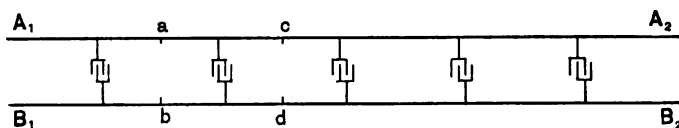

FIG. 2.

better to follow the action it will be convenient to represent the distributed capacity as in Fig. 2. Here the two conductors $A_1 A_2, B_1 B_2$, are drawn as though each in itself was devoid of capacity, but that a capacity was given to them in a distributive way by arranging a number of condensers along at intervals, each condenser having one coating joined to the Δ line, and the other coating joined to the B line.

Suppose the signalling to take place from the left hand end, and that a wave of current is being thrown into the circuit at A_1

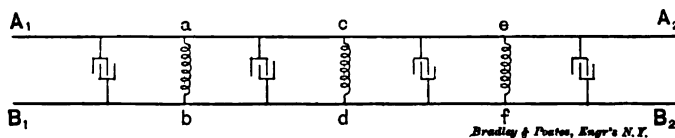

FIG. 3.

by a transmitting apparatus joined to $A_1 B_1$. Were there no capacity or inductivity in the line $A_1 A_2$, the wave would travel simply along without retardation. But the presence of capacity changes all this. When the potential at A_1 is rising the potential at some point along the line a would not rise simultaneously, because of the capacity in the intervening part of the conductor. The potential at a cannot rise to its proper value until the condenser between A_1 and a has received its charge. Similarly, the potential at c does not rise as soon as at a , because of the action

of the capacity between c and a . Again, when the potential at A_1 is falling, it will not also fall at a or at c simultaneously, because the condensers in between tend to keep up the potential, and take time to empty themselves. Whenever the potential at any part of the line is rising, some of the current tends to flow into the condenser at that part, with the result that the rise of potential in that part is delayed, while the current beyond that part is for the moment smaller than the current that is coming up to the part. Further, when the potential at any part is falling there is a tendency for current to flow out of the condenser at that part, and thereby keep up the potential a little later; so that at that moment the current flowing away from the part in question is greater than that flowing towards the part. If nothing is done to compensate this action, the effect would be that virtually all the wave thrown into the cable at A_1 would be taken up in playing into and out of the successive condensers, and so only an insignificant and much-retarded fraction of it would reach the end A_2 .

Now suppose that self-induction coils are placed across the cable at the proper intervals, as in Fig. 3. The operation of the coils in compensating the retarding effect of capacity is as follows:—When the potential at a rises, current begins to flow through the self-inductive coil $a b$, and this current tends, by the well-known inertia-like action of self-induction, to go on after the applied electromotive force producing it has begun to diminish, or has even stopped or reversed. Hence the current in the self-induction coil $a b$ will attain its maximum value at a time after the potential at a has begun to fall. It will by that very circumstance, as a consequence of the electromagnetic momentum, tend to make the potential at a fall *sooner* than it otherwise would do. Hence the respective actions of the self-induction coil and of the condenser are of opposite kinds. One tends to cause the changes of potential in the line to occur *later* than they should occur: the other tends to cause the changes of potential to occur *sooner* than they otherwise would occur. Hence their action tends to compensate one another if applied at the same place. But the capacity of a line or cable is not at one place; it is distributed all along it. Therefore it is essential that the compensating devices should also be placed all along it, at sufficiently frequent intervals. It is well known that Varley employed an inductive shunt *at each end* of a cable; but this is not capable of com-

compensating the capacity, except within, at most, a few score miles of the ends. The coil *a b* (Fig. 3) may be looked upon as compensating the capacity on both sides of it to a certain distance; the coil *c d* as compensating the capacity on both sides of it; and so forth. If all these compensators are properly ranged along the cable, then the total retarding effect of the distributed capacity will be practically annulled. The currents that run in and out of the transmitting end will be greater in quantity than those that are delivered in and out at the distant end; the difference being of course accounted for by the currents that flow across through the compensating coils. It will be seen that by the use of these devices, a certain fraction of the currents that are sent in at the transmitting end is, so to speak, used up on the way to pass through the compensating coils and by their action prevent the retardation of the rest of the currents that are flowing down the line. To put the matter tersely, the compensators act as leaks across from the *A* line to the *B* line, which by their inductive action sweep out the accumulating charges that would otherwise retard the signals. Some calculations on the magnitude of the currents that must thus flow across in the compensating coils have been made by the author, and some others for him by Dr. Sumpner. From these it appears that taking as a working basis the actual facts about cables as they are, and assuming a twin wire cable having a capacity of $\frac{1}{2}$ microfarad, and a resistance of 10 ohms, for a mile length, also assuming that compensating coils are placed across at every 10 miles, if such coils have a coefficient of self-induction of 100 henrys and a resistance of 3,000 ohms each (its time-constant being then about $\frac{1}{100}$ ths of a second), the rise and fall of current in each section will, with currents of the ordinary telephonic periodicity, be practically instantaneous in each section during the very small fraction of a second that the impulse lasts; and the value of the current from section to section will be practically determined solely by the shunting action of the successive compensators. Now, as telephonic currents may be shunted down to an extraordinary degree of tenuity, and yet be perceptible, it is evident that there are great possibilities opened out by this method of using the shunted portions of the current to neutralize the retardation.

The cable so constructed of two wires with compensating devices shunted across at intervals of 10, 20, or it may be 500

miles apart, will be represented diagrammatically by Fig. 4. The practical problem then remains how to provide compensators having a sufficiently great time-constant without their constituting unwieldy enlargements of the cable. This is a very simple matter of construction. The author has tried several species of devices, some of them resembling elongated "hedgehog" transformers made very long and thin, and wound with

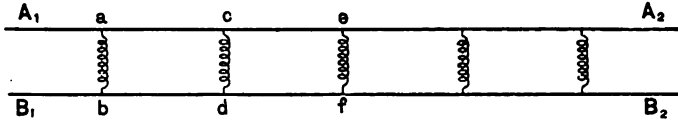

FIG. 4.

one coil only of fine wire; others consisting of "shell" transformers elongated into a very long, narrow loop; others again consisting of simple iron wire, straight or looped, or of wire over-wound with a layer of iron wire. The self-induction, for example, of a one millimetre iron wire, over-wound with a layer of iron wire three millimetres deep, is roughly about 0.1 henry

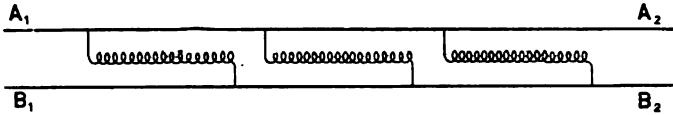

FIG. 5.

per kilometre; and its resistance is 144 ohms. One point in favor of the use of loaded straight wires as self-induction devices is the circumstance that the compensator need not join two adjacent points in the two conductors within the cable, but may lie across as in Fig. 5. This construction, which is specially suitable for cables of moderate length, resolves itself into a three-

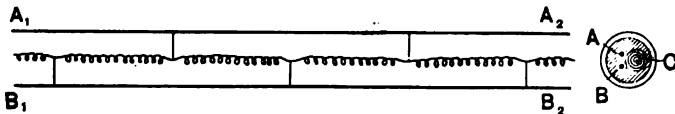

FIG. 6.

wire cable, of which one wire is loaded in some way to give it self-induction and resistance, and is connected at intervals alternately to the other two, as in Fig. 6.

As stated above, however, not only by self-induction but by mutual induction, the retarding effects of capacity may be neutralized.

CASE 2.—Use of Mutual Induction Devices Distributively.

In this case the cable is considered in sections, each of which is in inductive relation with those on each side of it; and again there are many possible varieties included. One example is as follows:—Let the two conductors along the cable be each divided into a number of equal lengths, and let the parts be joined together by mutual-induction coils, that is to say, by in-

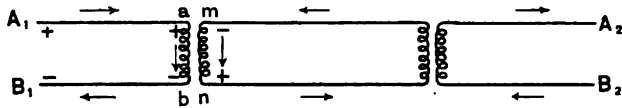

FIG. 7.

duction coils with two windings each. Though the exigencies of cable-laying will necessitate some very different shape of coil or device as an organ of mutual induction, we may assume these induction coils to be of the familiar form of an iron core surrounded by the two windings. The cable so made up of sections will be indicated by Fig. 7.

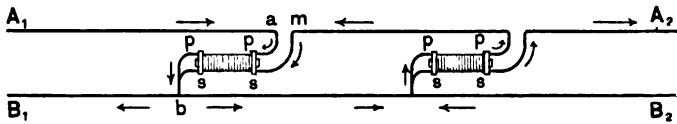

FIG. 8.

In this figure it is indicated that the coils are so connected that in the A line when the current is increasing and flowing toward *a*, the inductive action will be causing a current in the next section, which will be at the same instant increasing, but flowing, so far as the A line is concerned, in the opposite sense, so that while the potential of the point *a* is rising, that of the point *m*

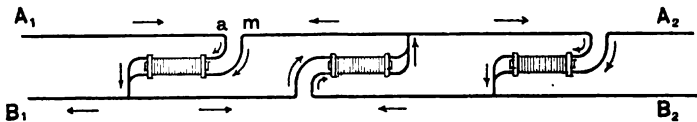

FIG. 9.

is falling. The consequence will be that the currents required to sweep out any accumulated charges due to capacity will not have to travel (as in ordinary cables) all the way from the ends of the cable, but need only travel short distances, never more than the length of half a section. Hence, if a cable 2,000 miles long is cut up into 25 sections of 80 miles each, there should be

no more retardation than on an ordinary cable 40 miles in length. It is not needful that both the lines should actually be divided: a virtual division into sections is effected in Fig. 8, where the B line is actually continuous. In this figure *pp* is the primary, and *ss* the secondary (or *vice versa*) of the mutual induction coil. Or the arrangement may be alternated, as in Fig. 9.

Or again, if three conductors are employed—of which one may be the sheathing—the sectioning and use of mutual induction may be accomplished, as shown in Fig. 10.

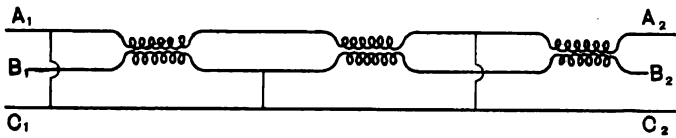

FIG. 10.

Here, again, as remarked above, the kind of induction coil which naturally suggests itself as suitable for the purpose in question is something of elongated shape, such as a very elongated loop “shell” transformer, or the “cable” transformer which was suggested for electric lighting purposes by Messrs. Siemens and Halske some years ago. Or, as the author suggested in 1891, by using a mutual induction between the wires of the cables

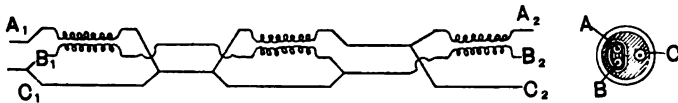

FIG. 11.

themselves by merely enwrapping them, as they lie side by side, with iron. So that the cable once more becomes an arrangement of three parallel wires, of which two are specially brought into mutual inductive relations to one another, and are joined up at intervals, as indicated in Fig. 11.

Lastly, it is, as is well known, possible to have mutual induction between two wires that do not form part of closed circuits, as in the phonopore of Mr. Langdon Davies.

III.—EVIDENCE AS TO THE PRACTICABILITY OF USING INDUCTION DEVICES DISTRIBUTIVELY TO COMPENSATE RETARDATION.

With the facts already known that the Varley shunt does indeed operate at the ends of a cable to compensate in some measure the effects of capacity near those ends, and that on long land lines the speed of signalling can be increased by inserting a translator in the middle, or even by a mere leak at some intermediate point, it is remarkable that no one should have suggested hitherto the very simple solutions now proposed. Perhaps the reason is to be found in the intense horror with which all good telegraph engineers regard the idea of having a fault on their line. Deliberately to insert, as the author proposes, a series of faults, as shunts across the cable from the going wire to the return wire, will, to many of them, appear sheer madness. The shunts are not mere faults, however. They are bridges possessing considerable resistance, and, what is more to the point, considerable self-induction. They are not leakages, through the insulation to the sheath, of an unknown amount, and one liable to increase by corrosion; they are as fixed and determinate as the resistance of the cable itself. Telegraph engineers have long known in general the virtues of an inductive shunt. In the third volume of the *Journal of the Society of Telegraph Engineers*, 1874, Mr. G. K. Winter describes the use of inductive resistances in cable signalling, such shunts being used at the ends of the cables, as Varley had previously used them. The idea of using such Varley shunts distributively along the cable appears to have been vaguely in the mind of no less eminent a telegraph engineer than the late Mr. Willoughby Smith, who, in 1879, read a paper on the working of long submarine cables to the Society of Telegraph Engineers. In this paper, after recounting some experiments made with Varley shunts—or what he seemed to think such—he adds: “I was under the impression that by a judicious distribution of electromagnets on subterranean lines greater speed might be obtained.” But he seems to have been deterred from following out the idea by finding that the solid core electromagnets which he was using failed to operate favorably; and he even declared that such minute currents as were used in cable signalling were “totally inadequate to produce perceptible electro-magnetic induction effects.” We now know from telephonic experience that this is not so; even the

minutest telephonic currents being perceived, simply because they can produce sensible electro-magnetic effects.

Other electricians have proposed to use shunts containing electromagnets from line to earth for various purposes. Amongst them Mr. Lockwood and Mr. Edison. The latter in his patent, No. 135,531, applies such shunts to overcome the static charge on lines. The author, in 1884, proposed to apply such shunts to enable him to introduce a battery current into a telephone line without diverting the working telephonic currents. Again, it has been found in telephone work that a telephone receiver placed across from line to earth, as a shunt or bridge, does not prevent another receiver further down the line from receiving its proper current. This bridge method of arranging telephonic instruments has for years been used in the British Postal Telegraph service. In 1890 a most suggestive communication was made at the Detroit Convention of the American Association by Mr. J. J. Carty on "Bridging Bells," in which he described arrangements of way-lines in which the electromagnets of the bells instead of being inserted in the lines (where their impedance would prevent telephonic talk), were set as bridges or shunts from line to earth. He found* a way-line, with eight such shunts upon it at eight intermediate stations, to transmit speech *better* than it did with only two stations. In this case the coils used had resistances of 1,000 ohms, as measured on the Wheatstone bridge; but, with a magneto-generator giving an alternate current the impedance was about 10,000 ohms. Again, when in 1891 the London-Paris telephone line was constructed by Mr. Preece, with a special cable about 20 miles in length from Dover to Calais in the middle of it, the circuit being metallically closed, it was found that the talking from London to Paris was in no way interfered with when telephonic receivers were bridged across the circuit at the two ends of the cable. In fact, such bridging rather improved the working of the line. It is, therefore, reasonable to suppose that by systematizing the arrangements, of which more or less imperfect glimpses are afforded in these instances, and by providing a cable with inductive shunts at proper intervals all along so as to balance the capacity from point to point, in a distributive manner, the longest cable can be made to transmit speech, and if speech, the less frequent impulses of automatic telegraphs.

*See *Electrical World*, vol. xvi., p. 208, 1890.

Many experiments have been made in the author's laboratory with arrangements of apparatus set up to imitate by condensers and resistances the retarding properties of actual cables. An example will suffice. A section of artificial cable was made up of a resistance of 7,000 ohms, and a capacity across between line and earth of 10 microfarads. Through this cable not a sound could be transmitted telephonically to a double-pole Bell receiver at the distant end, either with a Blake transmitter (with induction coil) or with a Hunnings transmitter without induction coil. When, however, a single compensating self-induction coil, having a resistance of only 31½ ohms, and a time constant of about 0.005 second, was bridged across at an intermediate point, telephonic transmission became at once possible, save for very shrill sounds.

One curious result came out in one of the series of experiments, namely, that those telephonic transmitters which have induction coils in them (the ordinary mutual induction coils with thick and thin winding), are almost useless for the purpose of cable transmission. Apparently the fine-wire winding has too great a self-induction in series in the circuit, to be suitable for this purpose. At any rate, better results were obtained from transmitters of other types. Quite recently the author has got better results from a transmitter in which the ordinary two-wire mutual induction coil was replaced by a single self-induction coil on a plan suggested by him in 1884. It is obvious that any plan which contemplates the counter-balancing of retardation by shunting (through self-induction coils) a notable fraction of the current, may necessitate a new type of transmitter capable of sending telephonic currents of much greater amperage than those ordinarily used in overland telephony.

So far, the evidence for the effective operation of self-induction has been considered. But there exists also much evidence to show that mutual induction by devices properly distributed along a twin-wire cable will also be effective in neutralizing the retardation due to distributed capacity. It is an old and well-established rule that the retardation in a cable is proportional to the square of its length. If one could cut a 2,000 mile cable into two cables of 1,000 miles each, and simply translate or relay the current from one into the other, the retardation of the whole ought to be reduced very materially, perhaps not to one-quarter, but at least to one-half. Only here, again, it is evident that

some of the electric energy supplied at one end must be used up in the act of working the translator or relay, however it is constructed, even if it be only a simple mutual induction coil. Therefore, if a cable is cut up into numerous sections, each connected by mutual induction with the next, a considerable fraction of the energy put in at one end may never reach the other, being spent on the road in overcoming the retardations that would otherwise arise. For land lines it has often been proposed to cut up the line into parts, as for example, by Edison in his patent No. 150,848, in which for the attaining of greater speed he shows a line divided at three intermediate points where the circuit is grounded through mutual induction coils. The objection to ordinary induction coils for the purpose is that they are never well enough made from the inductive point of view. If they are not so constructed that *all* the magnetic flux due to one of the sets of coils interlinks itself with the other coil, then each coil will possess an unbalanced self-induction, and will offer an impedance. Mutual induction, as is well known, tends always

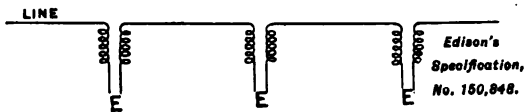

FIG. 12.

to wipe out the self-induction of both the circuits thus brought together; but with the most perfect conditions of magnetic circuit, the utmost that the mutual induction can effect is to neutralize the self-induction only of those coils which are acting as mutual inductors. It cannot neutralize the self-induction in parts of the circuit beyond. Hence, for the particular purpose in question—namely, that of enabling the circuit to transmit telephonic signals—the induction devices must not be simple ordinary coils inserted haphazard at intervals; they must be specially designed and inserted with perfect regularity. And the cable itself must be freed as far as possible from self-induction. *Never, for such a purpose, must a cable be constructed, as Atlantic cables have hitherto been, of a single conductor (of stranded copper) surrounded by an iron sheathing that comes in between the outgoing and the returning parts of the circuit, thus adding an enormous impedance. Happily, in all twin cables where outgoing and returning conductors lie side by side within*

the sheath, the iron of the sheath, enclosing both, increases the mutual induction between them. As the author pointed out in 1890, in the discussion on the London-Paris telephone line, the mutual induction of the twin cable is a positive gain, enabling transmission to take place far beyond the limits previously assigned from considerations as to capacity and resistance alone. In such constructions as Fig. 6 the iron used to increase the self-induction of the wires that act as compensators will of itself increase the mutual induction between the twin conductors if they are properly disposed. The experience gained with alternate current working is absolutely conclusive as to the efficient action that may be expected in special constructions for future ocean telephony.

IV.—CONCLUSION.

Ocean telephony is possible. The means for attaining it are within our grasp. Compensated cables of the new type are entirely practicable. It may be needful to begin with some shorter line than an Atlantic cable, in order to gain experience. But an Atlantic cable constructed on the new plan will not cost much more, when laid, than one of the old type; and whether or not it is successful in conveying telephonic speech, it will certainly transmit telegraphic messages at a greatly accelerated speed of signalling. If one Atlantic cable can be constructed to do the work now requiring eight cables, that cable will be constructed. Acceleration of the ocean telegraphic service, is in itself a desirable step in advance; but the advance will not be complete until telephonic speech is transmitted also from shore to shore.

At the conclusion of Dr. Thompson's paper, which was greeted with great applause, it was resolved, that the discussion of said paper should be postponed until the next session of the Section, as the hour for adjournment was near, and the discussion could not be finished at the present session.

The Chairman then announced that owing to the number of papers assigned to Section B, some of which could with equal propriety have been assigned to Section C, it was under discussion to transfer some of them to Section C, and if that programme was carried out, due announcement of it would be made in Section B.

The following papers were afterwards transferred to Section C: "Various Uses of the Electrostatic Voltmeter," by Dr. J. Sahulka.

"On the Construction of Cables for Subterranean High Tension Circuits," by Dr. A. Palaz.

"On Direct Current Dynamos of Very High Potential," by Prof. F. B. Crocker.

The meeting then adjourned until August 23d, 1893, 10 A. M.

SECOND MEETING, WEDNESDAY, AUG. 23, 10 A. M.

Section B was called to order by the Chairman, Prof. Cross, at 10 A. M., and the minutes of the meeting of August 22nd were read by the Secretary, and were approved.

THE CHAIRMAN:—The next business in order is the consideration of the paper of yesterday, read by Dr. Sylvanus P. Thompson, F. R. S., on Ocean Telephony. The paper is open for discussion and we will be glad to hear any remarks or questions thereon.

DR. CARROLL: I was greatly interested in the paper as read and the beautiful illustrations that were given and the principles sought to be illustrated, but it occurred to me then, as it occurred to me before, in my private work in my laboratory, that we, practical electricians, that are working along the line indicated in the paper, as well as on the line indicated in the paper preceding, possibly may not have attained the best materials for performing the services, namely, in the cable alluded to, that the materials were not the ones that would give the best results. We have confined ourselves to iron and copper as conducting and inducting materials. Now I have been working for thirty years along the line of alloys to determine the effect of the electrical action upon them.

I will take but a moment of your time, but I want to put in your hands an alloy or a series of alloys and ask you to appoint a committee that shall examine and test these alloys with reference to their uses in electricity. The alloy I now have in my hand is one of great conductivity, greater than copper. And I believe, although we do not know a thing until we have tested it, I believe instead of giving twenty-five words per minute over a cable, this alloy would give double that number of words, because of less resistance. I have tested alloys of aluminum, silver and copper. I have tested 200 alloys of aluminum, some of which will give wonderful conductivity: much greater than copper and others not half as much as copper, hence you cannot determine by looking at an alloy what you will get. I have now in my possession an alloy of the aluminum, copper and silver, which has to-day a tensile strength of two thousand pounds, which six months ago had a tensile strength of twenty thousand pounds. All that change has taken place by electrical action.

Here is another alloy that had a tensile strength of thirty thousand pounds that has to-day forty thousand, by electrical action. This merely shows that electricity, that wonderful something about which we know so little, the best of us, has effects that it is performing and does perform on alloys that make their properties different to-day from what they will be to-morrow.

DR. HAYES:—I would like to ask a question. I have always found in considering transmission of a telephonic nature that it has been desirable to look at it from two situations; that of attenuation and distortion. In a twin cable we have the two cables added to the two factors of attenuation and distortion, the fact that we have one capacity in the thin cable. In the cable that Professor Thompson has brought before us, he found the injurious action was produced by distortion by the use of electro-magnetic resistance centred between the wires, thus recognizing that electro magnetic resistances are practical and reciprocal. Professor Thompson referred to the bridging bells which have been brought into use in the United States on all our lines to show that we are practicing the placing of electro-magnetic resistance between our wires.

In practice we find to-day that we are obliged to make the electro-magnetic resistance of sufficient duration to allow higher attenuation of the current. If we had a telephone in the bridge with electro-magnetic resistance practically no sounds would be heard.

If we have electro-magnetic resistance placed across the line with sufficient impedance, we would get benefits from reduced distortion. Or, if we have them sufficiently low we would have benefits from less injurious distortion.

PROF. ANDREW JAMIESON, of Glasgow:—I take the very greatest pleasure in complimenting Dr. Thompson on his very clever solution of this problem. He put before us the whole question in the clearest light possible, and in as few words as could be done. It often happens that electricians are able to tell and prophesy what would be a result under certain circumstances, but it is very seldom they are able to give us a practical solution of the difficulty. Dr. Thompson has not only put before us this problem, but he has given us a solution thereof. He will, however, have to rely on the great cable engineers of the world in order to get it into shape. As you know, there are only two firms in the world that have laid cables across the Atlantic, The Commercial Construction and Maintenance Company and Siemens Brothers, of whom we have an able representative with us.

Now, it is astonishing in Dr. Thompson's paper that he makes this statement: "It speaks only with the still slow signals of the "mirror galvanometer or of the siphon recorder. Six or eight " words per minute slowly spelled out are the usual limits of " working of an Atlantic cable." But he corrects that to twenty-

five words a minute. Dr. Thompson has learned something since he came to America.

Looking at Dr. Thompson's device the cores would cost at least twice the amount of the present cable cores unless he was able to make them of a very much smaller diameter. It costs forty pounds per knot for the Atlantic core, it would cost eighty pounds for his. It would of necessity be much more complicated and these firms who hold the ground would not come under the very strong rules which they have hitherto done in regard to time.

There is one question I wish to ask Dr. Thompson, and it is this: Supposing there are two conductors, *A* and *B*, similar to the present Atlantic cable, and a third wire *c*, which is an empty induction wire, (Fig. 6), wouldn't there be an induction between *A* and *c*?

DR. THOMPSON:—The mutual induction of *c* and *A* would be cancelled by the corresponding mutual induction of *B*.

PROF. JAMIESON:—Another point and the last point is, namely: How will Dr. Thompson localize the faults in these cables? Will he have to treat the whole three cables as one? That is one of the principal things we have to consider and guard against, and that is, to be able to locate the fault when it occurs.

MR. THOS. D. LOCKWOOD, of Boston:—The great trouble in discussing a paper like this is that the author usually has had an excellent opportunity to consider the subject, and that his hearers have not had; this discrepancy between the opportunities of the author and the auditors is very greatly accentuated where the former is so pre-eminently gifted by nature as a theorist. The main difficulty of the subject, that I see, is, that in its present stage the discovery not having been practically tried, and not likely to be soon practically tried, the author has the opportunity of having both sides of the subject, and of saying all or nearly all about it that there is to be said; and I think he has said nearly all, because every one here will agree with me that, with respect to such a suggestion as this, of transmitting articulate speech through a long cable, the only proof of it is in the practice. The proof of the pudding must be in the eating. I have this suggestion to offer to Prof. Thompson, that although it may not be possible to get a cable 3,000 miles long to make a practical test, it may be possible to get a shorter cable, and try if it is not possible to get a submarine cable or get a number of underground cables and piece them together until they are long enough to try the experiment practically. I have to leave you rather unceremoniously to participate in a discussion in Section C, but before I go I wish to say that although I have not had the privilege of hearing the paper read, I have had what I consider a much greater privilege, namely that of reading it, and have had an opportunity, although not as long as could have been desired, of digesting it, and I wish to tender my tribute of admiration to the paper presented to us by Prof. Thompson.

MR. CHARLES CUTTRISS, of New York, spoke as follows:— Sometime ago I got Dr. Thompson's paper. I thought I would look into the matter and have some experiments made; so under my instructions the superintendents at the different stations made three series of experiments. All of these three ought to come exactly alike but the speeds were not alike. The one joined by the metallic circuit was weaker. The way the experiment was made was as follows: We took a recorder and put it in an automatic transmitter giving a frequency current of about 500 per minute, which was our maximum rate of speed. We found the gap recorded exactly in the same condition for all the experiments. No other change was made except to shift from one circuit to the other. As I say, the metallic arc was the most, the straight call came next, and the metallic is very much smaller. That seems to be directly in opposition to the statement in the paper as to the experiment that has been arrived at over the Dover cable. Of course these things will come in, and I simply mention it to show the fallacy of sometimes trying experiments on artificial lines, and imagining they will give you the same effect as actual cables. I think the experience of anybody who has tried making a good current transmitter will show that although his current transmitter will work beautifully on artificial work, when he puts it on a cable he is worse off than before.

It makes its signals clear, it makes them almost nothing; between the two evils it is better to keep the signals not so clear, and give the operators an opportunity to do better work. If, by experiment on our cable, we could in any way assist Prof. Thompson, I should be most happy to do so.

MR. OLIVER HEAVISIDE:—Mr. Chairman, I think I speak not only my own impressions, but all those present during the reading of Prof. Thompson's admirable paper, when I say the subject discussed therein is of enormous importance both from a scientific and commercial standpoint, and that we are greatly indebted to Dr. Thompson for such a suggestive paper. Since Dr. Thompson has mentioned my name in connection with the great system of telephoning, I venture to say that my experience in the British post office, dating from 1877, confirms in a great degree the general principles laid down. I may state this, that very shortly after the introduction of the telephone in the north of England we found that the limits of distance through which it could be worked was exceedingly small, no electro-magnet being joined in series, because in that neighborhood nearly all the municipalities insisted on the wires being placed under-ground. We found that the remedy was to join up all the electro-magnets in a bridge. We joined up, say twenty-six in a certain case, not upon an artificial line, but upon a practical line. Our limit working through an ordinary underground work extended out to

thirty miles. Our underground work was not especially adapted to underground telegraphy. I should state in addition to that we had some automatic arrangements by which we could measure the indicators, and by putting observers and placing in silence boxes at each end they were not aware of what we were doing, but they were always able to find in the presence of the electro-magnets beneficial results. These electro-magnets were not designed to give the best speed. We were obliged to make a compromise. I haven't the least doubt if this were developed, of course commencing upon a small scale, you could get desired results, if you will use plenty of copper, which is the principal factor in the distortion of the signals.

PROF. HENRY D. WILKINSON, of London, Eng.:—I should like to express the extreme satisfaction this paper has afforded me in having offered so able a solution of the problem of ocean telephony and telegraphy at high speed. I should like to ask Prof. Thompson whether the effect of this third wire of his does not cause further retardation of the signals in consequence of the fact that has been pointed out. Would not the hysteresis of the iron cause additional retardation? I should like to ask him whether he considers that the effect of retardation would be completely wiped out by his method of construction?

I can only say I appreciate very highly the able character of this paper and compliment Dr. Thompson upon it.

MR. A. E. KENNELLY, see page 487.

MR. ALEXANDER SIEMENS, of London:—I think that the subject ought to be looked at as well from a practical standpoint as from a theoretical. We all know in commercial matters the first thing to be considered is cost. Now, what I object to in the cable proposed by Prof. Thompson is, that it is extremely difficult to construct, and that it will cost considerable more than the single cable which will give exactly the same speed, and the Professor has certainly corrected what he said yesterday, for if he speaks of eight words per minute he certainly shows he is not quite up to date as to what is being done. I think it is entirely overlooked that capacity is not the only enemy of telegraphy, but the electrification of the material plays a great part, and that is just the reason why overhead lines offer no particular difficulty for long distance telephoning, because the air has practically no electrification, while the underground material has a good deal of electrification, but we do not get over that by the device suggested by Professor Thompson. I would also say the same objection applies to that alloy which was shown.

We do not want a conductor better than copper, but at the same time it is really the commercial consideration which makes these fancy constructions, which are very good theoretically, impossible.

THE CHAIRMAN:—A point occurred to me that has not been alluded to specifically, because very likely it is old to experts in

telephony. There is this manifest difference between cable telegraphy and cable telephony : in the former the precise form of the electric wave is of minor importance, at most only affecting the speed. In signalling with a siphon recorder a slight departure from the normal form of the current wave does not do any great harm, as there is a gradual passage from distinct legibility to illegibility. But in telephonic transmission a very slight deviation from the proper form of current wave causes complete loss of intelligibility. The impression is oftentimes very short and, therefore, if the articulation is really poor, increased loudness may perhaps be a hindrance rather than a help, there being no difficulty in understanding speech in the absence of disturbing sounds with very imperfect transmitters, provided only that they give the wave in its proper form. This of course renders the delicacy of telephonic transmission greater. Perhaps some person can inform me if any measurement has been made of the strength of the telephonic current when it enters at Chicago, and when it emerges at Boston. Some quite crude experiments on the line between New York and Boston give for the current reaching Boston only about one per cent. of the strength of the current at its entrance into the cable at New York.

PROF. SILVANUS P. THOMPSON :—Mr. Chairman. I have been feeling rather like the individual in one of those side shows that can be found a few miles away from here, where there is a booth erected and at one end of that booth there is a partition with a hole in it and a negro boy presents his face there to be shot at ; he has to find out how to ward off one blow after another, but dare not desert his place. I have to stand the fire of my friends. I will now try to ward off their blows. Some of them have said very pretty things about me and about my effort, and I thank you very much for the compliment, but I hope I shall not be blinded by it, because if there is any discovery or invention in what I have laid before you I hope I shall be the first to recognize that the discovery or invention will be absolutely worthless if it cannot stand the fire of criticism, not only here but everywhere. The first stage of success is to know what the difficulties are that have to be met. In spite of all the fears that have been expressed that this way of working will not be practicable I still remain unconvinced, I still consider that I have got on to the right track, and I earnestly hope I may have the co-operation of the large corporations throughout the world and the co-operation of the large manufacturers who make cables. I shall be the very first to say that no man could hope without such co-operation to arrive at success, because if he does not get that co-operation he will have to encounter numerous difficulties. The matter practically rests with the cable companies, the cable companies of the world, whether they will choose to fathom this idea of mine to the bottom and show me where I am wrong. But the idea is so

clear in my mind that I cannot resist the logical conclusion that this is the right way of construction. Perhaps I might be allowed at this time to call attention to a point of evidence as to such inductive leaks. Here is a case in point, the cable on the West African coast from Sierra Leone to Bona, the length of that piece being between sixteen and seventeen hundred miles. The intermediate point at Aghrua is about a thousand miles. It was found in practice for the purpose of telegraphy, that if you desired to work to Sierra Leone and further it was not best to join the ends at Aghrua, that it was better to put on the inductive leak at Aghrua. Supposing you had eight or may be sixteen inductive leaks, speed signalling would be very much increased; you might require a different mode of transmitting. That is my claim, that by carefully arranging these inductive leaks you can use the induction but you will have to pay for it; yet the amount of proof remains the same. I would like to refer in detail to a few of the remarks that have been made. Mr. Lockwood tells me that I have discovered since I came to the States that the Commercial cable works twenty-five words per minute instead of eight. I did not know that they worked to that speed, but the Commercial cable is the only one that does. I very much doubt if the speed of signalling of the others exceed more than six or eight, including the gap. The speed from Bombay, which is about 1,800 miles long, only gets up to eighteen words a minute. It is a joke you know when you want to make a record of speed. You choose the words that have the shortest letters. I think the sentence usually used is, "It is so hot, so hot it is, it is so very hot." You can send that at a tremendous rate, but twenty-five words a minute if it means that all the eight cables that have been laid across the Atlantic can work at the rate of twenty-five words per minute, why, I should think we could do ten times as much if we only could find out how to compensate that which causes retardation. The speed might be increased certainly more than ten fold. Prof. Jamieson has suggested to me that the cost would be very much greater. I think he puts it at forty pounds a mile as to the cost of the core. I think there are some electrical companies that would be very glad to provide a core for forty pounds.

MR. SIEMENS:—We would not make a core for that.

PROF. JAMIESON:—It is too low a price.

PROF. THOMPSON:—There is a very great difference between the cost of making the mere core of a cable and the cost of completing that cable and laying it, and let us not confuse the one thing with the other. The cost of making a cable such as I have suggested with two cores, which does not need to be well insulated, and three cores which need to be insulated is different.

Now another point: Prof. Jamieson asked me how I would localize the faults. The localization of cable faults is a very nice exercise, but we all know Prof. Jamieson's reputation as a most

accomplished faultfinder. I use the term in an entire complimentary sense, and if Mr. Jamieson cannot find a way of localizing a fault in a cable like this, I should like to ask Mr. Wilkinson to try his hand, and then I should like to ask Mr. Kennelly if it is out of the range of science, and I should be very much astonished if Scotland, England and America could not localize the fault. I will answer the point Mr. Wilkinson raises, whether the third wire would not of itself introduce a new action of retardation, I am not sure that would be important in a particular case. Prof. Jamieson asked me whether there would not be an interference to mutual induction between Δ B and C , C being this compensating wire. That might be guarded against by surrounding C with another wrapping of iron. It certainly could be guarded against by increasing the self-induction of C , while it does increase the mutual induction between Δ and B .

PROF. THOMPSON:—Mr. Siemens raised another point that he called electrification of the inducting material coming into play. I think he means electrification that will remain after the conductor has been discharged. I don't think the serious part of the retardation to be found in the cable arises from dielectric disturbances. Such a secondary consideration would not frighten us off from the main problem. I think I said it would be wiser to begin at some shorter length than the whole Atlantic cable. That is indeed what Mr. Lockwood was good enough to suggest to me. It is important that all suggestions, if they have any merit, if they receive your favorable consideration, it is important for the progress of science that they shall be tried, and I do certainly hope that somebody will stir it up and give my project a trial, for nothing short of a practical trial will satisfy me, or anybody else, perhaps, that my suggestion is not one that has not in it the germs of future improvement.

MR. CUTTRIS:—I wish to clear Dr. Thompson's mind from any idea that the figures given in regard to the speed on Commercial cable was bogus. There were five actual observers.

PROF. THOMPSON:—If by employing a mechanical transmitter you can transmit twenty-five words, then I say your method of transmitting has made very great advances. There is no doubt but your cable possesses better properties than older cables.

THE CHAIRMAN:—I will next call for the paper by Dr. Lindeck on "Materials for Standards for Resistance and their Construction."

MATERIALS FOR WIRE STANDARDS OF ELECTRICAL RESISTANCE.

BY DR. STEPHAN LINDECK,

Assistant to the Physikalisch-Technische Reichsanstalt Charlottenburg, Berlin.

More than thirty years ago Werner von Siemens proposed to fix the practical unit of electrical resistance by such a definition, that by referring back to the units of length and mass and by the use of mercury, an element chemically and physically so well defined, the unit would always be reproduced with exact accuracy.

This proposition at the time was greatly opposed, but its correctness in the course of years has been proven more and more, and is demonstrated in the most striking manner by the fact, that this proposition is suggested for International approval at the present Congress, as a further development of the resolutions passed at the Congresses in Paris in 1881 and in 1884.

The accurate reproduction of mercury resistances, as is well known, requires great care, and the use of the same is, therefore, limited to a few well arranged laboratories; the question still remains, which material, according to modern experience, is most suited for secondary wire standards, which are almost exclusively used for practical measurements. This question was first considered by the Electrical Standards Committee of the British Association, in the beginning of the sixties. The committee resolved to make copies of a german-silver resistance, which had been absolutely determined, out of various alloys, and to adjust therefrom ten unit coils, whereof two respectively consisted of platinum-silver, gold-silver, platinum-iridium, commercially pure platinum and mercury. It was expected that the choice

of so many different materials would assure that the result of the absolute determination could not be lost.

For the material used for the copies, which were distributed by the committee, the platinum-silver alloy was chosen; Dr. Matthiessen, to whom this work was entrusted, recommended this material on the strength of several years investigation, and it has been greatly used since for standard resistances in England and in this country. Nevertheless it is not possible to rely absolutely upon the constancy of a resistance standard made of this material.

The following measurements made by me in the Reichsanstalt with a resistance coil furnished by Elliott Bros., London, will show this. This coil was tested during two successive years in the Cavendish Laboratory in Cambridge.

PLATIN-SILVER.

A			COMPARISONS IN CAMBRIDGE.		
Date.	Resistance.	Remarks.	Date.	Resistance.	Remarks.
1892.			1891.		
March 1.....	1.000697 (B 22)		March 4.....	0.99924	At 13.9°
" 2.....	697 (B 23)		" =	1.00100	At 16.85°
July 20.....	1.002629 (B 23)		" =	1.01120	B.A.U. at 16.85°
1893.			1892.		
July 17.....	1.000556		July 25.....	1.01107	At 17°
" 18.....	1.000566		also =	1.01103	B.A.U. at 16.85°
B					
Resistance at 18° C.		Remarks.			
0.98545		} Heated to 40° C. Temp. of the Lab. very low.			
0.98518					
0.98555					

Entirely independent observations thus proved that the value of a resistance made out of platinum-silver has constantly diminished in a period of two and one-half years. The changes remain, it is true, within the hundredths of one per cent., nevertheless they exceed the limits allowed for standards.

Another example showing considerable changes of such a resistance, I take from a late publication by Elmer G. Willyoung.*

* "Some new apparatus for the most exact comparison and the adjustment of resistance standards, etc.," Journal of the Franklin Institute, February, 1893.

The respective observations were made during a period of a fortnight.

GERMAN-SILVER.

I.—NOT ANNEALED AFTER WINDING.			II.—ANNEALED AFTER WINDING.		
Date.	Resistance at 20° C. (in Ohm).	Remarks.	Date.	Resistance at 20° C. (in Ohm).	Remarks.
1889. Feb. 13...	2.2460	Before winding.	1889. Feb. 13...	2.2470	Before winding.
" 14...	2.2594	After winding, increase through winding, 0.60 per cent.	" 14...	2.2666	After winding, increase through winding 0.87 per cent.
" 15...	2.2597	" 15...	2.2733	After heating to 90° C. during three hours, increase through heating 0.29 per cent.
" 16...	598	" 16...	732
" 22...	603	" 22...	733
Mar. 4...	608	Mar. 4...	734
" 19...	612	" 19...	729	Temperature changed during the measurement.
April 6...	615	Time variation in two months, 0.09 per cent.	April 6...	732	Time variation in two months, practically nothing.

Mr. Willyoung says: "Permanent increase if subjected to low temperatures, and decrease if to higher temperatures, are well-known characteristics of the alloy."

The question as to the most suitable material for wire standards was again taken up at the congresses in Paris of 1881 and 1884. Dumas called attention to the alloy of platinum and iridium, of which material the standards of the metre and the kilogramme are made.

In how far this alloy is appropriate for wire standards of resistance has been investigated by Dr. Klemencic in an interesting paper published in 1888, which at the same time embraced the study of several other alloys, such as german-silver, nickelin and platinum-silver.

Of special interest are his researches on the influence of mechanical stress on the resistance of a wire. It is a known fact among the manufacturers of electrical resistances, that during the winding up of the coil and in the time subsequent to the winding, considerable changes occur which diminish, but can be observed even after some years, that material of course will be most suitable, of which the specific resistance is altered in the least degree. The following conclusions are arrived at by Dr. Klemencic on the basis of his extensive researches, which cover

the specific resistance, coefficient of temperature, thermo-electromotive force against copper, and the influence of mechanical deformation; of the alloys, platinum iridium, platinum-silver, nickelin and german-silver, the first two are the most appropriate. The platinum-silver, however, is preferable on account of its small coefficient of temperature (0.12 per cent. against 0.027 per cent.). The next best would be nickelin; this material is likely to be identical with the patent nickel to be referred to later on. (It is to be regretted that no chemical analysis of these materials was made.) However, it is a matter of fact that the thermo-electromotive force of nickelin against copper is much higher than of the other materials, and this is of great importance; for the connecting pieces in resistance standards are always made of copper. German-silver, the alloy which has been almost exclusively used for standard resistances on the Continent, is the least desirable. In England an alloy called platinoid, which does not differ much from german-silver, is in common use. For all alloys, time variations were found, which consisted in an increase of resistance for german-silver, and in a decrease for platinum silver and platinum iridium.

Klemencic further made the important observation that the rate of time variation is influenced to a high degree if the wire is heated to a temperature of 40 to 50° centigrade, in order to determine its coefficient of temperature. He says: "Perhaps it would be preferable to expose a newly made standard resistance to a moderate rise of temperature during a longer time, in order to terminate more quickly the variations of resistance produced by mechanical stress." Klemencic did not, however, continue his work in this direction.

One of the duties of the Electro-Technical Laboratory of the Physikalisch-Technische Reichsanstalt, which was founded in 1887, principally by the liberal donation of Werner von Siemens, is to examine the correctness of electrical measuring apparatus, and to make such investigations, which tend to improve them.

As to electrical resistances the determinations of the absolute value of the ohm made some years ago by Kohlrausch and Himstedt have shown to what degree wire resistances can change in the course of time.

It is a matter of fact that Kohlrausch has observed for two german-silver standards an increase almost equal in both to the amount of more than one tenth of a per cent. in one and three quarters of a year.

It was, up to the present time very difficult to manufacture accurate standard resistances. It was necessary to take wire which had been made a long time before; to wind at the same time a larger number of coils which were not to be disturbed for several months; then periodically the value of the resistance was determined and those were chosen for standards which proved to change in the least degree; nevertheless such resistances are not constant at all. During many years changes can be observed, as for instance Mr. Carpentier has shown; this was also proved with a carefully constructed resistance, furnished by Carpentier to the Reichsanstalt. Such a resistance must be considered to be in an unstable state. A somewhat larger change of the outer temperature may effect considerable changes, as we have seen it before with a platinum silver resistance.

Thus it was well worthy to investigate whether it is not possible to manufacture standard resistances in such a way that they show a steady value for all practical purposes within a short time after the winding, and not after several years.

The following is a short account of the researches made by Dr. Feussner and myself upon this subject in the Reichsanstalt, which were undertaken before the paper by Dr. Klemencic was published.

For different materials we determined :*

1. The chemical composition, the temperature coefficient, and the specific resistance of the material.
2. The variation of resistance through the strain produced by winding.
3. The time variation during the period subsequent to winding.
4. The influence of heating to different temperatures.

As regards the variation of resistance through winding, it was observed that the resistance of all kinds of wire increased by winding, as would be expected, the increase being more pronounced for a given gauge of wire the less the bobbin's diameter. This increase is due to a mechanical hardening of the wire by strain, and it is well known that the resistance of any metal is less in the annealed state than in the hardened condition.

In the first place we investigated a german-silver alloy which

* Some of the results here quoted as to the influence of stress and of a moderate rise of temperature were previously arrived at by Dr. T. Klemencic (*Sitz.-Ber. Wien. Akad.* 97, 1888).

the firm of Siemens and Halske, in Berlin, used for standards at that time. It appeared that the increase of resistance through winding could amount to one per cent., and that the time variation during the following months was very considerable; the latter showed itself always as an *increase* of resistance. Another remarkable circumstance is the further *increase* of resistance (amounting to a few tenths per cent.) by heating such a wire for several hours at about 100° C.

It might be supposed that the wire would be annealed by the effect of the high temperature, and that its resistance would therefore decrease. But our extensive investigations gave the important result that heating causes an *increase* of resistance in all alloys containing zinc to any considerable amount. On the other hand, all alloys examined containing no zinc show a *decrease* of resistance under the same conditions. The increase of resistance by winding is also much more pronounced with alloys containing zinc than with those in which this metal does not occur. All this seems to point out that in the former alloys, changes of structure go on, which are accelerated by any kind of stress or by variations of temperature, and always tend to increase the resistance. These changes of structure also become apparent by the time variations, which occur when the resistance coil is left to itself. The latter observations are in perfect agreement with what was found by former observers on the time variation of german-silver. The interesting result was then arrived at in close agreement with the suggestion of Dr. Klemencic, that the time variation would be much accelerated by heating the resistance at a high temperature, say 100° C., for a few hours. Within two months after winding, the period in which german-silver varies most, variations could not be shown within the errors of observation in wires treated in the manner described. During longer periods, say one or two years, variations would still occur, even with *annealed* german-silver coils. But they hardly reach the *tenth* part of those occurring when this process has not been gone through.

The following table shows the results of one of the experiments with two wires of german-silver (60 per cent. *Cu*; 25.4 per cent. *Zn*; 14.6 per cent. *Ni*). In both cases the wire (1 mm. in thickness) was wound on a bobbin 10 mm. in diameter. The wire I. was left to itself after winding, whereas the wire II. was annealed after winding by heating it to a temperature of 90°

Centigrade for three hours. The resistance of each was measured at intervals of nearly two months from time to time.

Quite analogous results were obtained with other alloys containing zinc which have been much used for standards in Germany. The less the percentage of zinc, the less became the above mentioned variations of resistance.

As these zinc-containing alloys showed themselves so unreliable, we extended our investigations to other alloys.

A few years ago the firm of Siemens and Halske, in Berlin, made use of an alloy on account of its comparatively low temperature coefficient (0.02 per cent. per 1° C.), called patent-nickel. This was tested in the Reichsanstalt in the same way as the other alloys. It contains about 25 per cent. of nickel and 75 per cent. of copper. The experiments gave the following results :

1. The variations of resistance by winding are considerably less for this material than with alloys containing an appreciable amount of zinc.

2. Heating produces a *decrease* of resistance. There is, however, not the slightest evidence for a change of molecular structure.

Materials with such properties are evidently much more appropriate for the construction of standard resistances. It was, indeed, found, by comparison with mercury resistances, that coils of "patent-nickel," which had been, as we call it, artificially aged by heating at about 140° C., have remained constant for two years within a few thousandths per cent. In the following table, for instance, are stated the differences of two patent-nickel standards of 1 ohm (No. 22 and No. 23), as observed at different times :

PATENT NICKEL.

Date.	Difference of No. 23-No. 22 in Ohms.	Date.	Difference of No. 23-No. 22 in Ohms.
1890.		1891.	
June 21	0.00012	May 9	0.00009
July 11	11	July 30.....	10
November 25..	11		
1891.		1892.	
January 29...	10	March 1.....	9.2
May 2. . . .	8	May 21.....	10.1
		August 19....	9.4
1892.			
September 8..	0.000092		
October 25-27	95		
December 12.	94		
1893.			
June 16.....	103		

On the other hand, from comparisons of the sum of No. 22 and No. 23 with four different mercury standards (I., II., III., and IV., each of about 1 ohm) I proved that the absolute values of the two standards had remained constant within the errors of observation, as the following numbers show :

Date.	Values of No. 23 at 20° C. deduced from Comparisons of No. 22 + No. 23 with the Mercury Standards.				
	I + III.	I + III.	III + IV.	I + IV.	I + II.
Nov. 1890.	0.99990	0.99986	0.99988
Feb. 1891.	0.99989	88
June 1892.	85	88	0.99986
July 1892.	89	89	89

The "patent-nickel" would therefore be a material well fitted for resistance coils.

A large number of alloys was then examined by Dr. Feussner, consisting of nickel and copper only. An alloy containing about equal amounts of each metal was found to have an extremely small temperature-coefficient. Unfortunately, however, the thermo-electric effect of these alloys against copper is even higher than for patent-nickel. For the alloy just mentioned, called "constantan," it amounts to nearly forty microvolts per degree centigrade, considerably surpassing the thermo-electromotive force of most of the usual thermo-junctions, like iron—german-silver, for instance. A drawback is however its high thermo-electromotive force against copper.

On the whole, our experience has led us to the conclusion that for standards such alloys do best which, besides copper and nickel, also contain manganese. Some years ago Mr. Weston, of Newark, N. J., discovered that alloys containing manganese possess a very small temperature-coefficient, and that it is even possible to obtain metals with a negative temperature coefficient in this way. I am not aware how far this discovery has been practically taken advantage of in this country. After hearing of Mr. Weston's observation, the further investigation of manganese alloys was taken up at the Reichsanstalt, and we obtained very interesting results.

The alloy, which is now being regularly manufactured and brought out under the name of manganin, consists of 84 per cent. of copper, 12 per cent. of manganese, and about 4 per cent.

of nickel. As the observations made by me for the last two years in the Reichsanstalt have shown, this is a most appropriate material for standard resistances.

The general character of the resistance variations of manganin with temperature, may be best understood from the diagram (Fig. 1), in which temperatures are taken for abscissæ, and the resistances of a hundred-ohm standard are plotted as ordinates. In this case up to 40° C. the temperature coefficient is positive, the absolute value, however, being very small, as the table of the

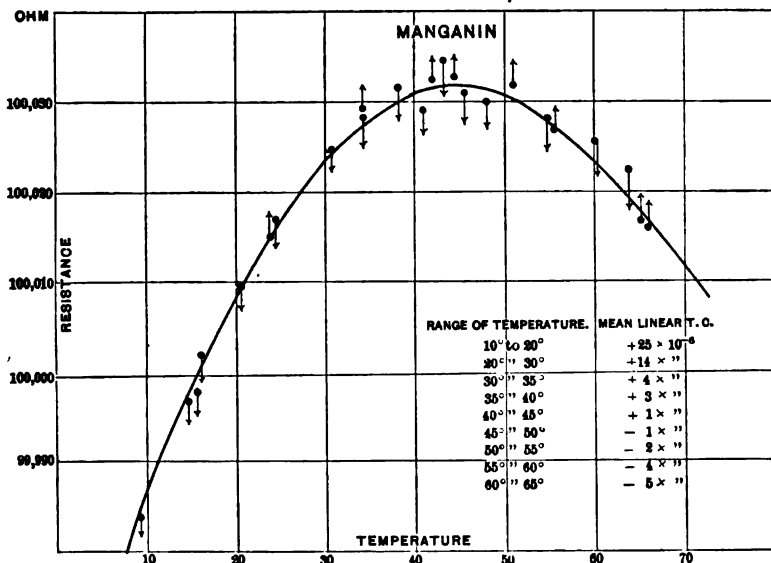

FIG. 1.

mean linear coefficients between the temperatures stated in the first column shows :—

Range of Temperature	Mean Linear T. C.	Range of Temperature	Mean Linear T. C.
10° to 20°	+ 25 × 10 ⁻⁶	45° to 50°	- 1 × 10 ⁻⁶
20° " 30°	+ 14 " "	50° " 55°	- 2 " "
30° " 35°	+ 4 " "	55° " 60°	- 4 " "
35° " 40°	+ 3 " "	60° " 65°	- 5 " "
40° " 45°	+ 1 " "		

For most purposes, the variability of resistance with temperature may now, indeed, be quite neglected. As a matter of fact, very elaborate and sensitive methods are required to demonstrate the existence of any temperature coefficient at all. On raising

the temperature beyond 50° C. the resistance attains a maximum, thence to diminish again. In this latter part of the curve we therefore actually have a negative temperature coefficient.

In order to show that at the same temperature the resistance always returns to the same value—in other words, that there is no hysteresis in the relation between those two quantities, some points of the curve were determined with temperatures descending from 70° C., whereas others were obtained with ascending temperature. This process was repeated several times. All points are extremely close to the same continuous curve, and it is quite obvious that this curious behavior is a constant physical quality of the material. Of course such a resistance coil must have been artificially aged before the beginning of the observations; it was indeed heated during five hours at a temperature of about 140° C. Otherwise, as I mentioned before, a progressive process of decrease of resistance through annealing would superpose upon the regular variation of resistance according to the curve. It is true that this maximum resistance point does not always occur at exactly the same temperature for different wires; it is well known that the electrical constants of all resistance alloys change slightly with the gauge of the wire. But it is also true that the maximum resistance-point of manganin of a thicker size—as it is used for one ohm standards—occurs, as a rule, at about 30° C., and so at ordinary temperatures the temperature-coefficient is even less than for this particular specimen of wire.

The material is very soft, and can be drawn to the finest gauges; but *it must not be annealed in free air*, because the manganese then would oxidize, and the qualities of the material would be altered. Thus it is not possible to buy, for instance, a wire, say 1 mm. thick, and to draw it down to the required gauge without taking proper precautions. As to the constancy of manganin resistances I will quote a few figures. These figures refer to a resistance which is used to determine the electromotive force of the standard Clark cells with the silver-voltmeter. Thus very often (more than fifty times) a current of about half an ampere was passed through it for one hour each time. At 18° C. I found the following values:

MANGANIN.

Date.	Resistance in Ohms.	Date.	Resistance in Ohms.
January 6, 1890.....	2.9998	July 22, 1891.....	2.9996
April 15, 1890.....	99	February 9, 1892.....	98
February 12, 1891....	98	July 17, 1892.....	96

Again, in the following table are stated in microhms the differences in the resistance of four manganin standards (No. 148 to No. 151) of one ohm. The numbers marked * were observed by Drs. Kreichgauer and Jäger, using Kohlrausch's differential galvanometer method, the others by myself, using a Wheatstone's bridge arrangement.

—	December, 1891.*	February, 1892.	July 1892.*	July, 1892.
No. 148-No. 149....	-121 X 10 ⁻⁶ Ohms.	-121 X 10 ⁻⁶ Ohms.	-117 X 10 ⁻⁶ Ohms.
-No. 150..	-135	-135	-129
-No. 151 ..	80	81.5	86
No. 149-No. 150 ...	14	14	12	- 16
-No. 151....	+ 41	+ 40	+ 31
No. 150-No. 151....	+ 51	+ 54	+ 43	+ 48

—	September, 1892.	September, 1892.*
No. 148-No. 149....	- 110
-No. 150....	-128
-No. 151....	- 90
No. 149-No. 150....	- 19	- 18
-No. 151....	+ 20
No. 150-No. 151	+ 38

Measurements were also made of these standards shortly after their construction in July, 1891, but not with quite the same accuracy as the later ones. Anyhow, they show, in connection with numerous comparisons of the four coils with other standards, which were checked by mercury resistances, that the manganin coils were constant for the space of two years within a few thousandths per cent.

For uncovered wires, as they are used, for instance, in bridges or in technical resistances, the manganin is not so appropriate as the alloys commonly used, because it would oxydize in high temperatures. For all other resistances, however, I think it is the best alloy hitherto known, because it facilitates the electrical measurements, and brings them to a higher degree of accuracy than was formerly attainable.

The time is too short to enter into the mechanical construction. Specimens of these resistances may be seen in the exhibit of the Physikalische Technische Reichsanstalt.

DISCUSSION.

THE CHAIRMAN :—We are now ready, gentlemen, for the discussion of Dr. Lindeck's paper.

MR. EDWARD WESTON, of Newark, New Jersey :—Mr. Chairman, I have listened with great interest to Dr. Lindeck's paper, embodying the results of his and his associates' work on alloys practically free from variation in resistance by changes in temperature, and am greatly pleased to find the results embodied in such form as will tend to increase the confidence of electricians in these alloys, and which will doubtless draw their attention more closely to the great value of these alloys in practical and scientific work.

From the title of the paper many may be led to infer that prior to the time of the work of the members of the Reichsanstalt the alloys referred to by Dr. Lindeck were unknown. This would be a mistake. The discovery of alloys having a negative temperature co-efficient, and also alloys having practically no temperature co-efficient and possessing the extremely valuable property of great stability, referred to by Dr. Lindeck, must be credited to America. In a measure Dr. Lindeck admits this, when he refers to my work on the manganese alloys, but as he does not appear to be aware of the extent of my work on alloys, I deem it proper and just therefore to reclaim at the present time the discovery of the properties of these alloys, and to bring to the attention of the members of this Congress a few facts concerning the extent of my work in this direction. You are all doubtlessly familiar with the classical work of Dr. Matthiessen on the subject of alloys for standards of resistance, and his earnest and prolonged search for metals or alloys possessing the greatest permanence and least temperature co-efficient, and, consequently most suitable for practical units of resistance. Among the simple metals none were found to possess the necessary qualities, and, as the result of this work, two alloys were found which appeared to possess, in a higher degree than any of the other alloys examined, the qualities most desirable for their use as standards of resistance, namely, a platinum-silver alloy; and an alloy of copper, nickel and zinc, commonly known as german silver. From the time of Dr. Matthiessen's researches in the sixties, up to a few years ago, these two alloys were practically the only ones used in resistance coils. Dr. Matthiessen strongly recommended the platinum-silver alloy for use in the better class of standards, on account of its lower temperature co-efficient and higher specific resistance, and also highly recommended the use of german-silver on account of its low cost and superiority to all other alloys, except platinum-silver, in point of higher specific resistance and lower temperature co-efficient. Now, as a matter of fact, Dr. Matthiessen was in error in regard to the higher specific resistance and lower temperature co-efficient of platinum-silver as compared with german-silver properly prepared. Ger-

man-silver is extensively used in the arts for the manufacture of hard metal table ware, and other purposes, but its composition is very variable, the percentage of nickel present in the lower grades varying greatly. I know of no german-silver being on the market as early as 1883 which contained more than 18 per cent. of nickel, and the bulk of the german-silver used in the arts at that time did not contain more than about 14 per cent. of nickel. From experiments made as early as 1883, I found that the electrical properties of german-silver were greatly affected by the amount of nickel present in the alloy, and made alloys of copper, nickel and zinc, which contained nearly double the amount of nickel commonly found in german-silver as found in the market. From these researches I established the fact that the specific resistance of german-silver increased as the percentage of nickel increased, and that the temperature co-efficient was greatly reduced by the use of a larger percentage of nickel in the alloy than was commonly used. In this way I succeeded in producing a german-silver nearly twice the specific resistance of Matthiessen's german-silver, and of a much higher specific resistance than platinum-silver, and having about the temperature co-efficient of the latter-named alloy. In May of 1886, Mr. J. T. Bottomley presented a paper to the Royal Society of London, entitled, "On the Electrical Resistance of a New Alloy named Platinoid." On reading this paper I was greatly impressed with the peculiar manner of making the comparison between the electrical properties of this alloy and german-silver. The statements made by Mr. Bottomley in the paper referred to, induced me to again examine, with greater care, the electrical properties of german-silver. I made a large number of alloys containing copper, nickel and zinc in different portions. I also made a series of alloys, in which the amount of copper and zinc was kept constant, but in which the amount of nickel varied from 12 to 34 per cent. The resistance and temperature co-efficients of these alloys, and a large number of other alloys containing the same elements in different proportions, were determined. Tungsten in the form of phosphide was added to some of the alloys, and metallic tungsten to others, and as the result of this work we found that the so-called "platinoid" differed in no respect in its electrical and chemical properties from the simple copper-nickel-zinc alloy, having the same percentage of nickel. In other words, "platinoid" was simply a fairly good grade of german-silver.

The results of these later, and more carefully conducted researches, confirmed my previous work, and led me to the conclusion that in german-silver alloys the effect of an increase in the percentage of nickel present, was to increase the specific resistance of the alloy in approximately *direct proportion* to the increased percentage of nickel, and, what was still more important, that the temperature co-efficient diminished in nearly direct

proportion (in these copper-nickel-zinc alloys) to the increase in specific resistance. Some of the results of some of these later researches were described, with more or less exactness, by one of my assistants, Mr. George B. Prescott, Jr., in an article written by him and published in an American Journal, *The Electrician and Electrical Engineer*, of April, 1886 (Vol. V, pp. 126-128.) I would like it understood that I took no part in the writing of the article referred to. Mr. Prescott simply asked my permission to publish such facts concerning the results of the investigations on the copper-nickel-zinc alloys, as would be of some service to electricians and electrical engineers, in determining the kind of german-silver best adopted for their various wants. I particularly cautioned him to say nothing concerning my researches on a large number of other alloys, which researches had been in progress for a long time.

In the latter part of the year 1884 I began a very extensive series of experiments on alloys, for the express purpose of finding, if possible, an alloy more suitable for resistance coils than either german-silver or platinum-silver. The three qualities needed were higher specific resistance, practical freedom from variation in resistance by reasonable variations in temperature, and greater permanency. Some 300 to 400 different alloys were made; in these, most of the more common metals and many of the rarer ones were employed. The investigation covered binary, ternary, and occasionally quaternary alloys, of the more common metals. It included alloys of copper and cobalt, copper and silver, copper and iron, copper and manganese, and nickel-copper manganese and cobalt, etc. Quite a large number of alloys were also made by combining the rarer metals with the more common ones. In these latter named alloys no new phenomena of interest to the electrician were observed; but with the nickel-copper, manganese-copper and nickel, some very interesting results were obtained, and, for the first time, alloys were found which had practically no temperature error, which were of extremely high specific resistance, and very permanent. But another most singular fact was observed, namely, that it was possible to secure alloys with a *negative* temperature co-efficient, or in other words, an alloy which was affected by changes in temperature, in direction just the reverse of all previously known metals or alloys. That is, the resistance decreased as the temperature increased. The decrease in resistance with increase in temperature was, however, very small; but it was sufficiently marked to be easily observable and of practical utility, by combining such an alloy with another having a positive co-efficient, and so neutralizing absolutely the effect of changing resistance in one alloy, in one direction, by an equal and opposite change of another alloy. I never found time to publish the results of these researches, further than is found in the specifications of the United States patents, issued to me several years thereafter. These patent

specifications disclose for the first time alloys with negligible temperature co-efficient, and alloys having a negative co-efficient. But if anyone reads these patents, it must not be assumed that the body of the specifications describes and deals with all the alloys made and investigated. It is a wise provision of the American patent system, which simply makes it necessary for the inventor or discoverer to describe only one means of carrying his discovery or invention into practical effect, and at the same time permits him to draw such claims as will protect him in the use of his discovery or invention, when other and similar means are employed of accomplishing substantially the same result.

At the time the specifications referred to were written, I had discovered the many excellent electrical qualities of the nickel-copper alloys, and was quite familiar with the influence of zinc in affecting the permanency of alloys. I had used various percentages of nickel and copper in the nickel-copper alloys, and was quite as familiar with the influence of an increase in the amount of nickel in these alloys, as I was with its influence in the copper-nickel-zinc alloys. I will state, however, that we found it extremely difficult to work copper-nickel alloys in which nickel was present, in amount exceeding 35 per cent., and this seemed to be a great drawback to the copper-nickel alloys, which were very rich in nickel. They appeared to be preferable to the manganese-copper, manganese-copper-nickel, the ferro-manganese-copper and the ferro-manganese-copper-nickel alloy in regard to their power to resist oxidation in the air. But we could secure a higher specific resistance, with the manganese alloys than we could with the copper-nickel alloys. The objection to the use of the copper-nickel alloys on account of their high thermo-electric power, is in my opinion, of little account; since the thermo-electric effects of such alloys, when used in standard resistances, can easily be eliminated in the majority of cases, by using the same alloys as terminals and conductors. The nickel-copper alloys also possess the advantage of being more easily made of constant composition, than the copper-nickel-zinc alloys, and unless great care is exercised in the preparation of the copper-manganese or copper-manganese-nickel alloys, it will be found more difficult to prepare these alloys of constant composition than the simple copper-nickel alloys. The copper-nickel alloys can also be made of much higher specific resistance, and with a vastly lower temperature co-efficient, than the very best german-silver that can be made. Moreover, the copper-nickel alloys are much more stable than the german-silver alloys. German-silver is a very treacherous alloy to use, even in common resistance coils. Many years ago I noticed a marked deterioration in the German-silver wire used in ordinary regulating rheostats used with dynamos. The german-silver wire used was of good quality, but after a few years use it became so fragile as to be incapable of withstanding the slight strain necessary to keep the spirals separate,

and became so brittle as to snap like a piece of glass. Longer use resulted in the wire becoming so fragile as to be easily crumbled with slight pressure between the fingers. I am inclined to believe, however, that this deterioration is the result of some action by the current; but further investigation is needed to confirm this opinion. My own confirmations fully confirm Dr. Lindeck's remarks concerning the unreliability of german-silver as a material for standard resistances. Prior to the publication by Mr. G. B. Prescott, Jr., of some of the results of my investigations of the electrical properties of german-silver, I believe that Matthiessen's value for the resistance and temperature co-efficient of german-silver was generally accepted and used by electricians, and I think it likely that many electricians still employ Matthiessen's values. For I notice that the values found by Matthiessen are still given as the correct ones in the text books I have examined, and, so far as I know, only one author refers to my work, and states the fact that the resistance of german-silver is depending upon its composition; and not one that I know of has given any other value for the temperature co-efficient of german-silver, except the value given by Matthiessen. Stewart & Gee, for example, give the resistance of a centimetre cube of german-silver as 21.17 microhms at 0° C., and the resistance of a similar cube of copper at 1.616. That is, the resistance of german-silver is nearly 13 times that of copper. The temperature co-efficient given for this german-silver is that given by Matthiessen, namely, .0004433 per degree centigrade. Now, as a matter of fact, I found copper-nickel-zinc alloys (german-silver) which had a resistance nearly 28 times that of copper, and a temperature co-efficient of about one-half that given by Matthiessen. I think I have said enough about the electrical properties of german-silver to make it clear that it is necessary to discard the values given by Matthiessen, and to assume no value for any given sample of german-silver, but to determine it for each case, or else to draw curves based upon the results of my experiments, showing the influence of variation in composition of the alloy on its resistance and temperature co-efficient.

In the nickel-copper alloys, as in german-silver, I found that the resistance increased with an increased percentage of nickel, and that the temperature-coefficient became less as the specific resistance increased. In fact, I found this latter statement to be generally true of all alloys. In some of them the temperature co-efficient became so extremely small as to be absolutely negligible, even in very close work, and tended to assume a very small negative value. Of all the alloys tested I found none which gave such extremely high resistance as those which contained manganese in combination with copper or iron, or manganese, copper and nickel. Indeed, I found it quite possible to make alloys with these metals, which had a resistance nearly 50 times that of copper, or about four times that of Matthiessen's german-silver,

and about double the resistance of the best copper-nickel-zinc alloys I was able to prepare.

In general, my determinations of temperature co-efficient of these alloys agree very well with the results given by Dr. Lindeck, but after I succeeded in securing alloys having the properties I needed, and publishing the fact of the existence of such alloys in the specifications of the patents, I felt that I had spent all the time I could on this laborious and long continued line of experiments, and did not publish in detail the full results of all the work done on them. I believe such facts as were set forth in the patents constituted a substantial contribution to the art of electrical measurement, and I fully expected that others would pursue the line of work disclosed. It affords me great pleasure to have Drs. Feussner and Lindeck confirm the substantial correctness of the work done, and still greater pleasure to find such able and careful investigators reach the same conclusions as I did in regard to the value of these alloys with practically no temperature co-efficient.

In connection with this matter I may say, that I made no effort to keep the results of my work on alloys secret after the applications for the patents. Indeed, I informed my friend, Prof. H. A. Rowland, of the results of the work in 1886 and 1887. I also remember very well reading an account of a lecture by Prof. Geo. Forbes, in which he referred to the fact that the only real distinction existing between metals and non-metals, was based upon physical reasons, and that was the property of all metals of increasing in resistance with rise in temperature; whereas, all non-metals had the opposite properties. Shortly after the delivery of this lecture Prof. Forbes visited America, and I told him that the difference he supposed to exist at the time of the delivery of his lecture did not in fact exist, but that there were metals, or, more properly speaking, alloys, which had the same properties as the non-metals, namely, that of showing a decrease in resistance with rise in temperature, thus again removing the last vestige of a line of demarcation between metals and non-metals. The original applications for the patents covering these alloys were sworn to on the 2nd day of October, 1885, and the applications were duly filed in the United States Patent Office on October 13th of the same year. The patents were not issued, however, until April 17th, 1888, and were re-issued shortly thereafter. The re-issued patents are dated July 17th, 1888, and numbered 10,944 and 10,945.

The claims of these patents fully cover such alloys as are referred to by Dr. Lindeck."

PROF. LANGLEY:—I should like to ask Dr. Lindeck what is the safe temperature, the limit at which the manganese does not oxidize?

DR. LINDECK:—It is one centigrade.

PROF. S. P. THOMPSON:—I will say I do not in the least doubt

the good work that has been done by Dr. Lindeck in the production and testing of these manganese alloys, but I have my misgivings as to whether or not a manganese alloy will really be satisfactory, for the reason that Dr. Lindeck has explained that the manganese constituents cannot be relied upon if by any momentary action the wire is hot. I have seen some resistances that, if carefully prepared, would render manganese entirely useless. Another point, I found that any alloy containing the metal zinc is absolutely unreliable. Brass wires are unreliable; zinc seems to have the curious faculty of getting through metals in a strange way. I will illustrate: If you take a copper wire and dip it in a zinc bath and plate it with a thin coat of zinc it looks like zinc, and when you put it in the open air the zinc seems to disappear, it looks like brass and then like copper. The zinc has penetrated the wire. It is clearly a metal that cannot be relied upon. Of course, if we are going to use standards by not using them and say we are going to brick them up in a wall and preserve them for a century, manganese will do to look at.

MR. WESTON:—I could hardly agree with Dr. Thompson in regard to the necessity of standing a temperature; in the use of manganese great care should be taken, they should not be allowed to get very hot. What would become of a mercury standard if it was raised to that temperature?

DR. LINDECK:—I agree with Professor Thompson, and I will say that manganese is of no use if there should be a large amount of current passing. I said so in my paper, what I said about manganese was only about standard resistance, and I agree with Mr. Weston that standard resistance must be carefully handled. You must avoid the passing of too large a current through it, and see that it is not heated to a considerable amount. The resistance suggested by Dr. Feussner is very well protected against chemical action, and if anybody is interested, he can have an opportunity of seeing this resistance in the German Section in the Electricity Building.

THE CHAIRMAN:—There is a second paper close at hand upon the programme upon a subject quite closely allied to this, and I am going to ask Mr. Kennelly to read his paper.

Mr. A. E. Kennelly then read the following paper:

SOME MEASUREMENTS OF THE TEMPERATURE VARIATION IN THE ELECTRICAL RESISTANCE OF A SAMPLE OF COPPER.

BY A. E. KENNELLY AND REGINALD A. FESSENDEN.

Precision in the determination of the temperature variation of resistance in copper is important not only to electrical science, but also to its applications. Our estimate of the temperature of remote or inaccessible positions, as, for example, the ocean bed on which a submarine cable lies stretched, or the interior layers of a dynamo armature winding are often directly dependent for their accuracy upon the completeness of our knowledge of this temperature coefficient.

Electrical text-books, in stating the temperature coefficients of copper, usually quote the results of Dr. Matthiessen, or of Dr. Siemens, or both.

The results of these two authorities are discordant.

Within the range of chamber temperatures, say from 0° C. to 35° C., the difference between is practically of little importance. Taking, however, the resistivity of copper at zero as unity, its resistivity at 100° C. is 1.422 by Matthiessen's observations, and 1.388 by those of Siemens, a variation of nearly $2\frac{1}{2}$ per cent., while above 100° C. or below 0° C., this discrepancy increases rapidly.

First in order of date are the elaborate researches of Matthiessen (and of his collaborator Von Bose), appearing in the *Phil. Magazine* for February, 1857, and February, 1861; also in the *Phil. Transactions* for 1858, 1860, 1862 and 1864, the most important series from our present standpoint being those for 1862. The wires tested were varnished with shellac,

and immersed in a bath of oil whose temperature was raised by the application of Bunsen burners, and read off by an immersed thermometer. Readings were taken both in ascending and descending series of temperatures, and observations are adduced in support of the statements that the application of varnish did not affect the results, and that the observations on a wire heated in a bath of oil were sensibly the same as when the heating took place in air. Matthiessen took six copper wires, all from the same electrolytic source, three annealed and three hard-drawn. Six observations are given of the resistances of each between 0° and 100° C. Having ascertained that all 36 observations accorded very fairly with a parabolic relation between conductivity and temperature, the parabola of closest conformity computed by the method of least squares was

$$\lambda = 1 - \alpha t + \beta t^2 \quad (1)$$

or numerically

$$\lambda = 1 - 0.0038701 t + 0.000009009 t^2 \quad (2)$$

λ being the conductivity at temperature t° C.

From this equation, the resistivity ρ (the reciprocal of λ), retaining the terms necessary for accuracy in the fifth digit at the limit of 100° C. becomes

$$\rho = 1 + \alpha t + t^2 (\alpha^2 - \beta) + t^3 (\alpha^3 - 2 \alpha \beta) + t^4 (\alpha^4 - 3 \alpha^2 \beta + \beta^2) + t^5 (\alpha^5 - 4 \alpha^3 \beta + 3 \alpha \beta^2) + \dots$$

$$\text{or } \rho = 1 + 3.8701 t \times 10^{-3} + 5.968 t^2 \times 10^{-6} - 1.177 t^3 \times 10^{-9} - 9.93 t^4 \times 10^{-11} - 2.79 t^5 \times 10^{-13} + \dots$$

For $t = 100$, $\rho = 1.4222$.

The graph of this equation, taking values of ρ as vertical ordinates from a horizontal axis of temperatures as abscissas, yields a curve bending upwards, so that the temperature variation increases with the temperature, the increase in resistance per degree Centigrade being at 0° C., 0.387 per cent., and at 100° C. 0.50 per cent. of the resistivity at zero C. Matthiessen points out that this bending upwards of the curve is distinctly indicated by his results, and that no straight line can represent them. Not only the 36 observations on copper wires, but more than 200 quoted observations on other metals, all point to a temperature coefficient augmenting with temperature and negative the supposition of a simple linear relationship between the variables.

Dr. Siemens' researches formed the subject of his Bakerian

lecture in 1871. They were undertaken with the object of obtaining a practically reliable scale for the electric pyrometer which bears his name, rather than for the direct purposes of scientific research. After pointing out that Matthiessen's formula can, on its own evidence, be only fairly applicable between the limits of 0° and 100° C., Dr. Siemens proceeds to advance some interesting, although arbitrary, hypotheses for the law of temperature variation in metallic resistances, and then shows that his experimental observations on copper and four other metals are capable of close representation by the empirical formula so obtained. These observations were made on wires heated in air, and also in oil, up to 350° C. with mercury thermometers, and in one series up to 850° C. with a platinum ball thermometer pyrometer, an instrument whose indications assumed a constant specific heat in the platinum ball throughout the range of temperature employed.

Dr. Siemens' formula for copper is

$$\rho = 0.026577 \sqrt{T} + 0.0031443 T - 0.29751$$

$$\text{For } 0^\circ \text{ C. or } T = 273, \rho = 1$$

where ρ is the ratio of the resistivity at any absolute temperature T , to that at zero Centigrade, or $T = 273$. For 100° C., or $T = 373$, $\rho = 1.3886$, and the rate of increase of resistivity is at 0° C., 0.394 per cent., and at 100° C., 0.383 per cent. of the resistivity at 0° C. The graph of the equation is a curve bending slowly downwards towards the axis of temperatures, and the temperature variation diminishes as the temperature rises. All the 170 observations recorded in the paper indicate that the curve bends downwards, while all the 250 observations in Matthiessen's 1862 paper make the curve bend upwards. The discrepancy between these two series of results becomes very noticeable between 70° and 100° C.

Professors Dewar and Fleming have published in the *Phil. Mag.* for October, 1892, a number of observations on the resistivity of metals and alloys at temperatures between — 200° C. and + 100° C., one series for copper being included. The resistivity of the copper wire is stated to have been 1353 c. g. s. units at 0.7° C., equivalent to 1349 at 0° C., and since Matthiessen's standard is 1594 at 0° C., this represents a conductivity 18 per cent. higher than Matthiessen's standard. Aside, however, from this remarkable and perhaps debatable statement, the graph

of the observed values of resistance with respect to temperature is very nearly a straight line throughout the whole range, the resistivity at 100° C. being 1.424 times greater than that at 0° C., and the temperature co-efficient being approximately 0.424 per cent. per degree Centigrade for all temperatures between — 200 and + 100° C.

Between 0° and + 93° C. their results give $\rho_t = \rho_0 (1 + 0.004235 t)$.
Between 0° and — 197° C. “ “ “ $\rho_t = \rho_0 (1 + 0.004406 t)$.

Messrs. Cailletet and Bouty, in the *Comptes Rendus* for 1885, give an observed temperature co-efficient for copper of 0.418 per cent. per degree C. expressed by $\rho_t = \rho_0 (1 + 0.00418 t)$, between zero and — 58° C., and 0.425 per cent. from — 69° to — 123° C.

In *Poggendorff's Annalen* for June, 1858, Herr Arndtsen quotes a uniform temperature co-efficient of 0.369 per cent. per degree from zero to 200° C. He gives, however, one series of observed resistances with a copper wire (containing 0.1 per cent. of iron) between 0° and 100° C., showing a linear relation, or a temperature co-efficient of 0.394 per cent. per degree C. $\rho_t = \rho_0 (1 + 0.00394 t)$, and he points out that the divergences from the straight line are within the limits of the observation error.

In view of the discrepancies existing between these best known measurements of the temperature co-efficient of copper, Arndtsen, Cailletet and Bouty giving results practically represented by straight lines, Siemens' results with the line bending distinctly downwards, and Matthiessen's results with the line bending as distinctly upwards, the writers of this paper made a number of measurements in the Spring of 1890 upon a sample of copper wire. These measurements were made with great care, and repeated until similar results were obtained in successive series. The wire tested was sealed within the bulb of an air thermometer, so that there could be no appreciable variation between the temperature of the wire itself and the temperature indicated by the pressure of the air in the bulb it occupied. The final results after full corrections for expansion of the bulb, etc., indicated a linear relation between the resistance and temperature of the wire between the limits of 20° C. and 250° C. represented by the equation $\rho_t = \rho_0 (1 + 0.00406 t)$, indicating a uniform temperature co-efficient of 0.406 per cent. per degree Centigrade throughout that range, the maximum observed being 0.4097 per cent. and the minimum 0.399 per cent. at any point. The details

of these measurements are here submitted in the form of an appendix, not only in support of the statements made concerning them, but also because the experimental arrangements of apparatus, finally successful, were the outcome of a series of experimental failures, and it is believed that the details of construction may be of service to those who desire to adopt the same method of measurement.

Concerning the conclusions that may be drawn, we feel only justified in saying that copper can be found in which a linear relationship holds between resistance and temperature between 20°C . and 250°C ., and within the range of small observation errors. It is of course possible that in different samples of wire, the temperature coefficient may increase or diminish with the temperature, in other words the second differential coefficient of resistance with respect to temperature may perhaps in some samples be either positive or negative, but it seems desirable that fresh measurements should be made, and evidence collected to settle this point, and we submit the view that the best experimental means of measuring the temperature, and to ensure the coincidence between the measured temperature and that of the tested wire, is to enclose the latter in the bulb of an air thermometer in the manner here described.

NOTE ON THE TEMPERATURE OF LOWEST VISIBLE RED HEAT.

A few measurements were made of the resistance of copper wires enclosed in exhausted glass tubes and gradually raised to just visible red heat by gradually increasing the current strength through them. The tubes were 30 cms. long, and 2 cms. external, 1.8 cms. internal diameter. Two platinum wires were sealed into the glass at each end and connected with the copper wire, one to carry the heating current, and the other to act as "pressure wire" in order to eliminate the resistance of the first, or platinum electrode. The copper wire stretched along the axis of the exhausted tube was 30.4 cms. long and 0.0015 in. (0.0038 cm.) in diameter.

Measuring the resistance of these wires at normal temperature with a very feeble current, they were then raised to redness and their resistance observed under that condition in a darkened room.

Reckoning back with the linear temperature coefficient of 0.00406 from the normal temperature to zero Centigrade, the

resistance of the wire was found to be three times that at zero when visible luminosity was just attained, the mean calculated ratio being in fact 3.001. If the same linear temperature coefficient be assumed throughout that whole range, the corresponding temperature of lowest visible luminosity becomes 493° C. in this instance.

The method is very sensitive in application, and repeated trials with the same wire and same observer would usually fall within two degrees Centigrade by resistance valuation. There was, however, a systematic variation between the observations when the observers were exchanged, amounting to about three degrees Centigrade, and since the criterion of appreciable visibility is merely physiological, it is perhaps impossible to accurately define it. From the sensations experienced in observing, it might be supposed that habit or physical condition might appreciably influence the range of visual appreciation, after the manner of a personal equation.

In conclusion, we desire to express our acknowledgements to Mr. Thomas A. Edison, in whose laboratory the above research was conducted.

APPENDIX.

1ST.—GENERAL OUTLINE OF APPARATUS.

Within the cylindrical glass tube of an air-thermometer was enclosed about 240 cms. of fine copper wire. Short platinum wires, sealed into the glass bulb brought this copper wire into communication, with apparatus for measuring its resistance. The bulb rested in an oil bath heated electrically, and the height of a mercury column required to balance the pressure of the internal air, was measured by a cathetometer, at the moment that the resistance of the copper wire was noted. The bulb was thus operated as an air-thermometer at constant volume, and corrections were applied to the expansion of the glass walls of the bulb, and for the variation of barometric pressure during the period of observations, also electrically for the resistance of the leads up to and including the platinum seals.

THERMOMETER BULBS AND CONTENTS.

A vertical section of the thermometer bulb and its accessories is shown to one-third true scale in Fig. 1. A B is the cylindrical glass bulb 15 cms. long, and 3.15 cms. external, 2.85 cms. inter-

nal diameter. The capacity of the chamber so enclosed was approximately 75 c. c. Three separate platinum wires 2 cms. long and 0.048 cm. in diameter were sealed in at D and welded with three exterior copper wires, E F and G, forming the leads to

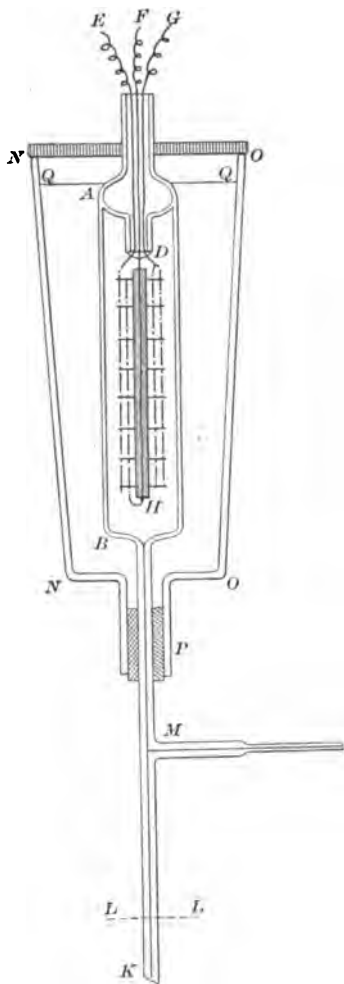

Fig. 1.

the apparatus. The central wire was also welded within the bulb to a copper wire 10 cms. long and 0.08 cms. in diameter, and the seal supported this wire axially along the bulb to its termination at H.

This copper wire, D H, was entirely covered by a glass tube 10

cms. long and 0.25 cms. in external diameter. Closely threaded on the glass tube were beads or short cylinders cut from glass tubing, each bead being 1 cm. long, 0.28 cms. internal and 0.4 cms. external diameter. The beads served as sleeves or washers to clamp between them at their junctions circular disks of mica 1.9 cms. in diameter and 0.02 cms. thick, with a hole in the centre 0.25 cms. in diameter. Two circles of holes were drilled concentrically around this disk, each circle having fifteen holes. The diameter of these circles were 1.0 and 1.65 cms. respectively. A plan view of a mica disk is shown at Fig. 2, to full scale.

The copper wire tested was of good commercial quality 0.002 in. (0.0051 cm.) in diameter, and double silk covered. The silken covering was dissolved off with hot caustic soda, diluted so as not to oxidize the wire, and the bare wire threaded up and down through the mica disk, and parallel to the axis of the bulb, first filling up the inner cylinder of holes and then the outer. The inside end was soldered to platinum wire No. 1, connected with the lead ϵ , the final exterior end soldered to platinum wire No. 2 from lead α , and the junction or midway point connecting the inner and outer cylinder was connected to the copper wire at

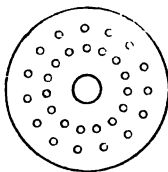

Fig. 2.

which communicated with lead ϵ . By this means two separate loops of wire, of nearly equal length, were provided within the bulb, arranged in two cylinders, one within the other. The outer cylinder between leads ϵ and α had a diameter of 1.65 cms.; the inner, between ϵ and ϵ , a diameter of 1.0 cms. The object of this arrangement was to furnish a check by duplicate, upon the observed resistance of the tested wire, and also to ascertain what difference in temperature, if any, existed between the air at radius 0.5 cm. and the air at radius 0.8 cm. from the axis of the bulb, the source of heat being entirely external. Had the mean temperature of the inner and outer cylinders differed at any time in virtue of gradient of temperature within the bulb, by one tenth of one degree centigrade, it would have been within the range of observation; and had it amounted to one-fifth of a degree, it could not have escaped detection. No appreciable difference was at any time discovered, the increase of resistance in the two cylinders being always proportionally co-incident, so that finally the two loops were combined into one for facility in observing and only divided for an occasional check. The diffu-

sion and convection of the air within the bulb must have been sufficiently rapid to practically equalize the temperature within the air space. The course of the wire within the bulb is indicated by the dotted lines in Fig. 1.

The bulb communicated with the mercury through a glass tube DK ; the diameter of this tube was 0.6 cms. externally and 0.1 cm. internally, and the volume of its bore from bulb to fiducial mark, including the offset tube at M , was 0.3 c. c. or $\frac{1}{30}$ of the volume of the bulb.

The bulb was held vertically upon the axis of a glass percolator $NNOO$, the lower tube passing through a rubber stopper at P . The space between the bulb and walls of the percolator was filled with boiled linseed oil up to the level QQ , and a cylindrical grid of platinoid wire, not shown in the figure, was immersed in the oil. A steady current of from two to three amperes through this platinoid wire of 16 ohms resistance, served to raise the temperature of the oil and immersed bulb at a convenient rate. A disk of asbestos cloth, NO , rested as a cover upon the percolator, and more of the same material was wrapped around the exterior surface, $NNOO$, in order to impede the escape of heat from the chamber.

The following is a general description of the apparatus. A vertical wooden board, rising above a wooden trough set to catch any mercury that might escape, supports a long vertical tube in front of the cathetometer. A bottle of mercury and an equilibrating bottle of sand are supported by a cord running over pulleys fixed into the ceiling. Lowering the sand bottle raised the bottle of mercury and attached rubber tube, bringing the level of mercury in the index tube (allowing for capillarity) up to the same elevation.

ELECTRICAL MEASURING INSTRUMENTS.

The resistance of each cylindrical loop of wire within the bulb was about 10 ohms at the normal or initial temperature, in the vicinity of 20° C. making 20 ohms in all, and at the highest temperature reached in the measurements, these resistances doubled, so that the total range of observed change in resistance amounted to 10 ohms in each loop, or 20 when the loops were in series.

In the first trial, the resistances were measured by Wheatstone's bridge. This method was found to be unsatisfactory, both in respect to swiftness and precision. In swiftness, because the readjustment of the balance required some seconds to effect, and during that time the temperature of the wire might have altered; and in precision, since the resistance of the leads had to be subtracted, and these were likely to vary appreciably with the temperature of the room.

Later, two differential galvanometers were employed. One balanced the two loops within the bulb against each other to detect variations of temperature within the bulb, and the other compared the resistance of both loops in series against a fixed standard in platinoid wire (30 ohms).

Finally, the first galvanometer fell into disuse, since no variation could be detected between the resistances of the two loops, and measurements were confined to the second differential galvanometer, with one Wheatstone bridge reading as a check at the outset, and another at the culminating temperature of the series.

The differential galvanometer method is very convenient for such measurement. It enables the variations of the tested resistance to be constantly watched, and balance can be quickly readjusted with a dead beat instrument by rheostat thrown into the circuit of preponderating influence.

The main circuit consisted of the bulb with its two loops in series, a standard resistance of 30 ohms in platinoid, and an additional resistance of 50 ohms in a rheostat. A single Edison-Lalande cell delivered a steady current of from 6 to 7 milliamperes through this circuit. The two coils of the differential galvanometer had about 2,700 ohms each, one was connected to the terminals of the standard 30 ohms, and the other to the terminals of the bulb. A change of resistance in circuit of either coil, amounting to 1 ohm, could be plainly observed on the scale.

MODUS OPERANDI.

The bulb was repeatedly exhausted through its attached tube, then heated to 200° C. under a vacuum for an hour to expel all moisture, and finally filled with dried air. It was then tightly connected with the mercury apparatus and index tube by double rubber pipes well jointed. The offset tube was opened through a chamber containing calcium chloride so as to acquire internally the pressure of the air, which was noted by a mercurial barometer. The level of the mercury was raised at the same time to the fiducial mark, the temperature of the oil bath around the bulb observed, and the resistance of the enclosed copper wire measured. The temperature of the air close to the index tube was also taken. The offset tube was then sealed off with a blow-pipe, and the circuit of the platinoid grid in the oil bath closed. The level of the mercury was then raised in the index tube about 3.5 cms. to cathetometer observation, by lifting the mercury bottle through that distance, driving mercury into the bulb tube above the fiducial mark. The increasing temperature and pressure of the air within the bulb slowly forced the mercury in this column back to the fiducial mark, leaving the index elevation practically unaltered. At the moment that the mercury crossed the fiducial

mark, the resistance for balance at the differential galvanometer was noted. The level of the mercury in bottle and index tube would then be raised again another 3.5 cms., the mercury column elevated above the fiducial mark, the cathetometer reading taken and the resistance balance when the mercury again crossed the line. This process was repeated step by step until the maximum temperature was reached. Meanwhile readings were kept of the barometer pressure in the room, and the temperature of the air by the side of the index tube.

No appreciable time lag existed in the bulb, owing to a small thermal capacity. After the highest desired temperature had been attained in a series, the differential galvanometer would indicate a lowering in the resistance of the copper wire, within ten seconds of the interruption of the heating current. The reduction in temperature could be detected electrically ten or fifteen seconds before the mercury could be observed to retreat. This lag in the mercury was traced, principally, at least, to the influence of fluid friction in the narrow tube. Tapping this tube with the finger was found to accelerate the mercurial movement. Later the bulb tube whose internal diameter was 1 mm., in order to have as little volume of unheated air-space as possible, was welded into one of larger caliber (2 mm.) just above the fiducial mark, increasing volume of air-space outside the bulb to 0.4 cc., but materially diminishing the fluid friction, so that tapping the tube was scarcely necessary.

A similar series of cathetometer and resistance readings was obtained as the oil bath and bulb cooled down. An entire set of observations generally lasted four hours.

The mercury employed was filtered and kept clean. The internal diameter of the index tube was 0.6 cm., but as its capillarity error entered equally into all the readings, no correction was required on this account.

The co-efficient of expansion of the glass forming the bulb was measured by taking two globes blown from the same tubing as the bulb, drawing out their necks to a fine bore, filling them with a measured mass of mercury, at normal temperature, heating them up to their necks in mercury over a sand bath to 157° C. till they ceased to overflow, and the mass of mercury remaining was observed after cooling down.

The mean cubical expansion of the glass so determined was $3 B = (2800 \pm 113) \times 10^{-8}$, and this value was assumed in all voluminal corrections.

RESULTS.

The first four series of observations were rejected. When computed and plotted, with ordinates of resistance to abscissas of temperature, they showed curves bending slightly upwards, after the manner of Matthiessen's, but the descending curve was distinctly below the ascending branch, so that the diagram ap-

peared to form a loop as though the wire had a lower resistance for a given temperature when cooling than when heating. The cause of this error is not known, but may have been due to fluid friction of the mercury in the bulb tube. With each successive series the curvature of the line diminished, the ascending and descending branches approaching one another. The fifth series was considered to be satisfactory. Its graph is practically a straight line with a slight divergence between upward and downward branches. The reduced observations are given in the accompanying table I.

—	Temperature ° C. by Air Thermometer.	Linear Coefficient per ° C.	Weighted Mean.	Discrepancy.
.....	29.8	0.004037	0.004059	0.000022
.....	67.0	0.004076		0.000017
.....	79.8	0.004066		0.000007
.....	92.9	0.004085		0.000026
.....	104.7	0.004063		0.000004
.....	118.0	0.004055		— 0.000004
.....	131.4	0.004052		0.000003
.....	143.0	0.004058		— 0.000001
.....	155.0	0.004081		0.000022
.....	168.6	0.004087		0.000028
.....	181.7	0.004110		0.000051
Maximum	196.2	0.004084		0.000025
.....	199.0	0.004062		— 0.000003
.....	135.3	0.003999		— 0.000064
.....	123.6	0.003995		— 0.000049
.....	108.0	0.004010	— 0.000049	
.....	92.0	0.004017	— 0.000042	

The sixth series appeared to be the most reliable. Its graph is also practically a straight line up to the maximum temperature of 255° C. with no appreciable deviation between the ascending and descending branches, the latter being carried in this instance no lower than 207° C. The reduced observation referred to linear coefficients are given in the following Table No. II.

—	Temperature of Copper Wire in ° C.	Linear Coefficient of Increase per degree.	Weighted Mean.	Discrepancy.
.....	27.8	0.004007	0.004065	— 0.000058
.....	42.64	0.003984		— 0.000081
.....	56.55	0.004038		— 0.000027
.....	72.25	0.004027		— 0.000038
.....	87.11	0.004063		— 0.000002
.....	105.07	0.004172		0.000107
.....	123.99	0.004080		0.000015
.....	139.48	0.004141		0.000076
.....	154.17	0.004143		0.000078
.....	169.94	0.004082		0.000017
.....	183.71	0.004028		— 0.000037
Accidental fall in temperature	181.68	0.003968		— 0.000097
.....	197.03	0.003990		— 0.000075
.....	215.53	0.004022		— 0.000043
.....	230.59	0.004022		— 0.000043
.....	244.87	0.004049	— 0.000016	
.....	255.26	0.004070	0.000005	
Maximum	255.26	0.004074	0.000009	
.....	255.26	0.004088	0.000023	
.....	235.44	0.004097	0.000032	
.....	207.52	0.004088	0.000023	

Between the fifth and sixth series the apparatus was taken apart, the mercury re-filtered, the bulb re-exhausted and then re-placed. The method of measuring the temperature of the copper wire here described and advocated involves considerable more arithmetic labor in computing the results, owing to corrections for barometric pressure, temperature of the mercury column in the index tube and expansion in the bulb, but it eliminates all doubt as to the co-incidence between the temperature of the wire and the temperature indicated by thermometer, and avoids all differences between the true thermometric scale by air thermometer based upon Boyle's law, and the slightly divergent scale of the ordinary thermometer based upon the expansion of mercury.

TESTS OF THE COPPER WIRE USED.

The resistivity of the wire in the bulb was observed to be 1657 c. g. s. units at 0° C, from its mass and resistance, allowing a specific gravity of 8.90. Several different observations did not agree very closely, however, owing probably to the small diameter of the wire, and its liability to become stretched and variable in diameter.

An analysis of the copper wire used was made by Mr. McCoy, of the Purdue Chemical Laboratory. The results are as follows:

Antimony }	Less than .01 per cent.	More than .0025 per cent.
Arsenic }	" "	" "
Iron.....	" .025 "	" "
Zinc.....	" .08 "	" "

Owing to the fact that the well recognized methods of determining the above impurities are no longer accurate when applied to very small quantities of the foreign substance as in the present case, it was usually only possible to determine a superior limit which the quantity of impurity present could not exceed, but below which it might fall to any extent. In a few cases, however, an inferior limit was found. The results were checked by applying the same tests to a sample of copper prepared from electrodeposition with great care, and to which known quantities of impurities were added.

DISCUSSION.

THE CHAIRMAN:—The paper is open for discussion. I should like to ask one question myself, and that is, what was the color which the various observers noted, if any, at the beginning of incandescence, what did they call it?

MR. KENNELLY:—Red.

THE CHAIRMAN :—The reason I asked was that in some experiments made by a few of my students they called it gray. I never observed it myself.

MR. PREECE :—I should like before you close this discussion, to be allowed as a representative from the other side of the water, to express not only our obligations, but our admiration for the manner in which Mr. Kennelly and his collaborators are attacking this question. Personally I feel a very great interest in it because it is a subject that I have myself attacked and I only gave up the further study of the subject when I found that younger and abler men were taking it up on this side of the water.

I want to point out to Mr. Kennelly that at Cambridge where the question has been also carefully considered the discrepancy between the curves of Matthiessen and Siemens and also the discrepancy that is to be found in the text books and in papers generally as to the specific resistance of copper is attributable to a difference of density. It has been found by reference to Matthiessen's original papers that he used copper having a density of 8.9. At Cambridge they have been using copper which had a density of 8.946, and it was found that with the copper at this density the difference in the specific resistance formed a direct ratio between these two numbers. The numbers I happened curiously enough to have amongst my papers, a note that I took when Mr. Fitzpatrick read a paper on the matter at one of the meetings of the British Association, I think it was at Edinburgh, and the figure there given for copper at 8.946 specific gravity and 18 degrees Centigrade was 1754 and for copper at 8.9 density, and the same temperature the specific resistance was 1766. I remember after that working that down with a co-efficient, the co-efficient, then given for temperature, and I think if Mr. Kennelly will be kind enough to take that note and will apply to it, the formulæ derived from his experiments with his revised co-efficient that we shall find there will not be much discrepancy between the figure used in England and that used here. On the other hand we shall all be delighted to feel that we have a co-efficient derived from the unique means that Mr. Kennelly has in his possession and I can assure him as a representative of English electricians the result of his paper will be for us to accept his co-efficient without the slightest hesitation.

MR. KENNELLY :—Mr. Chairman, I think I have nothing more to say upon this matter except to add that I cannot accept the compliments that Mr. Preece has showered upon me even if I share them with my collaborator. I do hope that the results here offered may be the means of drawing attention to a very important subject practically and theoretically, and that further observations may be made by which we can settle finally the matter within reasonable limits of accuracy. I do not suppose one measurement can give them or one series can give them, but

I think a number of such measurements by five or six disinterested and unbiased observers may give us a result. I think that the method which we are undertaking is a very reliable one.

THE CHAIRMAN :—The next paper to be read is by Professor B. F. Thomas on photometric measurements.

Professor Thomas addressed the Section as follows :

NOTE ON PHOTOMETRIC MEASUREMENT.

BY PROF. B. F. THOMAS,
Ohio State University, Columbus, Ohio.

The observations which I have to make at the present time are theoretical in character. Unfortunately the experimental work which I have been doing in connection with the points involved in it, is not in such shape that I can present to you definite results; still the difficulties which I have encountered in the photometric work leading up to the present notes, lead me to think that some of the assumptions which have been made regarding the conditions governing photometric work need a little closer look into than they have so far received.

The law which states that the intensity of illumination produced by a radiant varies inversely as the square of the distance from the radiant, we are all, of course, familiar with, but any who have attempted to do close work upon the basis of that law have, as many writers have noted, found deviations from the results which should have been found if that law had applied in the given conditions. These deviations have usually been attributed to the fact that the radiant is not a point but a surface or a volume, but the conditions under which radiants used as standards, as well as radiants which are being measured, are used, are somewhat different from those usually assumed in the discussion of the theory; and for the purposes of what I have to say to-day I limit the consideration to radiants enclosed in clear glass envelopes.

It has been noted frequently that it is necessary in using as a photometric standard a burner having a glass chimney, that one should choose a chimney whose walls are parallel surfaces in

front of the flame, so that lenticular action of the glass may be avoided. I do not remember to have seen, however, that anyone has called attention to the influence of the part of the chimney which lies back of the flame, in other words reflection from the chimney itself. A figure will bring out more clearly the influence which must result from that.

If the arc AB be taken as a part of the inner surface of the chimney, and c as its center of curvature, it, as a cylindrical



FIG. 1.

mirror, must have its principal focus, for a limited portion of the surface, at D , half way between the surface and c . If the flame be at D , that part of its radiation which is reflected from AB will form a beam which is parallel in the horizontal plane, but which in the vertical plane diverges from a virtual focus D' , back of the chimney. Neglecting the action of other parts of the chimney, a surface s at the right of c will have an illumination made up of two parts. The first part is due to direct radiation from D , and is inversely proportional to the square of the distance Ds .

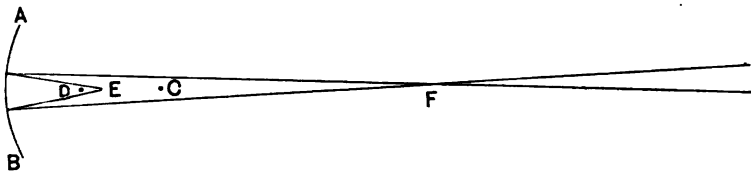

FIG. 2.

The second part is due to the reflection from AB , and is nearly inversely proportional to the distance $D's$. It follows that the total illumination can not vary inversely as the square of the distance Ds .

If the flame, or other radiant, be at some point between c and D , Fig. 1, instead of at D , the action changes to that shown in Fig. 2.

The light reflected from the surface AB converges, horizontally,

to a focal point *F*, conjugate to that occupied by the radiant *E*. For certain distances of *E* from the principal focus *D*, it will follow that that part of the illumination of a surface which is produced by the reflected light, will be greatest when the surface is at *F*, and will be less, if the surface be moved either toward or away from the radiant.

In Fig. 3, the curve *A B* is plotted to represent the illumination (ordinates) produced at different distances (abscissæ) by direct radiation. *C, P, D* represents the variation due to reflection, for the case supposed in Fig. 2. The curve *G, K, H* then shows the total illumination at like distances. Evidently the amount of distortion of the theoretical curve *A, B* will vary with the reflect-

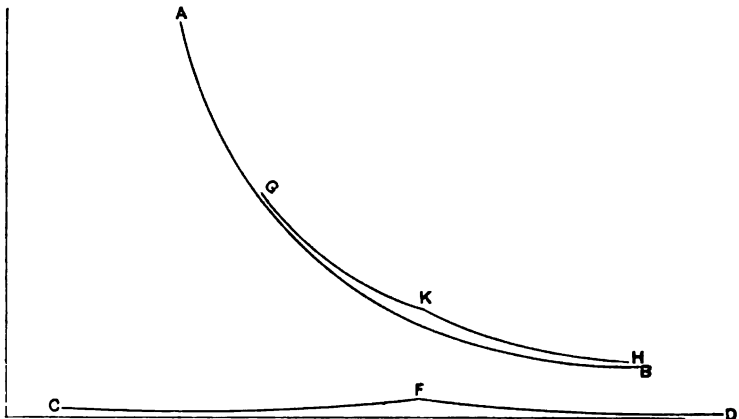

FIG. 3.

ing power of the glass chimney surface, and with the distance of the conjugate focal point *P*, from the flame. It is possible to produce conditions which will cause the total illumination to increase with increasing distance, in a limited part of the curve.

The simple case supposed is discussed to bring out as clearly as possible the effect of reflection from the chimney. The conditions existing in an argand burner, open or screened, are of course much more complex. The cylindrical form of the flame, cylindrical aberration, multiple reflections, and irregularities in the glass surface, all complicate the action so much that it seems useless to occupy your time with a complete discussion of them.

To learn whether the reflected light alluded to is of importance in photometric work, I have recently had an incandescent

lamp measured against a Methven standard, in the photometer which is to be used in tests of incandescent lamps at the World's Fair. Measurements were first made in the usual way, with the glass chimney of the Methven clean. Then the chimney was taken off, its rear half smoked until opaque, and replaced. The measurements of the incandescent lamp were then repeated. This was done a number of times, by different observers, who found a nearly constant difference of nine per cent. between the results obtained with the chimney clean, and those obtained with the chimney blackened. This result clearly makes it unsafe to neglect the action under consideration, when one wishes to do accurate work.

The only safe way in which one may use an argand flame as a working standard is to let its distance from the photometer disk be fixed, making variable the distance from the disk to the light which is being measured. If this cannot be done, the working standard may be improved by substituting for the glass chimney a metal one, its rear half thoroughly smoked and the aperture in its front surface covered by a thin piece of clear mica to avoid lenticular action. If the rear half of the metal chimney be flat instead of concave, it will be still better, for even the best black surfaces reflect some light.

The action under consideration has an important bearing on the photometry of incandescent lamps. If one looks at such a lamp when burning, a phantom filament will be seen, as well as the filament itself. The phantom is produced by reflection from the glass globe. A moment's consideration will make it clear that the phantom behaves as an independent source of light in illuminating the surrounding of the lamp. If the lamp be viewed from different directions, the phantom changes position and brightness, being excessively bright in some positions, and disappearing in others. If such a lamp be taken near a white wall, it will generally be noticed that the light falling on the wall is not uniform, but shows one or more streaks or bands of much greater brightness than the general surface. How is the average candle power of such a lamp to be determined, even in a plane perpendicular to its axis? The usual method of determining the mean horizontal candle power of a lamp is to take readings in several directions about its axis, most commonly in positions 30° apart, and to average the candle powers found in the several positions. This proceeding is based on the assumption that the

curve of actual intensity in all directions coincides with a smooth curve drawn through the values and positions observed. This can only be true when the angular settings are numerous enough to obtain the true form of the curve in regions where the light shows the streaks alluded to. Settings 30° apart will certainly not give the true value. It is questionable whether settings 5° apart will answer. By way of illustration it may be stated that a certain lamp, when under observation in the usual way, gave an average horizontal candle-power of about 14 candles. The highest value found in any one of the twelve positions used in getting the average was less than 16 candles. But a bright flash was noticed by the observer of the disk, when the lamp was being turned from one position to the next, 30° from it. The lamp was turned to the position giving the flash, and was found to measure 25 candles in that direction. If one could spin the lamp at sufficient velocity to produce visual continuity at the disk, a true average would be found.

Incandescent lamps are often used as working standards. Leaving all other questions as to their fitness for such use aside, if used at all, they should be carefully selected and tested with respect to the reflection error. To reduce this source of error as much as possible, the filament should occupy the least possible space and be placed as nearly as possible at the center of the bulb, which would be spherical and quite large. The reflected light will then proceed as if emitted close to the filament itself.

On motion the discussion was postponed until the following morning, and the Section thereupon adjourned.

THIRD MEETING, THURSDAY, AUG. 24, 1893, 10 A. M.

Section B was called to order at 10.05 A. M., by the chairman, Prof. Cross; and the minutes of the preceding meeting were read and approved.

THE CHAIRMAN:—The paper read yesterday by Prof. Thomas is now open for discussion.

MR. CARL HERING, of Philadelphia:—I would like to ask Prof. Thomas if he has any means to suggest to avoid that reflection in case of a bulb of an incandescent lamp where you cannot get inside?

PROF. THOMAS:—No. I do not see how that can be done.

PROF. G. W. PATTERSON, of Ann Arbor, Mich.:—It seems to me this last thing can be explained in another way, although

what Prof. Thomas says is undoubtedly true to some extent. If a light is placed in a room with walls of any reflecting power at all, the illumination is re-enforced by the reflection from the walls. If the walls are transparent also, as in the case of the glass chimney, part of the light emitted will have been reflected inside the chimney one or more times. This latter part of the light whether it obeys the law of inverse squares or not, is lost if the inside of the chimney is blackened.

THE CHAIRMAN:—Are there any further remarks?

PROF. THOMAS:—I did not hear Prof. Patterson's question. Will he please repeat it?

PROF. PATTERSON:—My idea is that with the ordinary chimney the whole of the light is not emitted at once, some of it being first reflected at the surface of the glass. It seems to me that we would get a smaller amount of light with the chimney than without it because of reflection and absorption and this amount would be much reduced if we had to lose, by absorption at the blackened surface, all of the light not immediately emitted.

Whether the portion of the emitted light which has been reflected within the chimney, will obey the law of the inverse squares of the distance from the Methven screen, seems to me to be a question which must be solved by measurements at various distances.

THE CHAIRMAN:—Are there any further remarks to be made? If not I will say that it is my impression that the hump to which Prof. Thomas refers is not universally present in the curves of incandescent lamps when the Methven slit is used. I should also like to ask Prof. Thomas whether the method of obtaining the average horizontal intensity of an incandescent lamp by whirling the lamp has any practical value. I have some interest in the matter because so far as I know it was originally suggested by me at the Franklin Institute Congress in 1884. The same idea also occurred to Prof. Wead. The difficulty expected was distortion of the filament from centrifugal force.

PROF. THOMAS:—It is quite true, as Prof. Patterson states, that a part of the light from the flame is reflected two or more times before passing out of the chimney to the disk. I have already alluded to this fact as multiple reflection. Such light, of course, adds to the illumination produced by the light which passes directly from the flame to the disk, and by that which is reflected once only, from the rear surfaces of the chimney. The illumination produced by it is so small that its effect may be neglected, in comparison with that produced by the first reflection, which has been under consideration. If we assume that ten per cent. of the light is returned from the glass at the first reflection, only ten per cent. of that ten per cent., or one per cent. of the original beam is returned at the second reflection. No serious error arises then from neglecting multiple reflections. Blackening the rear half of the chimney removes the disturbing influence of all reflections at once.

In reply to Prof. Cross, the form of the resultant intensity-distance curve (as α , κ , η , Fig. 3) obviously depends upon the reflecting power of the glass chimney and upon the relative diameters of the chimney and the flame. The curve given by one chimney and flame may be quite different from that given by another chimney of different diameter, used with the same flame. Indeed a simple displacement forward or backward, of the same chimney, will change the curve. For example, the curve corresponding to the case supposed in Fig. 1, will have no hump in it, like that at κ in Fig. 3. It will be a smooth curve not differing much in form from the theoretical curve, but having materially different values.

From experience, I am confident that the reflection error is the cause of many discordant results, and may in large part account for the different results found in measuring given radiants on photometer bars of different lengths.

I have had no experience in spinning lamps. The difficulty spoken of by those who have tried it, is the bending of the slender filaments, by centrifugal action when spinning. The method would be better adapted to lamps with anchored filaments, or with such short stout filaments as those of the Thomson-Houston and Bernstein series lamps.

THE CHAIRMAN :—The next paper to be read is by Prof. H. S. Carhart on "A Pair of Electrostatic Volt Meters."

Prof. Carhart then read the following paper:

A PAIR OF ELECTROSTATIC VOLTMETERS.

BY PROF. H. S. CARHART,
University of Michigan, Ann Arbor, Mich.

It is often desirable to be able to measure directly the potential difference between the primary wires of an alternator without recourse to a transformer or other auxiliary device. An electrostatic instrument is especially applicable to this purpose since it has no self-induction and takes no current. Such an instrument for laboratory purposes, which has proved exceedingly satisfactory, I have had made by my mechanician, Mr. Ralph Miller.

But another one, capable of measuring from about 20 or 25 volts up to 100, is needed for the purpose of calibrating the first. This I have also designed, and Mr. Miller has built it with much skill.

Both of these instruments may very properly be called electrostatic dynamometers. Each contains a mirror from which a beam of light from a lamp is reflected to a fixed scale; and in using them the spot of light is brought back to the initial or zero position by turning the torsion head before the reading is taken. The beam of light, some 40 inches in length, takes the place of the pointer of a Siemens' dynamometer. In this particular I have followed Mr. Swinburne, but in most other respects the design differs from his. In fact, I had never seen a Swinburne voltmeter till after my first instrument was made, and my second one differs from his more than the first.

Referring to Fig. 1, which consists of a horizontal and a vertical section, it will be seen that the fixed portions of the electrical device consist of four half circular flat boxes, three inches in diameter and half an inch deep inside. The lower pairs are

supported on ebonite pillars, and the upper ones are supported from the lower by means of lead glass rods set into appropriate sockets. The needle consists of two half circles of very thin aluminium mounted on wire of the same metal, as shown in the small diagram in the lower left-hand corner of the figure. It is evident that when the half circles are cross-connected, as shown, and one pair of inductors is connected with the needle, the forces acting on the movable system are all such as to turn it in one direction. The needle is suspended by a phosphor-bronze wire about 0.0015 inch in diameter from a torsion head of brass with a hard rubber top. The hole through this brass head is larger than the drawing shows, except at its upper end; so that the

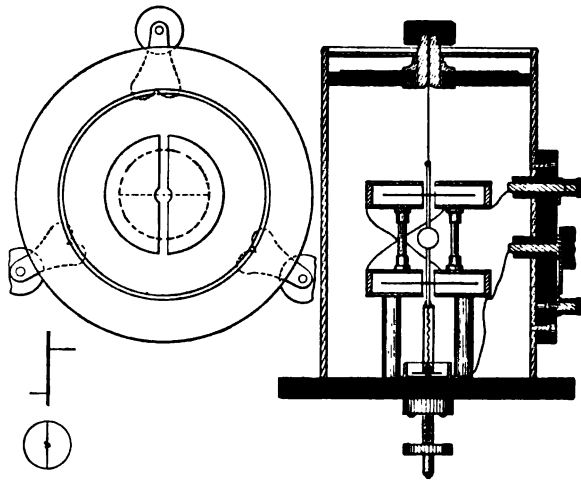

FIG. 1.

suspending wire is perfectly free, except at its point of support. Below the axis of the needle is connected by means of a spiral of platinum-silver wire to the brass cup containing paraffin oil as a damper. The mirror hangs midway between the two half circles forming the needle.

To set up and adjust to zero without leaving the suspending wire under torsion, the bottom of the spiral below is left free. The torsion head is then turned till the spot of light comes to the zero of the scale. Then the brass cap on the lower end of the spiral is attached by friction to the pin in the brass cup, and the cup is turned till the spot of light again returns to zero. Both the upper and lower wires are then free from torsion.

The scale, resting on the hard rubber at the top, is divided into 400 equal divisions, and the pointer is set to the zero of this scale after the preceding adjustment has been made. Connections with the mains are made by means of the rubber covered binding posts, as shown, and the key which is drawn in the charging position is made to discharge the quadrants or inductors by turning through 180° . The damper consists of a horizontal disk, supported by two wires from the axis of the needle, and having at its center a hole through which passes the pin holding the spiral.

When the instrument is charged, the system swings, twisting both the supporting wire and the steadying spiral at the bottom. This spiral has more torsion than the wire. The torsion head is

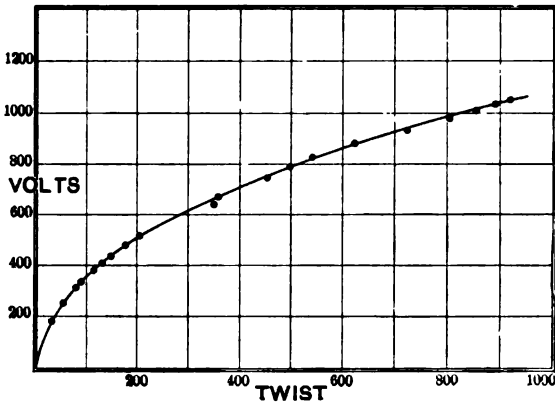

FIG. 2.

turned till the spot of light returns to zero, and the twist of the suspending wire is then read by the pointer on the scale. The spiral below has no influence on this reading since it is without torsion at the zero position, except in so far as the suspending wire shortens by the twist to which it is subjected. The instrument is practically dead-beat and its performance is in every way most satisfactory.

Fig. 2 shows the calibration curve. Since the instrument is used idiostatically, this curve should be a parabola. It departs from a parabola only very slightly. The constant increases a little on the upper readings, probably because of the shortening of the suspending wire as already explained.

The upper points of this curve were obtained by means of a

platinoid resistance of 4,000 ohms, wound non-inductively on three frames supported in a horizontal position, so that all portions of the wire remain at the same temperature. This wire is divided into four sections, and the resistance of each section is carefully measured. The smallest is a little less than $\frac{1}{4}$ of the entire amount. The whole is connected across the mains leading to the alternator, while conductors lead from the terminals of the smallest section to a Kelvin multi-cellular voltmeter. Successive readings were taken, while the voltage of the machine was made to vary by means of the resistance in the field of the exciter. For the lower points, which it was not practicable to reach by the alternator as above, recourse was had to a direct

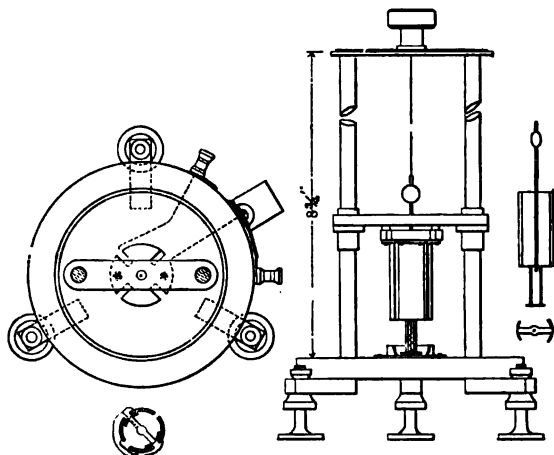

FIG. 3.

constant current dynamo and a Weston voltmeter with additional known resistance in series. This method was particularly satisfactory; and the regularity of the points obtained constitute a fine testimonial for the Weston instrument, in comparison with the irregular nutation of the points secured by means of the Kelvin multi-cellular. It will be seen that 1,000 volts were measured by a twist of the suspending wire of about two and a quarter turns. No appreciable set was observed.

This same instrument has been used with success to obtain the curve of primary E. M. F. of the alternator, no other apparatus being required except the usual contact maker on the end of the dynamo shaft. The readings may be taken very quickly and conveniently.

The second instrument is shown in section in Fig. 3, the case being omitted. The sectors are cylindrical and are supported on a hard rubber head, which in turn is rigidly attached to a strap of hard rubber supported on two brass columns. These carry the divided scale at the top. The hard rubber head is slotted, as shown at the left, to increase insulation between the cylindrical sectors. The needle consists of two cylindrical sectors shown at the right. The damper is made in the same way as in the first instrument. The entire suspended system in this case is aluminium except the spiral at the bottom, which consists of a very thin phosphor-bronze strip, made by rolling on a mandrel, annealing and finally re-tempering. The suspension is made by means of a quartz fibre. A much finer fibre than the one used would carry the system which weighs a little over one gramme.

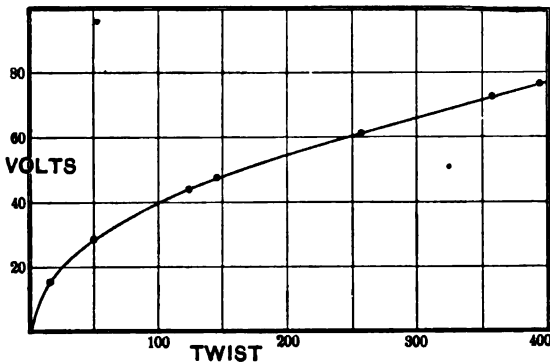

FIG. 4.

The adjustment to zero is made in the same manner as described in connection with the other instrument. This instrument is much more accessible for adjustments than the other, since the brass case can be removed without disturbing any of the parts. The cylindrical sectors are only an inch in diameter, the vertical adjustments are effected by sliding the supporting sleeves up or down on the posts, and the levelling screws are made so as to secure the instrument to the shelf on which it stands.

Fig. 4 is the calibration curve from about 16 to 76 volts. This was made with a temporary paper scale; and instead of lamp and concave mirror, which will be used finally as on the other instrument, a plain mirror and telescope were employed as a temporary expedient.

DISCUSSION.

THE CHAIRMAN :—Prof. Carhart's paper is before you for discussion. Are there any remarks?

PROF. A. G. WEBSTER, of Worcester, Mass.:—I would like to ask Prof. Carhart one or two questions. One is about insulation. He says the insulation is very good. I would like to know what is meant by the expression "very good;" and whether by using glass above and rubber below he can state why it is very good. I have been very much interested in surface leakage. I remember a paper in the *Transactions* of the *American Institute of Electrical Engineers* where a gentleman used a tension of 5,000 volts, and had no leakage whatever. I have been very anxious to find out how he did it. Prof. Carhart uses both substances, glass and rubber and I see he uses a very short distance of rubber, I suppose he finds it sufficient. This instrument is of course a very convenient one because it is a zero instrument. It occurs to me, and it may not be known to every one that there is a way that is a little quicker than bringing the reading back to zero. In cases where one does not wish to employ this method and bring the reading back to zero he can simply read once and swing and bring it back.

In regard to Prof. Carhart's remarks on Lord Kelvin's instrument it occurred to me to ask why he underrated his instrument with respect to Lord Kelvin's. I think his conclusions show his instrument to be as good as Lord Kelvin's.

With regard to the fibre, I would like to ask why he objects to the usual method in Thompson's electrometer. He puts in his spiral which his mechanic is skillful enough to make with very little torsion. It strikes me it was a dangerous thing to use this spiral when you are going to use quartz fibres. I fully believe that anybody who has used quartz fibres will use nothing else. I don't think any fibres will compare with quartz fibres if one knows how to make them.

THE CHAIRMAN :—I should like to ask one question in regard to the frequency of the calibration of the instrument, that is, supposing it is set up and used when necessary.

PROF. CARHART :—I think that I can answer the questions that have been asked, except perhaps the first one, satisfactorily. Now, in the first place, the lower parts must be supported substantially in order to hold the upper ones. My mechanic objects to using glass. Every physicist is very familiar with the fact that the insulation of hard rubber may not be so good after the instrument has been standing, but it is in a brass case that does not admit light. I have not made any relative test of the lead glass rod as compared to the rubber here, but I want to call attention to this fact that the insulation required in an instrument of this sort, which is constantly connected with a source of supply, is not the same as an instrument used in the ordinary way.

The electrometer leakage is of less importance, as you have the dynamo behind it all the time, even if the leakage is considerable. It seems that the leakage amounts to very little; it may change the calibration slightly but any leakage is supplied by the source from which the charge comes. I must also say, the instrument is a new one, and we have not had time to try it very much. And that answers Prof. Cross' question. We have not found out or have not had sufficient experience to tell how often it will need recalibrating.

Respecting the first swing and deflection, I have no doubt Prof. Webster has tried that. I don't think we shall use it any longer than until we can have something else to take its place. We have used it until we are utterly tired. I have never seen an electrometer in which the first swing is used that is satisfactory. You have the trouble of setting up the telescope and taking the reading, if you want to read the voltages by deflection. Again you have got to have a thousand volts, or you cannot have very large deflections, and then it will go off the scale. By making the torsion of the suspension wires smaller in my instrument you can turn the torsion head around as often as you please.

I think we can read very much more correctly and more conveniently than by taking the first swing. You can check it first in this way, and then you can take your time. You can read it as correctly as you please. As to sulphuric acid I should not like to be compelled to use it; it has always got to be watched. I tried a solution of zinc sulphate which was not good. The spiral, as you see, tends to hold the system from swinging. Suppose it is not supported centrally and the forces are unequal; the tendency will be to swing it over.

This spiral serves to hold the system, and prevents it from swinging over altogether, and you get rid of the sulphuric acid which is always annoying. With a high voltage that must be taken into account, the spiral also eliminates the inconstancy of the zero due to surface viscosity of the liquid used as a damper.

The CHAIRMAN:—The next paper is by Prof. A. G. Webster, on a Method of Governing an Electric Motor for Chronographic Purposes.

Prof. Webster then read the following paper:

ON A METHOD OF GOVERNING AN ELECTRIC MOTOR FOR CHRONOGRAPHIC PURPOSES.

BY DR. A. G. WEBSTER.
Clark University, Worcester, Mass.

The element of time is one of the important quantities upon which electrical measurements depend, and many of the most fundamental determinations, such as the absolute measurement of resistance, the determination of " ν ," the ratio of the two electrical units, measurement of capacities and of coefficients of inductions, involve a time-measurement as one of the principal data. The measurement suffers under the disadvantage that it cannot be preserved in a material standard, for while the meter and the kilogramme are defined by prototypes deposited at Breteuil, the second cannot be so deposited, nor directly copied. Nevertheless, the instruments for the measurement of time have reached such precision in our astronomical clocks and chronometers that we have little to complain of.

In electrical measurements, however, the element of time generally enters as an angular velocity, and the difficulty enters not with the clock, but in the preservation of the angular velocity constant enough for accurate measurement. Of course, a clock is but an instrument for preserving a constant angular velocity, and when the velocity is small, nothing else is to be desired. In our electrical measurements, however, our angular velocities are large, and clockwork is out of question. Clocks and chronographs, escapements and governors, moreover are at best delicate and expensive, so that no apology is required for an attempt to find something less so.

Next to a clock with pendulum or balance wheel, a tuning fork is a good time-keeper, and has been adopted, or what

amounts to the same thing, a reed has been used to govern a clock-train, in the Hipp chronoscope. The accuracy of the latter is, however, not all that could be desired. In electrical measurements the tuning fork has been of the greatest service and is the instrument upon which the time-measurement generally directly depends, the fork being used by the stroboscopic method to verify the constancy of the angular velocity.

The question of the maintenance of the constant velocity remains unanswered. It has often occurred to me to ask why the electric motor has not been applied in chronographic apparatus, and it seemed to me that this could often be done with material reduction of expense. In the course of some experiments last winter, when it was necessary to measure intervals of time of the order of a thousandth of a second with accuracy of one part in ten thousand if possible, so that an interval of a ten millionth of a second must be distinguishable, and high velocities were necessary, clockwork is out of the question, and I determined to try the motor, and to attempt to give it a positive governor.

The method adopted was of such simplicity that it must have occurred to all present, and was suggested by the method introduced by Lord Rayleigh, and elaborated at the German Reichsanstalt, for comparing a tuning fork with a clock, by means of Lacour's Phonic Wheel. The prevalence of the synchronous alternating current motor also suggested the practical means needed.

Upon the shaft of a small motor, carrying a drum and disk for registration, was directly attached the armature of a smaller motor arranged as an alternator, with separately excited field magnets. The current for the armature of the latter was made alternating by a commutator arrangement, composed of mercury cups and wires carried by the prongs of an electrically maintained tuning fork. The direct-current motor was now run up to synchronism, in hopes that the alternator would fall into step with the tuning-fork, and be automatically governed. As it is obviously out of the question to pass more than a very small current through a mercury break, the question of phase is equally important with that of synchronism, and it was at first found impossible to make the governor work at all. It was soon found that an alternating current was not necessary, but that an intermittent current would serve as well, so one of the reversed currents was left out, and the complicated commutator on the tuning-fork was reduced to a simple break.

In order to throw on the governing current at the right phase, a mirror was placed upon the end of a shaft, so that its normal was slightly inclined to the direction of the axis, and that a point of light would be seen as a continuous circle. A glow lamp reflected in a mirror, carried by the governing tuning-fork with an interposed slit, was looked at in this mirror, and instead of a continuous circle of light there was then seen a number of bright arcs, which diminished as the speed of the motor was brought up to synchronism. When the number of arcs is reduced to two, synchronism is attained, if the arc stands still; in practice, however, by means of a fluid rheostat in the circuit of the field magnets of the driving motor the speed is made gradually to vary, so that the arcs revolve slowly, and when a part of the revolution is reached that a few trials show to denote the proper phase, the governing current is thrown on, and the apparatus runs controlled, and the arcs of light stand perfectly still. In order to give instant notice of a failure of the governor, a telephone was placed across the terminals of the armature, which spoke up in stentorian tones of beats on the least divergence from synchronism, so that the observer would be recalled even from the farthest part of the next room. An ampere-meter also showed by the presence or absence of oscillations corresponding to the beats when the governor was acting properly. The motor which I used for driving was capable of giving out one-third of a horse power, and the number of revolutions was 32 per second. The tuning-fork was a large electro-magnetic fork by König, carrying a steel mirror, and a sliding weight.

In order to make sure whether the frequency of the tuning-fork was influenced by the controlling current, a large free fork was set up near by and was frequently bowed and compared with the electro-magnetic fork by means of Lissajou's figures. No difference was ever detected whether the governing current was on or off, although a difference of one part in twenty thousand could have been detected.

The accuracy of governing by this method is of course only limited by the constancy of the frequency of the electro-magnetic fork. In my experiments this generally amounts to about one part in ten or fifteen thousand, but I have no doubt that by the exercise of proper precautions it could be made much greater. This method dispenses with the services of one observer, and gives a marked increase in the accuracy of the determination of

angular velocity, one of the most troublesome measurements concerned in electrical measurements, so that I am left to hope that it may prove of practical utility in future determinations.

As there was no discussion on Prof. Webster's paper the Secretary, Lieut. Reber, then read the following paper, the author himself not being present :

IRON FOR TRANSFORMERS.

BY PROF. J. A. EWING, F. R. S., CAMBRIDGE, ENG.

In selecting iron for use in the core of a transformer, the first consideration is smallness of hysteresis losses; high permeability is comparatively a secondary desideratum. These two good qualities do not necessarily go together; the curve of the *B-H* cycle may have a relatively easy slope, and yet enclose a relatively small area. In actual tests the author has noticed that the order of merit in a set of samples is not always the same if permeability be made the criterion as it is if smallness of hysteresis losses be the criterion.

Notwithstanding the obvious and well recognized importance of small hysteresis losses in transformer iron, the metal that is actually used is often of a very poor quality in this respect. The author has been much struck by this in the course of a recent experimental inquiry, in which ten or a dozen specimens of iron were examined, most of which were supplied either as transformer iron or as specially pure metal prepared for the purpose of the experiment. In only one case were the hysteresis losses as low as they had been found to be in some wire which the author tested in 1881, in the laboratory in the University of Tokyo, and in most cases the losses were much greater. In the Japanese tests which were made before the days of alternate current engineering, when the word hysteresis was to be found nowhere but in the Greek dictionary, wires were taken at random from the stock which the laboratory chanced to furnish. Two of them were about equally good; one of them was probably a piece of native iron, and the other was wire sent by an American manufacturer to an exhibition in Japan. Since then many observers

have made tests, and, obtaining decidedly inferior results, have not unnaturally been led to express themselves in terms of politely veiled skepticism about the Japanese figures. It is, therefore, interesting to notice that one sample among those most recently tested by the author has given results which are substantially on a par with those given by the Japanese wires. Under strong magnetization it is not quite so good, but when the magnetization is moderate or weak there is practically no difference. The sample in question was thin sheet iron, used by a well known English firm in the building of their transformers. But the corroboration of the old figures, interesting as it is, only serves to emphasize the contrast between the good and the bad. Other iron, also used by eminent makers of transformers, and also, like the last, carefully annealed before testing, turned out so markedly inferior that the author does not care to indicate the sources of his specimens by any more particular description. And the case was even worse with some iron supplied as specially soft and pure.

The following figures may be taken as representative. They give the value of $\int H dI$, or the hysteresis loss incurred in a complete cycle of magnetic reversal, for various values of the magnetic induction B which is reversed. Column 1 states the results of one of the old Japanese tests; column 2 refers to the good sheet iron mentioned above, and column 3 refers to another specimen of transformer metal, where it will be seen the losses are about half as great again as in the other. Column 4, where the losses are much greater still, relates to a test of some wire which was furnished as a specimen of particularly fine Swedish charcoal iron.

TABLE OF HYSTERESIS LOSSES.

B	Values of $\int H dI$.			
	1	2	3	4
2000	400	420	600	1100
3000	780	800	1150	2150
4000	1200	1260	1780	3300
5000	1680	1770	2640	4700
6000	2200	2370	3300	6200
7000	2800	3150	4300	7800
8000	3430	3940	5300	9500
9000	4160	4800	6380	11400
10000	4920	5730	7520	13400
11000	5800	6600	8750	15600
12000	6700	8000	10070	—

The figures given by Mr. C. P. Steinmetz in his paper on the Law of Hysteresis (*Am. Inst. Elect. Engrs. 1892*) give additional evidence of the wide variation which this quality is liable to exhibit in different specimens of nominally soft iron.

Chemical analysis is apparently an imperfect guide in the estimation of magnetic quality, and to some extent this is intelligible enough. Puddled iron, for instance, liberally streaked with slag, may seem on analysis less pure than specimens of ingot metal which have much higher hysteresis losses. It is not improbable that much of the inferiority of which most modern sheet and wire iron undoubtedly shows in this respect may be due to traces of foreign elements which have become chemically incorporated with the metal through the use of methods of manufacture which are ill adapted to yield a good product from the magnetic point of view, however successful they are in producing a mechanically good iron. Manganese, so essential to the strength and toughness of ingot iron, is well known to be deleterious magnetically. The makers of transformers complain that they are unable to get metal of the quality they want except by a kind of happy accident, that the conditions which bring about a good result are so imperfectly understood that they cannot be reproduced with any certainty. Much of the same thing was true in the early days of mild steel, and incessant testing contributed to put matters on a surer footing. Magnetic testing is now easy for makers as well as users of iron, and it may be expected that specifications of magnetic quality, and particularly of hysteresis losses, will soon become commoner than they are. From being a mere laboratory affair, interesting only to the curious physicist, the subject has in a few years advanced to the front rank of practical questions, and affects wide commercial interests.

The form and general design of transformers has received all possible attention at the hands of engineers, but of the material which mainly determines their efficiency we apparently know very little. It is scarcely satisfactory to reflect that good makers are turning out machines which waste twice as much power as they need waste.

The author brings these remarks before the Congress in the hope that some suggestions may be made which will lead to a better understanding, as between electricians and iron-makers, of the conditions which govern the production of magnetically soft iron.

July, 1893.

It was voted that a recess be taken till 12 o'clock. On re-assembling the Chairman said :

It is now past the hour at which we were to re-assemble, and Prof. Jamieson will read his paper, entitled "London Electrical Engineering Laboratories."

PROF. JAMIESON :—The title of this paper as on the programme is not exactly correct. I was astonished to find my name put down for a paper on "London Electrical Engineering Laboratories" when I arrived at Chicago. I simply hinted in a letter that I had a few notes on such a subject, and my name was put down, and I had to write this paper in the last two evenings in my hotel.

Prof. Andrew Jamieson then read the following paper :

LONDON ELECTRICAL ENGINEERING LABORATORIES.

BY PROF. ANDREW JAMIESON, M. INST. C. E., F. R. S. E., ETC.
Glasgow Technical College, Scotland.

I. ADVANTAGES OF COLLEGE LABORATORIES AND WORKSHOPS.

The teaching of engineering in its various sub-divisions (civil, mechanical, electrical, chemical and mining engineering) has been greatly improved of late by the addition of laboratory and workshop practice to the class room lectures and demonstrations. This is more especially evident with electrical engineering, for in this branch not only the most delicate apparatus, such as electrometers and galvanometers, but also all kinds of commercial instruments for measuring strong currents and high pressures may be so fitted in a college laboratory as to enable students to obtain a thorough knowledge of their construction and action, together with the results derivable therefrom. In addition to instruction given by the aid of such physical appliances, it is possible to teach students to turn, file, fit and solder metals, how to joint wires and cables for telegraph, telephone and electric light circuits, as well as how to test and manipulate the various instruments connected therewith. Further, when space and funds are available, steam engines and boilers, gas and oil engines, continuous and alternate current dynamos, accumulators, lamps, transformers and motors may be readily accommodated and so placed at the disposal of students that they can sketch, manipulate, investigate and report upon them, with a freedom such as no engineering works would tolerate or could afford to give to their apprentices. In a college laboratory it is also possible to give students a more thorough insight into the changes which electrical engineering appliances have undergone during the rise and

progress of the science, than in a commercial workshop, as well as into the modifications desirable under different conditions and circumstances. For example, the college engine may be worked and tested as a simple, compound or triple expansion engine, with or without condensation, with jet or surface condensers, with or without steam jackets, and under all practicable grades of expansion and velocities, etc.; the continuous current dynamos may be run separately excited, or as series shunt, or compound machines, and the different characteristic curves plotted. The armatures may be supplied with a search coil and with different anti-sparking devices. Alternate current dynamos, motors and transformers may have their fields, speeds, phases and frequencies altered to any desired extent. Primary and secondary cells may be joined in series or in parallel and treated kindly or run to death, all for the instruction of the student and the advancement of knowledge. Whereas in a commercial workshop the apprentice may only have one or two types brought under his notice, and in a very few places will he be permitted to experiment with or alter the original design, even to the smallest detail.

Of course a student must not depend entirely upon the laboratory and class room for his complete training. *Otherwise he will lack the necessary knowledge of how to use materials, tools and men to the best pecuniary advantage.* He should endeavor to combine, supplement or prepare for his college education by an apprenticeship in a good mechanical or electrical engineering workshop. In any case this apprenticeship need not be so long or so arduous as it would otherwise be without a college training; more especially if his teachers are men who have themselves undergone a complete course of workshop instruction, and who are not only conversant with the latest developments of mechanical and electrical engineering, but who are in touch with installations and works so that they can take their students to the same, and thereby instruct them in their everyday working details.

There are many young men upon whom a complete *day-class* college education would be thrown away. We must have "hewers of wood and drawers of water." These must of necessity go through the regular mill of five or six years continuous apprenticeship, picking up as best they can the various workshop details and the requisite skill of hand and eye to make a good workman. The more intelligent and ambitious will no doubt

avail themselves of evening science classes, and may thus, in fact they often do, out-strip their more fortunate competitors. If a lad has the pecuniary means and if his heart is thoroughly bent upon rising to the higher positions of their trade or profession, and if he is at the same time endowed with a fair talent for mathematics and drawing, he will undoubtedly find that a combined day-class college and workshop training pays best in the long run. Employers of labor, more especially in the United States of America, are now only too glad to avail themselves of cultured intelligence, *provided that it is combined with a willingness to do at once exactly as told, and the keeping of regular hours.* If such qualities are wanting in a college trained youth, then the employer will naturally push on and give preference to the less educated but more thoroughly broken in workshop apprentice to the chagrin and disappointment of the former.

II.—SHOULD A COLLEGE TRAINING PRECEDE, BE COMBINED WITH OR FOLLOW AN APPRENTICESHIP ?

This is the vexed question which has been receiving unremitting attention in Great Britain ever since the introduction of technical schools and colleges. Personally I have given it a great deal of thought and care, and to this day I treat each case as it comes before me, upon its merits. In the discussion which follows the reading of this paper, I hope that we shall have the views of the commercial engineers and the professors of this country, a country which has exhibited more go-aheadness than any other in certain lines of engineering. We still have in the old country many engineers who sneer at a college education, and who place little or no value on diplomas and degrees. They say that no one can become a thoroughly useful practical engineer unless he serves a complete apprenticeship in their shops, of at least *five* continuous years. Some of them even object to their apprentices attending evening classes, for fear that they will not start work at 6 A. M. They say that they went through the mill and rose to their present position without any such lectures and laboratory practice. They boast that they can still take off their coats and show their workmen how to set about a job. They relate how they have gained their experience, and how they know whether a machine will turn out a success or not. They entirely ignore the fact that a very great deal of their slowly gained experience may be “boiled down” and given in a concise,

palatable form to the rising generation. Moreover, such men persist in appointing as foremen and managers great burly "rule of thumb" fellows, who can push on the work and who are not slow at using the big, big D, in order to stimulate and draw forth the elbow-grease of their workmen. Now we must not ignore or despise the opinions of such men, for they are in earnest, and they can (owing to their wealth, influence and numbers) seriously hamper the prosperity of a technical college. We should rather endeavor to induce them to try some of our more intelligent scholars. From thirteen years' experience I have found that if you can only plant a bright, intelligent, well educated youth with an engineer of the aforesaid description, he will take his pennyworth out of him, and although he may be slow to acknowledge the error of his ways, he will be glad to see you back again with a similar application. I believe that in a short time employers of labor and professors will see, eye to eye, in this important question. My own opinion is that in the case of a youth whose parents are fairly well off, the lad should first receive a sound English education. If he is of a fidgetty or conceited disposition, prone to change, and to fiddling away his time in making toy models of steam engines or dynamos, he should begin with the works, so as to tame and lick him into shape. If, on the other hand, he is of a steady, thoughtful, observant temperament, possessing good mathematical abilities, he should commence with the college. The best plan of all is, however, to combine the two methods. In this respect we are perhaps more fortunate in Scotland than in almost any other part of the world, for our session is concentrated into winter months. We have thus the opportunity of testing the character of our students during the first session, and of advising them, their parents and their probable employers whether they should come back to us for the second and third year courses, or finish their apprenticeship right away before returning to the college. Such an arrangement works admirably, for should the student be of the right sort, he spends six months at the college and five months at the works each year for three years, finishing off with two years at the works, and at the higher evening classes, which are specially suited to the requirements of senior apprentices and draftsmen. To this happy combination of theory and practice, as well as to the porridge and milk of Scotland, I attribute the success of our students. Since starting from the Clyde, I have met and heard

of many of them occupying responsible positions on this continent, and we shall be glad to furnish as many more as you may see fit to employ. Fortunately for us in Scotland, premiums are the exception rather than the rule, as in England. A lad is taken on for what he is worth, without any binding indenture. Premium pupils are considered a perfect nuisance. A small wage is paid to every apprentice, and he is retained or expelled at a week's notice. If he is earnest, diligent and a good time-keeper it is to the employer's interest to retain him. If he can draw and calculate accurately, it is to his interest to promote him to the drawing office. In fact, several of our best Clyde firms, notably the Messrs. Drury of Dunbarton, and Napiers of Glasgow, etc., hold a special investigation for admission into their drawing offices, which investigation takes into account the previous work and conduct of the pupil, and hence our college paying students stand a better chance of such promotion than ordinary lads who have not had such advantages.

III. LONDON ELECTRICAL ENGINEERING LABORATORIES.

It was my good fortune to spend about a fortnight this summer visiting the London Electrical Engineering Laboratories, with a view to improving my own one in Glasgow. In every instance I met with the greatest courtesy and kindness, which, I may here add, has also been notably the case when visiting the various works in this country. We form, I believe, one common engineering brotherhood, and whenever the request for information does not directly clash with our own individual interests, we are, as engineers and electricians, only too pleased to show the right hand of fellowship to a brother worker, and to extend to him any help that lies in our power.

Seeing that a combined college and workshop training need not occupy more time than a five years' apprenticeship of the old type, and considering the fact that employers of laborers are of necessity being gradually forced by competitive circumstances to employ technically educated assistance, it is not to be wondered at that in the metropolis (which is still the great centre of our electrical industries), there should have been started many electrical engineering laboratories and science classes. These laboratories are to be found in connection with institutions and colleges where the other collateral subjects forming a complete curriculum are also taught, so that a youth may receive as com-

plete a scientific training as possible. Some of them are well endowed, and are therefore able to charge nominal fees, whilst others, having no endowments whatever, are under the necessity of charging what we in Scotland would deem very high rates for instruction. In all of them, however, there seems to be no lack of pupils. Each laboratory has a distinct character of its own, appealing to a certain class of students. Undoubtedly the best equipped electrical engineering laboratory in London, or in Great Britain, for that matter, is that conducted by Prof. Ayrton, at the Central Institution of the City and Guilds of London for the advancement of technical education. The students who elect to go in for the full three years' course receive the same theoretical instruction during their first and second session as those attending the mechanical engineering laboratory under Prof. Unwin. In their third year they devote their attention wholly to electricity and its applications. In the basement of the building there is a boiler, engine and dynamo room, with a power testing room adjoining the same. These rooms are fitted with all the most recent instruments of precision for measuring the consumption of fuel and steam, and the efficiencies of the engines, dynamos and motors. In addition to this testing room there are three large electrical engineering research laboratories, together with special departments for investigating problems on light, heat, sound and magnetism. Two workshops, with skilled mechanics, furnish the more immediate wants of the various laboratories, and also serve as a means for training the students in jointing, etc.

Finally, there is a very convenient lecture room, with ante-room for apparatus, and a professors' room. During the third session students are encouraged to carry out original research work. The result of this graduated system of instruction may be gauged by several papers of the highest merit brought before the learned societies by the professor and his more advanced pupils. I believe that to-morrow morning in this place you will have one of these papers submitted to you by Prof. Ayrton, containing a most elaborate series of observations on the "Variation of the Potential Difference of the Electric Arc with Current, Size of Carbons and Distances Apart," that will better exemplify than any words of mine the manner in which he gets his students to investigate practical problems of the highest interest and utility. These students come from every part of the globe, even from

the United States. I have not the slightest hesitation in stating that any student who has passed through a technical school or university college course might spend a session most profitably in finishing at this extensive and well organized laboratory.

Next in importance, and appealing to the same class of students, viz., those who are desirous of taking a prominent position in the electrical engineering world, is that of the "Sir William Siemens' Laboratory," presented to King's College, London, by Lady Siemens, in memory of her late husband. It is presided over by Prof. Dr. John Hopkinson, who has done as much as any one for the higher advancement of electrical engineering. It is divided into two portions, viz., the boiler, engine and dynamo testing room, situated in a vault next to the Thames' embankment, and the research laboratory at the uppermost Strand end of the College. Here there is only room for comparatively few students, but the apparatus is so good and new that any one will obtain an excellent training, more especially in that department of the science to which Dr. Hopkinson has devoted special attention, viz., the magnetic circuit of dynamos and transformers.

In the end of May and the beginning of June of this year the several British engineering journals gave very complete illustrated descriptions of the new mechanical and electrical engineering laboratories which have just been erected and are now being equipped in University College, London, at a total cost of £20,000. The first engineering laboratory of any consequence in Great Britain was started by Prof. Kennedy in this College in 1878. It gave an impetus to all similar institutions, and seeing the progress has been so very rapid in this direction, it speaks well for the governors of their college that they have not rested content with what they had, but boldly appealed to the friends of the college and to the public for funds. They have specified for a set of laboratories which they hope will be second to none in the country. Most certainly, if Prof. Fleming can have his own way, he will desire to instruct his students both by lectures and laboratory practice in all the latest and best ideas on alternate current generation, transmission and transformation, which subject he has made a special study, and written as well as lectured much to the great advantage of the electrical world at large. We now come to Finsbury Technical College, presided over by Prof. Dr. S. P. Thompson. He takes immediate charge of the electrical department, which has five distinct laboratories. One of

these is of special interest, as nowhere else did I find anything like it of the kind in conception or extent. It is devoted entirely to the electro-deposition and electro-plating of metals, which is a very large and remunerative business in London. Here are to be found vats for the deposition of gold, silver, nickel, copper, etc., with all the necessary appliances for producing the molds and for finishing off the deposited metals, as well as for testing the quality of the solutions. Some very pretty and original work has been done in this laboratory. I was glad to see that Prof. Thompson had secured the service of a thoroughly experienced electro-plater to take charge of this department under him. In fact, what struck me most forcibly in connection with all the laboratories in London was this, that the assistants were men of experience, well paid for their services, and not merely green pupil teachers, depending upon a mere pittance and a certificate from their professor as a recompense for their work. Of course such highly paid, skilled assistance can only be obtained in well endowed institutions, such as under the City and Guilds of London, of which Finsbury College is one. This College is divided into two distinct sections. The day classes for those of fourteen years and upwards, who pass a stiff preliminary examination, and are prepared to devote one, two or three years to systematic technical education. The evening classes are for those who are engaged in industrial or commercial occupations during the daytime, and who wish to improve their knowledge in the science or art of their calling. The same laboratories are used for both the day and for the evening students, which is a pity, as it is found to be a great tax on the rooms, on the apparatus and the teachers. This college affords a preliminary training for the higher classes of the Central Institution on Exhibition Road, South Kensington. It, however, goes sufficiently far for most youths, especially in the mathematical treatment of the subject. The boilers and engines (both steam and gas), as well as the dynamos, are very complete from an educational point of view, but the opportunities for experimental research are of necessity limited by the age of the pupils and the difficulty of having to accomodate such an overflowing number of applicants into both the day and the evening classes. We must not forget to mention the Royal College of Science, South Kensington, or what is generally known as the Science and Art Department. Although the laboratory there is more of the nature of the Kelvin Laboratory

at our Glasgow University, or the Andersonian Laboratory at our Technical College under Prof. Blyth; being devoted more to pure than to applied electricity, yet some very original, interesting and instructive researches have been carried out in it by Prof. Boys, which have been of great use to electrical engineers.

The apparatus here is good of its kind, but the laboratory is by far too cramped. Rumor, however, has it that the British Government have secured an extensive site opposite the Imperial Institute, where they intend to erect physical and electrical laboratories worthy of the high position which they wish their college to attain, as the pattern of all such laboratories, under their supervision, throughout the length and breadth of the United Kingdom and Ireland. Their space and money have been largely spent hitherto in providing rooms, cases and specimens of art, to the exclusion of physical science and its application: but if they are to keep abreast of the times they must now devote a considerable sum to the latter cause. You may wander for hours through the unique collection of pottery, carvings, etc., etc., and scarcely meet a person who is studying them with effect; whereas their science class rooms are as full as they can hold, but without the requisite laboratory accommodations and appliances to give proper effect to the instructions of the learned professors. At the Faraday House, Charing Cross Road, there is an institution of a different kind from any we have mentioned. It is called "The Electrical Standardizing, Testing and Training Institution." The objects of this institution are very tersely set forth in their prospectus (which I now hold in my hand), and which may be obtained from the principal, Mr. Hugh Erat Harrison. The fees are 105 pounds per annum. It is therefore suited to the sons of rich men, who may have a bent for electrical pursuits, or who may desire to succeed to a partnership after they have gained some electrical knowledge. It is backed by several engineering companies and men of position in the electrical world. The apparatus and the instruction appear to be sound and good as far as they go, and the pupils have the additional advantage of assisting those engaged in the standardizing laboratory, or of being specially appointed to work when their theoretical training has reached a certain approved stage. Besides the standardizing laboratory there are private rooms set apart for inventors who are not able to procure continuous and alternate currents at home, and who desire to perfect their apparatus before submitting them to the scientific or commercial world.

The School of Electrical Engineering and Sub-Marine Telegraphy, situated at Hanover Square, London, has now been closed, and I understand that the kind of instruction which used to be given there is now being continued by Mr. Tunzelman at Pennyween Road, Earl's Court. This school supplied in its day many probationers to the great sub-marine telegraph companies, and latterly to electric lighting firms. The electric light training was similar to that now given at Faraday House, but they had in addition a complete outfit of artificial cable, syphon recorders and galvanometers. Time will not permit of my explaining the work carried on at the People's Palace under Messrs. Slingo & Brooker, whose book on Electrical Engineering is no doubt well known to many of you. Neither have I time to mention what is done at the Royal Indian College, Cooper's Hill, the Crystal Palace Company's School of Practical Engineering, the London College of Electrical Engineering, or the Polytechnic, Regent street. I must, therefore, refer those who are interested in this subject to a recent publication, termed "Electrical Engineering as a Profession, and how to enter it," by Mr. A. D. Southam, issued by Messrs. Whittaker & Company, Paternoster Square, London, and 112 Fourth avenue, New York, where they will find an account of all the more prominent schools and colleges in Great Britain and America that give instruction in electrical engineering, as well as the names and terms of admission and apprenticeship of English firms. I would also refer you to Prof. Ayrton's inaugural address upon entering the presidentship of the Institution of Electrical Engineers, last session, for his views on this subject. I have just learned that Prof. Thurston, of America, gave a lecture on a similar subject before the Mechanical Engineering Congress held here a few weeks ago. I am sorry that I have not had an opportunity of seeing his paper before writing this one. Had time permitted I should have liked to have said something about the examination question, and the value of diplomas and degrees. My own idea is that the examination should be so arranged and pitched as to prevent the possibility of cramming, and to exclude those students who merely wish to fiddle away their own and their master's time. As an instance of what I mean, I will conclude with stating one of the questions that I gave at the final examination in April last for the diploma in electrical engineering at the Glasgow and West of Scotland Technical College. "Go to

the Faraday Works, Govan, and there make a complete set of free hand sketches of a ship lighting plant. From your sketches make a set of finished drawings. Take indicated horse power cards, brake horse power and electrical horse power tests, at the normal speed and power of the engine and dynamos. Find the mechanical efficiency of the engine, the electrical and commercial efficiency of the dynamo, and write a concise report upon the suitability of the plant for the work it will have to do. You can take five days to this question. You are permitted to consult any book, but you must state the name of the book and the page whereon you got the information." I may add that another question there was also allotted five days, as well as three days of six hours each to written examinations in the theory of practice of electrical engineering, before the students had completed their task. In some of these other examinations books of reference were also permitted. The whole set of examinations being conducted to ascertain if the young men could apply the knowledge they had gained during their previous years of training in such a rational business-like manner as would prove whether they could be recommended for admission into works.

DISCUSSION.

THE CHAIRMAN :—I presume the subject of electrical engineering education is one to which the programme committee well might have assigned at least a whole day, but it probably was not feasible. The subject of Prof. Jamieson's paper is now open for discussion.

PROF. A. C. LONGDEN :—I was very much pleased with the way in which Prof. Jamieson suggested the combination of apprenticeship with a college education so far as Scotland is concerned, but in America the conditions are somewhat different, at least in two respects. In the first place the college student is in school nine months or more of the year instead of six ; now when he takes his vacation there is little time left to work in apprenticeship in the summer. Then in the second place an apprenticeship in this country does not mean what it does in the older countries. It does not mean an education in any particular branch or trade. It means education with regard to the use of one machine. An employer will put a young man at work at a machine, and the longer he stays at that machine and the better he knows how to use it the less likely he is to get to work at any other machine. So it seems to me in this country that instead of a combination of an apprenticeship and a college education, that it is almost necessary to have the apprenticeship as a part of the college education, and give the necessary time to the work,

within the technical schools at any rate, such schools as Cornell University and the Massachusetts Institute of Technology do give such an amount of work as will enable the student when he goes out to go into practical work without very much of an apprenticeship.

DR. LUDWIG K. BÖHM, of New York :—I should like to make a few remarks outside of what I might call geographical boundary. Prof. Jamieson in his very able paper put forward three great points. Shall the college education go alone or shall the college education go with an apprenticeship, or shall the apprenticeship go first. Now with reference to this I would like to say that men are trained for various works in life, and consequently a course to be followed has to be selected for the special intended purpose. In the olden times in the German University the student simply learned such things in natural science as the professor chose, and others were passed. There was no regular system in it; but in modern times the thing has changed completely. Colleges are conducted in very systematical ways, commencing with the easiest and ending with the most difficult parts of every branch of science. With reference to the various schools of England and this country I might say as far as my experience goes in England as well as on the continent, the student has to be considered as well as the college. The boys on the other side generally enter college better prepared than on this side of the Atlantic, as far as my experience goes. In most of the higher schools they are demanding a great deal more general education in all the branches of the sciences so as to enable the student to digest what the professor is teaching. I should like to say a few words about this apprenticeship. As a rule, the apprenticeship prepares the young man, as Prof. Longden said, for working a special machine. The college trains the boy so that he may be able to work his way in to any position that may be offered in a special branch of science, but yet as far as I am concerned I look at it in this way, that a man who trains himself in electrical engineering has to be considered a scientifically educated man. He has to first learn the rudiments of the sciences at the colleges and then enter with his knowledge into the practice. The electrical engineer should be a scientifically educated man, and consequently requires as much as possible a thorough theoretical training in a school before he enters practice.

THE CHAIRMAN :—I will call for further remarks, but you will excuse me if I say the remarks should be made as brief as possible, as our time is short.

MR. J. O. REED, of Ann Arbor :—I would like to ask Prof. Jamieson as to the amount of mathematical training required; also as to whether the students are given any instruction in the modern languages and the ability to use French and German.

In America, in the Michigan University, we lay great stress upon that. We also think that a successful electrician should be a man who can handle mathematics well.

THE CHAIRMAN :—Any further remarks ?

MR. HAYES :—I think we should all be very glad to hear from Prof. Cross, as he has charge of one of the largest educational establishments of electrical engineering science in the United States.

THE CHAIRMAN :—Are there any further remarks ?

I think it quite undesirable that the Chair, when the time is so short, should dwell on even so important a subject as the question of instruction in electricity. I think most of the Americans present are familiar with the institution with which I am connected, which is not remarkably different from other technological schools in its plan. Knowledge of the instruction given in electrical engineering in this country can be most readily attained by considering the exhibits in the liberal arts building. They give a far better idea of the work done in our school than I can do here. There are three things which I will venture to say. In the first place I am very glad to state that it was my experience from the beginning, that the feeling of the employers in this country is not that which Prof. Jamieson has indicated as still to be found abroad. I have never met an engineer who had attained to success who did not rejoice with all his heart in the establishment of technical schools and the introduction of such courses into the colleges, so that the young men might have the advantages which he had lacked. We have had no more earnest helpers in our technical schools than these eminent engineers who have always been ready to take hold and help us not only with their advice, but have come directly into the lecture room and given talks. I think we lack in this country schools for electrical artisans as distinguished from electrical engineers. I do not know of any school which trains electrical artisans. We have schools of training for other trades, but not for that. And last I want to do here what I have done in another place in print, to acknowledge most heartily the help which I personally received, and which the Institute received from the works and suggestions of Prof. Ayrton. It was owing more to the papers of Prof. Ayrton than to any other one thing that I was led to suggest the establishment of our course of electrical engineering, the first opened in this country. I do not doubt that my colleagues will have the same feeling in regard to Prof. Ayrton which I have myself.

PROF. JAMIESON :—The last two speeches require some explanation. Mr. Reed asks what attention we require for our department of mathematics. We require mathematics and natural philosophy in engineering. We insist upon a stiff examination of French and German; there is no exception to that. And then there is logic and political economy. I am very glad, indeed, to find that my friend here, Prof. Cross, is free from that bugbear, the old conservative engineer. We have had to fight them for a number of years. I can assure you, you have no idea how much trouble these worthy old fire eaters have given us. It is only now when our students are growing up and enter-

ing our works and getting to be managers that we are getting to be patted on the back as teachers in colleges and universities. I quite agree with Prof. Cross, that in this country we should have special laboratories and schools for electrical artisans, and as the gentleman has said, an electrician should be an educated gentleman.

I am very glad to have had this opportunity of presenting this paper before you, and I shall return to Scotland very much improved by what I have seen, and very much impressed with the courtesy I have received both here and in New York.

THE CHAIRMAN:—We will now listen to the reading of the paper written by Dr. Frederick Bedell, assisted by A. W. Berresford, W. M. Craft and B. G. Gherardi, Jr., entitled, "Transformer Diagrams Experimentally Determined."

Dr. Bedell then read the following paper:

TRANSFORMER DIAGRAMS EXPERIMENTALLY DETERMINED.

BY DR. FREDERICK BEDELL,

ASSISTED BY A. W. BERRESFORD, W. M. CRAFT AND B. G. GHERARDI. JR.

Of the various experimental methods used in alternating current work, those are most valuable which ascertain the phase relations of the different currents and electromotive forces, inasmuch as without a knowledge of these relations a full understanding of the phenomena is not possible. Phase relations may be shown by plotting curves representing instantaneous values; or they may be shown by polar diagrams if the currents are harmonic or are assumed to be the equivalent of certain harmonic currents. The representation of the results of alternating current experiments by polar diagrams has an advantage in the fact that such may also be constructed according to theoretical considerations, thus enabling us to compare experiments with theory. The work which is described in the following paper was undertaken with the object of experimentally determining polar transformer diagrams for comparison with similar theoretical diagrams, with particular reference to the effects caused by the variation of the constants of the transformer, as described in a current series of articles entitled the "Theory of the Transformer." *

Experiments were made upon a small transformer, with an output of about 500 watts, constructed and used by Dr. Crehore and the writer for experimental work. This transformer was particularly adapted for the present investigation since it was provided with means for varying the reluctance of the magnetic

* Bedell and Crehore, *Electrical World*, Vol. XXI., No. 12, March, 1893, et seq.

circuit and thereby the coefficients of self and mutual induction. This variation was produced by the moving of an iron tongue in and out of a gap in the metallic circuit. Fig. 1 shows in diagram the magnetic circuit of the transformer and the arrangement of the movable tongue. A laminated iron tongue, Δ , is arranged so that it may be rotated about an axis occupying the central line of the circular gap which it fills. In the position in which the

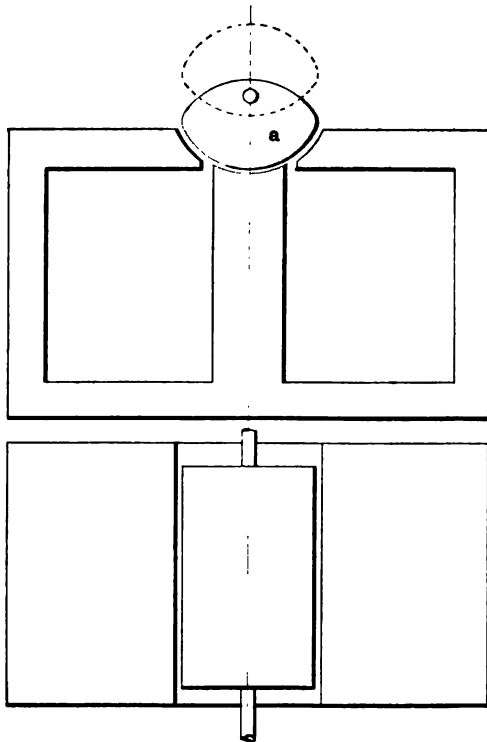

FIG. 1.—Arrangement of Transformer. (Half Size.)

tongue is represented in the figure, the magnetic circuit is as nearly complete as it can be made. When the tongue is moved through 180° to the dotted position in the figure, the magnetic circuit is most imperfect and the reluctance is highest. The tongue may be moved by an arm and secured in any desired position, and the position is indicated by a pointer moving over a graduated scale.

The essential dimensions of the transformer are as follows:

Length of core (perpendicular to lamination).....	2½ inches.
Width of each plate.....	5 "
Length of each plate.....	3 "
No. turns large coil.....	128
No. turns small coil.....	90
Size of wire in both coils.....	No. 10 B. & S.
Resistance of large coil.....	2272 ohms.
Resistance of small coil.....	160 ohms.
Cross section magnetic circuit.....	12 sq. cm.

Either coil may be used as primary or secondary.

Changing the position of the tongue alters the reluctance of the magnetic circuit and alters the coefficients of self and mutual induction accordingly; these coefficients increase as the reluctance decreases, and have the highest values when the tongue is all in.

DETERMINATION OF THE COEFFICIENTS OF INDUCTION.

Preliminary to the experiments proper upon the transformer, the values of the coefficients of self and mutual induction of the coils were determined for the different positions of the tongue.

For alternating current work, when a reliable voltmeter and ammeter are at hand, the coefficient of self-induction may be readily determined from a determination of the impedance. Measuring the current which flows through a coil when a certain measured electromotive force is impressed, we obtain—

$$\text{Impedance} = \sqrt{R^2 + L^2 \omega^2} = \frac{E}{I},$$

where R = ohmic resistance,
 L = coefficient of self-induction,
 E = electromotive force,
 I = current,
 $\omega = 2\pi \times$ frequency.

When the ohmic resistance is small as compared with the effect of self-induction, as is usually the case in transformer coils, the value of L becomes

$$L = \frac{E}{I \omega}.$$

The coefficient of mutual induction was found by passing an alternating current through one coil and measuring the electromotive force induced in the other. The primary current was

measured by a Thomson balance, and the secondary electromotive force by a Cardew voltmeter connected across the open circuited secondary. The secondary electromotive force is

$$E_2 = M \omega I_1,$$

whence the coefficient of mutual induction is

$$M = \frac{E_2}{\omega I_1}.$$

As a matter of convenience, the values of the coefficients of self and mutual induction were obtained by simultaneous measurement. The values of these coefficients for six different positions of the tongue are given in the accompanying table.

TABLE OF CONSTANTS.

No.	Arm.	L_s .	L_L .	M . Ob- served.	M . Com- puted.	$\omega = 863.$			$\omega = 566.$			$\frac{L_L}{L_s}$
						$L_s \omega$.	$L_L \omega$.	$M \omega$.	$L_s \omega$.	$L_L \omega$.	$M \omega$.	
1	0	.00908	.01743	.0122	.0126	7.83	15.04	10.53	5.15	9.87	6.91	1.92
2	70	.00988	.01924	.01258	.0138	8.52	16.6	11.08	5.58	10.78	7.26	1.95
3	90	.01111	.02199	.01501	.0156	9.60	18.95	12.95	6.30	12.45	8.50	1.98
4	120	.01247	.02525	.01774	.0179	10.73	21.8	15.30	7.05	14.30	10.03	2.02
5	150	.01427	.02918	.0209	.0204	12.31	25.32	18.05	8.09	16.65	11.83	2.05
6	180	.01578	.03310	.02338	.0229	13.6	28.6	20.17	8.93	18.73	13.24	2.10

The position of the tongue is indicated in degrees by the reading of the pointer over the graduated scale, the tongue being all out at 0° and all in at 180°. The two coils of the transformer, either of which may be primary or secondary, are distinguished as the "large" and the "small" coil, and by the subscript letters L_L and L_s , respectively.

In obtaining the coefficients of self and mutual induction for different positions of the tongue, observations were made for different values of the current. The values obtained for the coefficients decreased as larger currents were used, this variation extending through a range of five or six per cent. Mean values were taken corresponding to the currents used during the experiments and the coefficients were considered constant.

The coefficients increase steadily as the arm is moved in from 0° to 180°, but not by equal increments. The positions 0°, 70°, 90°, 120°, 150° and 180° were afterwards used as giving approxi-

mately equal increments to L and M . The values of L and M for different positions of the tongue are plotted in Fig. 2.

The column headed M (computed) in the table gives the values of the coefficient of mutual induction computed from the values of the coefficients of self-induction of the two coils, according to the formula based on the assumption of no magnetic leakage:

$$M = \sqrt{L_1 L_2}.$$

The values of M thus computed agree very closely with the observed values.

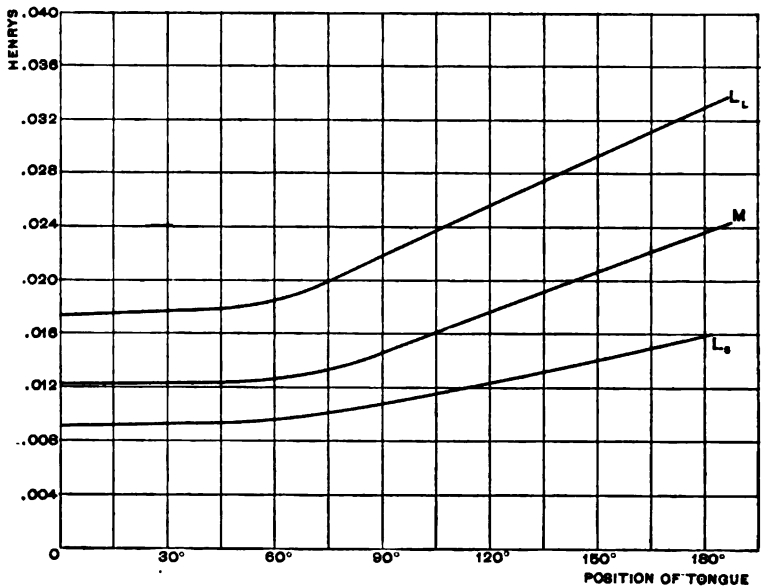

FIG. 2.—Variation of Constant.

The column headed $\frac{L_1}{L_2}$ gives the ratio of the coefficients of self-induction for the two coils, which we would expect to find equal to the square of the ratio of the number of turns of the respective coils, or

$$\left(\frac{128}{90}\right)^2 = 2.$$

The observed ratio approximates quite closely to this.

Experiments were made with the transformer on constant potential and also on constant current. The constant potential

circuit was supplied with a current of such a frequency that $\omega = 2 \pi n = 863$: while for the constant current, $\omega = 2 \pi n = 566$. In the table are given the values of the inductance obtained by multiplying the coefficients of induction by ω .

METHOD OF MEASUREMENT.

In the experiments proper with the transformer the connections were as shown in Fig. 3. In series with the primary was placed a non-inductive resistance consisting of incandescent lamps. The three-voltmeter method was used to determine the primary power and the angle of lag θ_1 between primary current

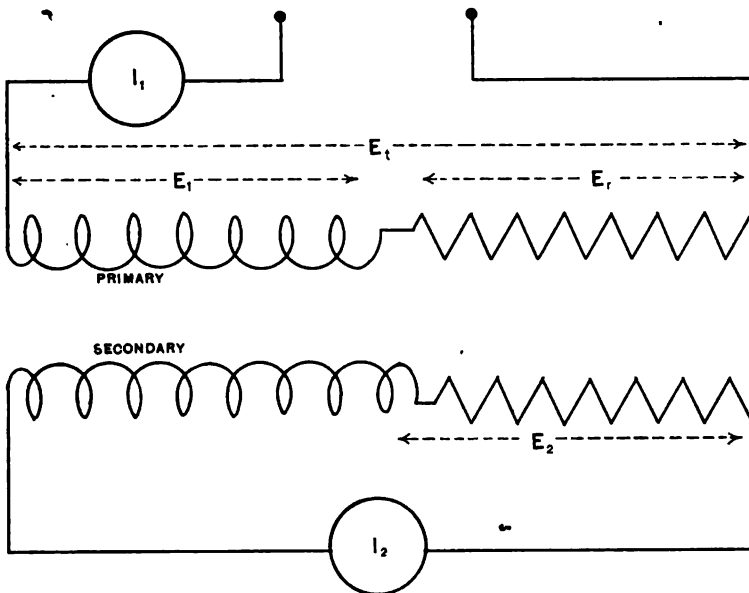

FIG. 3.—Diagram of Connections.

I_1 and electromotive force E_1 . This necessitated a measurement of the primary current, obtained by a Thomson balance, and the differences of potential between the terminals of the transformer, around the non-inductive resistance, and around resistance and transformer together. The secondary load was non-inductive, and the secondary current and electromotive force were measured directly.

The quantities observed in making the runs were :

E_1 —The E. M. F. around the primary.

E_r —The E. M. F. around the external resistance.

E_t —The total e. m. f. around the primary and resistance.

I_1 —The current in the primary.

E_2 —The e. m. f. in the secondary.

I_2 —The current in the secondary.

From these observed data the following results were computed :

θ_1 —The angle of lag between the primary electromotive force and current.

W_1 —The watts supplied to the primary.

W_2 —The watts in the secondary.

R_2 —The secondary resistance.

θ_2 —The angle of lag of secondary current behind the secondary impressed electromotive force. The primary angle of lag is calculated by the formula for the three-voltmeter method

$$\cos \theta_1 = \frac{E_t^2 - E_1^2 - E_r^2}{2 E_1 E_r}.$$

The primary power is $W_1 = E_1 I_1 \cos \theta_1$.

The secondary power is $W_2 = E_2 I_2$.

The secondary resistance, being non-inductive, is calculated by the fall of potential, thus

$$R_2 = \frac{E_2}{I_2}.$$

The tangent of the secondary angle of lag is

$$\tan \theta = \frac{L_2 \omega}{R_2},$$

from which θ_2 can be readily obtained.

CONSTANT CURRENT EXPERIMENTS.

The transformer was supplied in these experiments with a constant primary current, the square root of mean square value of which was $9\frac{1}{2}$ amperes, and the maximum value about 13.2 amperes. The frequency was such that $\omega = 2 \pi n = 566$. The transformer was used both as a "step-up" and as a "step-down" transformer. The step-up and step-down experiments were substantially the same, inasmuch as the ratio of primary and secondary turns was not far from unity in this paper; therefore, the results of the constant current experiments will be given for the step-down transformation only. A run was first made with the movable tongue secured by an arm in the zero position, that is, in the position in which the reluctance of the magnetic circuit is

the highest and the coefficients of induction the smallest. The secondary non-inductive load of incandescent lamps was then varied from short circuit to open circuit and the primary and secondary measurements taken as described for successive values of the secondary resistance. The tongue was then moved in and secured by means of an arm in the 70° position, and a complete set of readings again taken of primary and secondary for different loads. Runs were then successively made with the tongue secured at 90° , 120° , 150° and all in at 180° , and the same measurements taken.

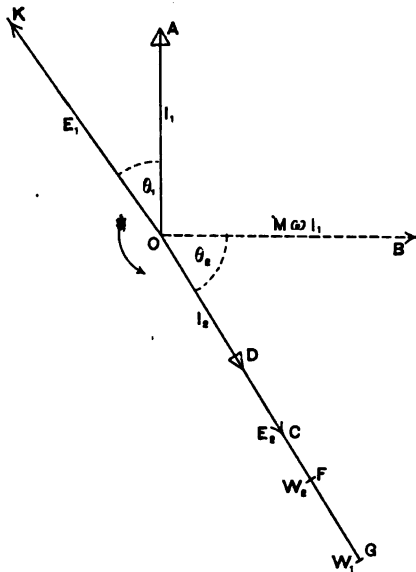

FIG. 4.

In this way data were obtained for all values of the coefficients of induction of the transformer, within the range of change produced by the moving in and out of the tongue, for all values of secondary resistance. For each observation, the primary and secondary currents and electromotive forces were known both in magnitude and direction—sufficient data for the construction of a polar transformer diagram. Such a diagram is represented in Fig. 4.

Polar Diagram.—In Fig. 4, the lines \overline{OA} , \overline{OB} , \overline{OC} , etc., represent the maximum values of the several harmonic electromotive

forces and currents in their relative phase positions. Rotation is counter-clock-wise about o. The instantaneous values of the currents and electromotive forces are equal at any instant to the projection upon any fixed line of reference, of the lines representing the corresponding maximum values. Closed arrows indicate currents and open arrows electromotive forces. \overline{OA} is drawn equal to the primary current, I_1 . The primary impressed electromotive force is in advance of the primary current by an angle θ_1 , and is represented by the line \overline{OK} drawn to any convenient scale. The electromotive force induced in the secondary due to the primary current is 90° behind the primary current. \overline{OB} represents this induced electromotive force, or the secondary impressed electromotive force. The secondary external resistance

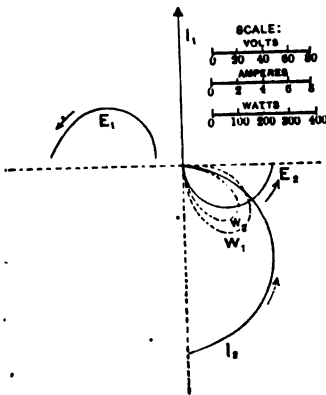

FIG. 5.—Constant Current, Step Down, Arm at 0°

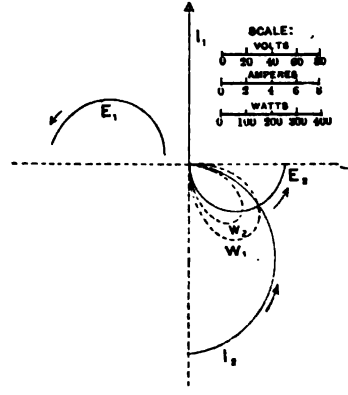

FIG. 6.—Constant Current, Step Down, Arm at 70°

is non-inductive and the current is therefore in phase with the electromotive force measured at the terminals of the transformer secondary, but the current and measured secondary electromotive force lag behind the secondary impressed electromotive force \overline{OB} by an angle θ_2 due to the self-induction in the secondary coil. The angle θ_2 is drawn so that $\tan \theta_2 = \frac{L_2 \omega}{R_2}$. The line \overline{OD} is drawn equal to the secondary current I_2 , and \overline{OC} equal to the electromotive force E_2 at the terminals of the secondary. As before explained, these lines represent maximum values.

The primary and secondary power, W_1 and W_2 , although not vector quantities, may for convenience be represented by the lines \overline{OG} and \overline{OF} drawn in the direction of the secondary current.

Diagrams similar to Fig. 4 may be drawn for each load of the transformer, the differences between these diagrams showing the effects of the variation of R_2 . When these diagrams are superimposed, with the lines oA for primary current coinciding, the variations in the different quantities are more readily observed by a study of the locus formed for each of the several quantities

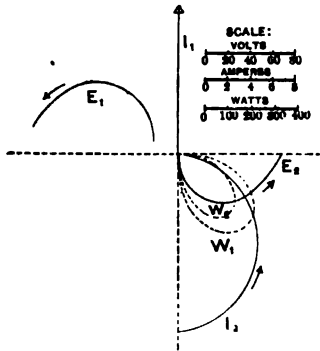

FIG. 7.—Constant Current, Step Down, Arm at 90°

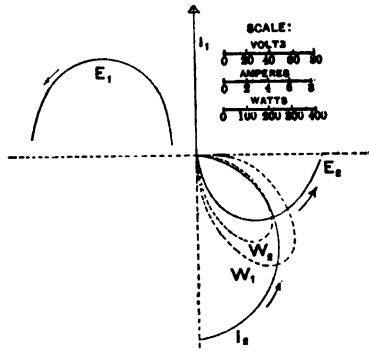

FIG. 9.—Constant Current, Step Down, Arm at 150°

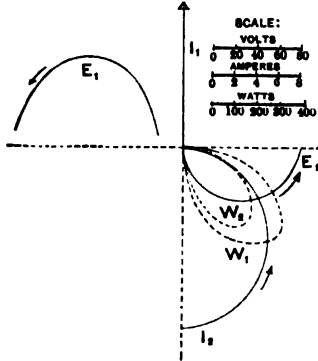

FIG. 8.—Constant Current, Step Down, Arm at 120°

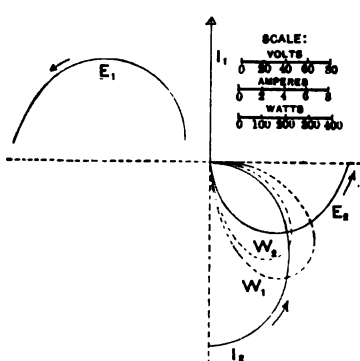

FIG. 10.—Constant Current, Step Down, Arm at 180°

that change as the secondary resistance is altered. It is in this way that the following diagrams are plotted. Fig. 5 shows the variation in the primary electromotive force, secondary current and electromotive force, and the variation in the primary and secondary power for all loads of the transformer, from $R_2 = 0$ to $R_2 = \infty$, for a constant primary current when the tongue is in the 0° position, that is, when it is all out. The arrows on E_1 , E_2

and I_2 indicate the direction of the change as the secondary resistance increases. Figs. 6, 7, 8, 9 and 10 are drawn in the same manner for other positions of the tongue. In all cases the primary current is constant.

The agreement of these curves with the theoretical is noticeable. The primary electromotive force curve and the curves for the secondary electromotive force and current are approximately semi-circles, as theory would indicate. The power curves, W_1 and W_2 , are symmetrical lobes at about 45° . The shifting of the primary electromotive force curve to the left is caused by magnetic leakage and is also in perfect accordance with theory, as given in the series of articles on the Theory of the Transformer already referred to, now appearing in the *Electrical World*. The

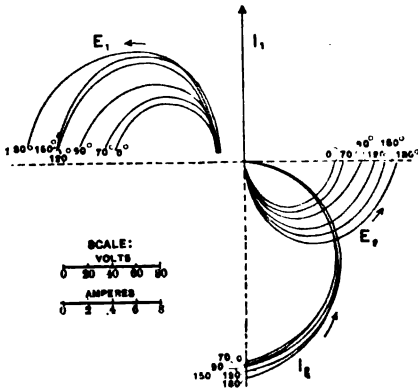

FIG. 11.

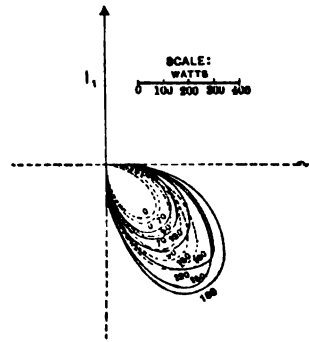

FIG. 12.

changes in the successive diagrams, from Fig. 5 with the tongue all out to Fig. 10 with the tongue all in, show the effects of diminished reluctance and increased coefficients of induction. The diameter of the semi-circle for the secondary electromotive force increases in direct proportion to the increase in the coefficient of mutual induction. The primary electromotive circle increases in proportion to the coefficient of self-induction of the primary. The diameter of the secondary current circle is nearly constant. The comparison of these curves is better seen in Fig. 11, in which the preceding diagrams are combined so as to show the successive changes in the currents and electromotive forces for different tongue positions. A composite figure is shown in the same way for the power curves, W_1 and W_2 in Fig. 12.

Rectangular Diagrams.—Rectangular diagrams do not indicate the direction of the quantities represented, but they show quantities in such a way that they are often superior to polar

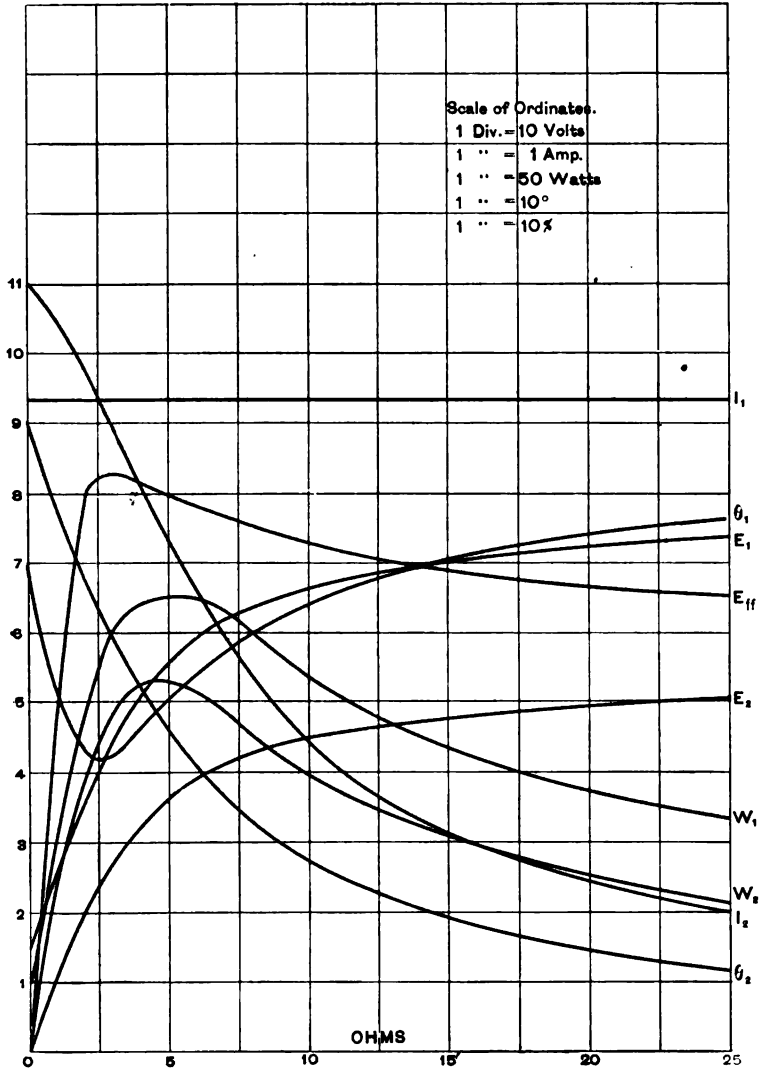

FIG. 18.—Constant Current, Step Down, Arm at 0°.

diagrams for indicating relative magnitude. For this purpose rectangular diagrams were drawn from the polar diagrams Figs. 5—10, and two of these are shown in Figs. 13 and 14, for the

tongue all out and all in respectively. These figures give the currents, electromotive forces, angles of lag, the power for the primary and for the secondary, and the efficiency of the trans-

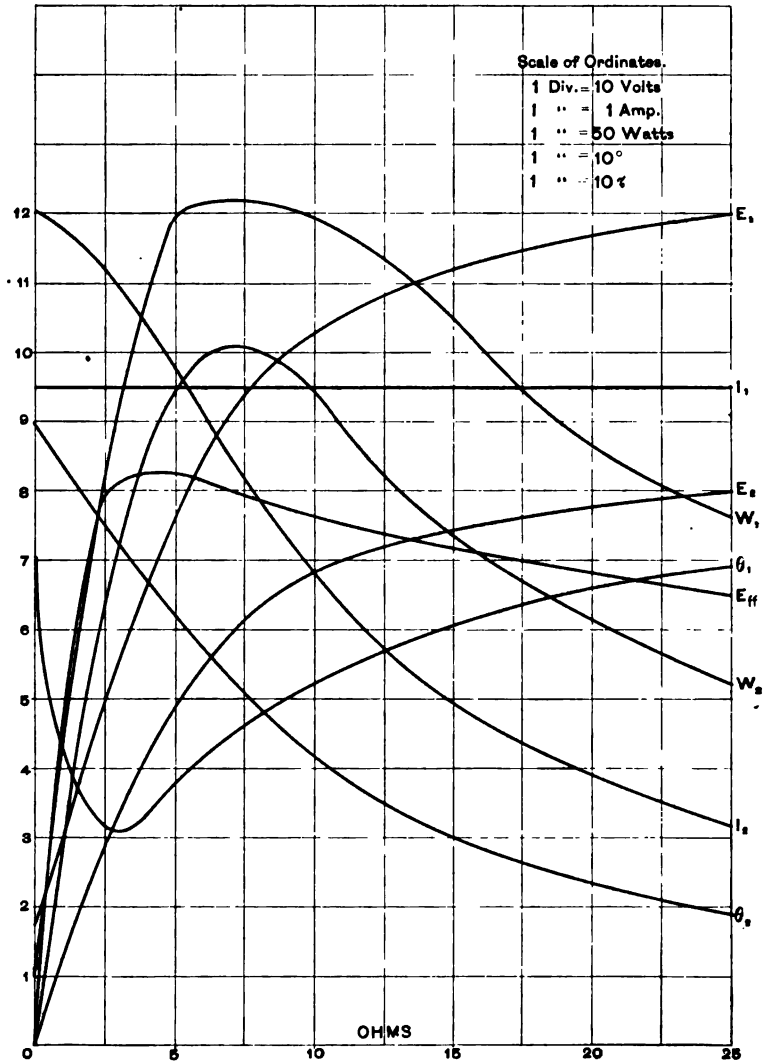

FIG. 14.—Constant Current, Step Down, Arm at 180°.

former for different values of the secondary resistance. The curves explain themselves. It is interesting to note that the primary angle of lag on short circuit has about the same value,

70°, for all positions of the tongue. As the secondary resistance is increased, the angle decreases at first and then increases again. A study of Fig. 11 will show that this is explained by the shifting of the primary electromotive force semi-circle in Fig. 11, to the left, due to magnetic leakage. If the leakage were dimin-

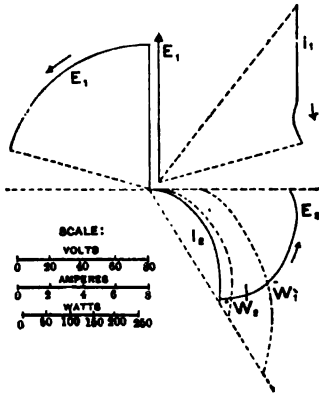

FIG. 15.—Constant Potential, Step Up, Arm at 0°.

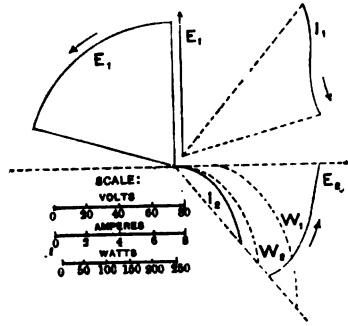

FIG. 16.—Constant Potential, Step Up, Arm at 70°.

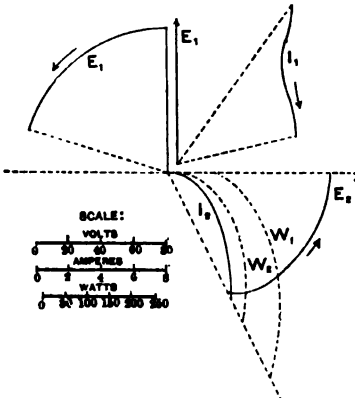

FIG. 17.—Constant Potential, Step Up, Arm at 90°.

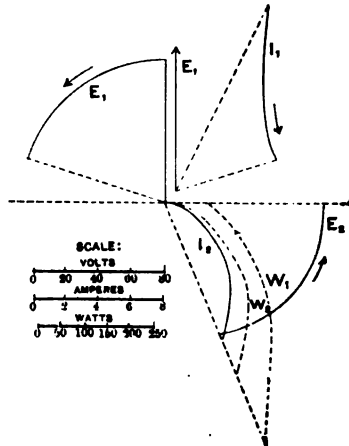

FIG. 18.—Constant Potential Step Up, Arm at 120°.

ished, the primary semi-circle would be moved toward the primary current $\circ A$. In the rectangular diagrams, a diminishing of the magnetic leakage would cause the minimum point in the curve for θ_1 to shrink and disappear in the case of no leakage.

CONSTANT POTENTIAL EXPERIMENTS.

Runs were made with the transformer supplied with a constant potential of about 62 volts (square root of mean square value), with the movable tongue secured in the different positions 0° , 70° , 90° , 120° , 150° and 180° as before. The electromotive force of the generator was about 110 volts, but varied a little, so that it was necessary to maintain the electromotive force supplied to the transformer constant by adjusting the non-inductive resistances. Measurements were made as in the constant current experiments, and the values of the various quantities obtained as before. From

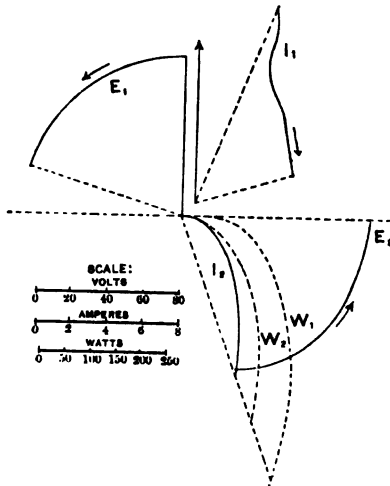

FIG. 19.—Constant Potential, Step Up, Arm at 150° .

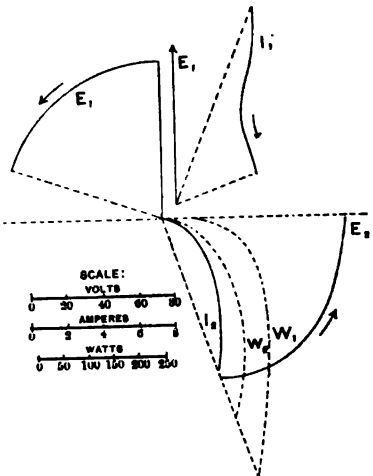

FIG. 20.—Constant Potential, Step Up, Arm at 180° .

these data, the polar diagrams Figs. 15-20 were constructed. In these the direction of the primary current is taken as vertical, fixed in direction, but varying in magnitude. The primary electromotive force is constant in magnitude, but varies in direction according to the value of the angle θ , between it and the fixed primary current. A diagram thus drawn does not show the changes in the magnitude of the primary current, and therefore an additional diagram is given in the upper right hand corner of each figure in which the primary electromotive force is constant both in magnitude and direction. The locus of the primary current in this supplementary diagram shows clearly the changes in the magnitude of the primary current as well as its

direction. As in all the polar diagrams in this paper, the loci are drawn to show the variation in the different qualities represented, caused by a change in the secondary resistance, the direc-

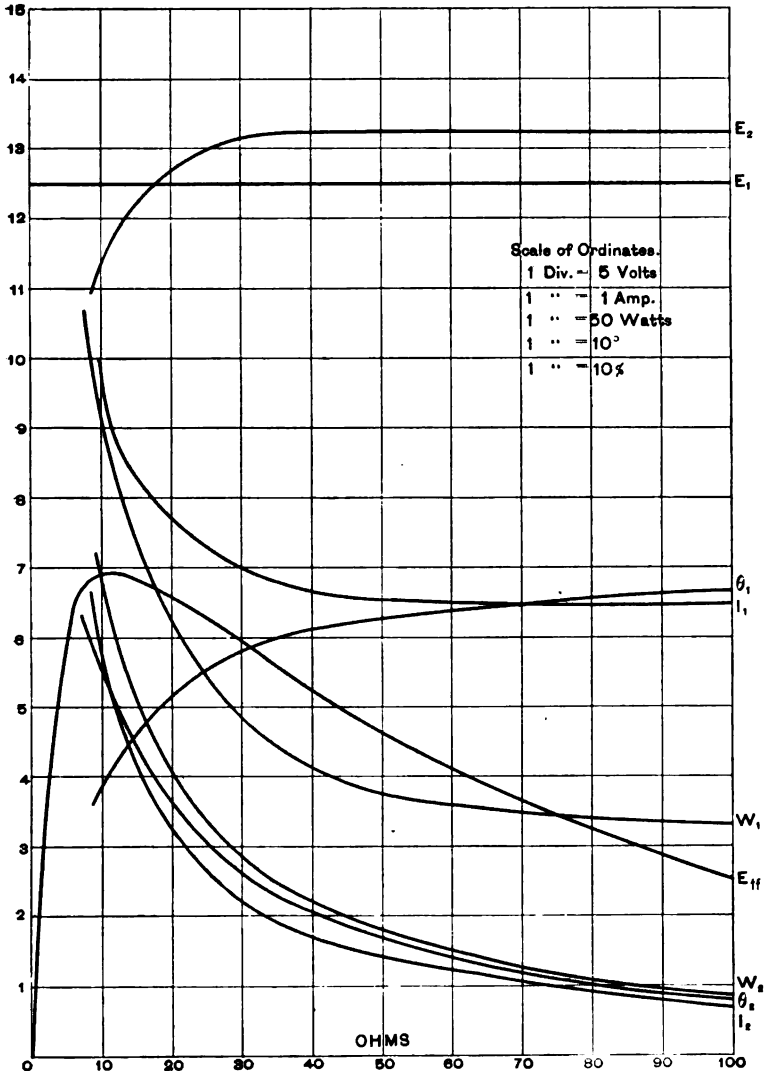

FIG. 21.—Constant Potential, Step Up, Arm at 0°.

tion of the variation with increased secondary resistance being indicated by an arrow.

Figs. 21 and 22 are rectangular diagrams, drawn from the cor-

responding polar diagrams Figs. 15 and 20, representing the relative magnitudes only of the various quantities.

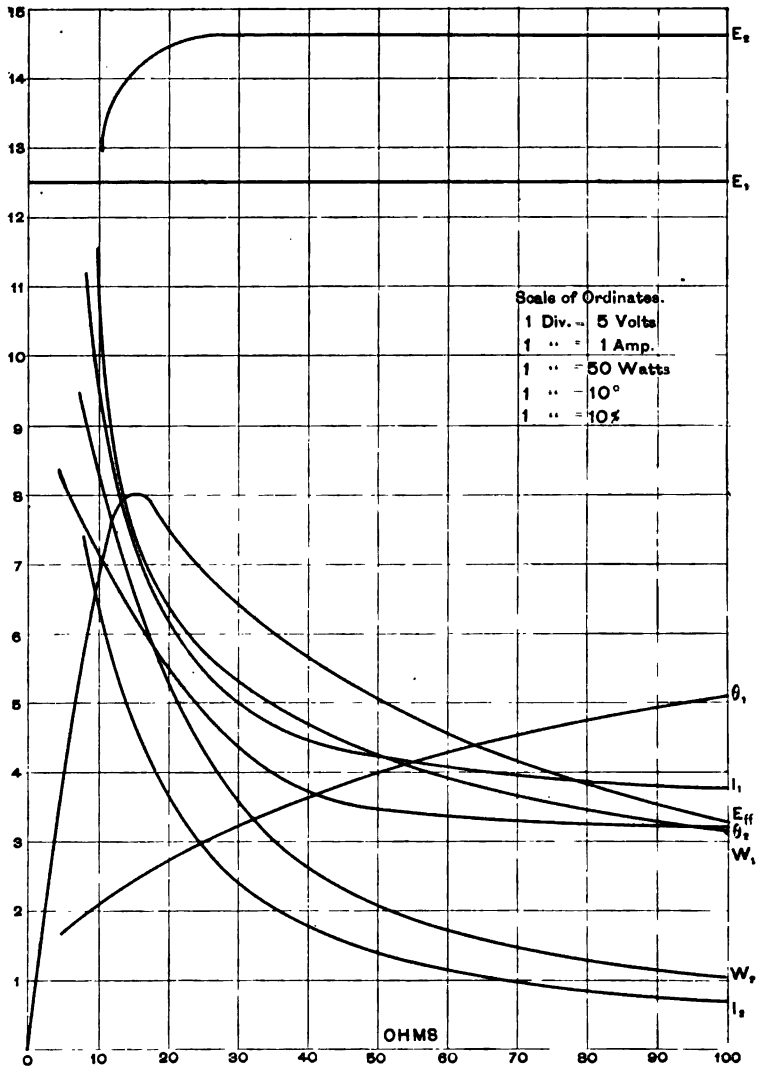

FIG. 22.—Constant Potential, Step Up, Arm at 180°.

CONCLUSION.

When this investigation was undertaken with a view of experimentally developing the method of polar diagrams just described, it was with a little uncertainty as to whether the method would

admit of ready practical application, and would give a clear exposition of the results obtained. It not only proves to be a convenient method for showing results, but tells the whole story in a comprehensive way, bringing out many points not otherwise shown. Furthermore, it proves valuable for comparison with similar theoretical work, based upon the assumption of harmonic currents, with which it agrees throughout, thus establishing the practical value of analytical treatment of problems with alternating currents.

The work was first taken up under the direction of the writer by Messrs. Berresford, Craft and Gherardi, as thesis* work at Cornell University. The investigation was conducted by them, and valuable assistance given by them in the preparation of this paper.

The curves here given are shown as representative and as illustrative of the method of showing the variation in certain quantities when one quantity is changed under certain conditions. Other curves were obtained, some of which showed the effects of the variation in the coefficients of induction, but those which are here described, showing the effects of a variation in the secondary resistance, have been given as being among the most interesting and instructive.

Cornell University, Ithaca, N. Y.

THE CHAIRMAN :—The paper is open for discussion. If there are no remarks to be made, we will pass to the reading of the remaining paper upon to-day's list, by Mr. A. E. Kennelly, on an Improved Instrument for measuring Magnetic Reluctance.

Mr. A. E. Kennelly then read the following paper :

*Thesis in Cornell University Library: "Effects of the Change of Reluctance in a Transformer."

ON AN IMPROVED FORM OF INSTRUMENT FOR THE MEASUREMENTS OF MAGNETIC RELUCTANCE.

BY A. E. KENNELLY,
Orange, New Jersey.

Of the methods that have been adopted for the measurement of magnetic permeance or reluctance of iron, the Faraday ring test with ballistic galvanometer is generally admitted to be the most accurate and reliable. It is, however, essentially a laboratory measurement requiring considerable time in preparation, execution and computation. For workshop measurements and comparisons, tractive and magnetometric methods have been employed with a convenience and facility usually obtained at some sacrifice in accuracy. Recently, instruments have been used with success in which the reluctance of a sample bar of iron is compared with that of standard bars of soft Norway iron, notably, the magnetic bridge of Mr. Thomas A. Edison, exhibited at the Paris Exhibition of 1889, and the differential magnetometer of Mr. R. Eickemeyer.* It is proposed to here describe a new instrument of this class, for which certain advantages may perhaps be claimed.

Fig. 1 represents the well known galvanic arrangement of circuits in which two resistances R_1 , R_2 can be compared by a null method. E_1 and E_2 are two equal and constant E. M. forces, inserted in the conducting paths AB and BC of equal resistance r . The galvanometer G , connecting the junction F of resistances with the junction B of electromotive forces, will indicate no current when R_1 and R_2 are equal. The conductor FB

**Electrical Engineer*. March 25th, 1891.

corresponds to the neutral wire of a three-wire system of electrical distribution.

Fig. 2 represents the corresponding condition of magnetic circuits. $A B C$ is a stout vertical frame of annealed Norway iron with two coils $M_1 M_2$ wound with the same number of turns of wire, connected in series so as to develop with regulated constant current strengths, equal definite $m. m.$ forces. The upright G corresponds to the galvanometer arm in Fig. 1, while the bars $A F$ and $F C$ are test pieces of iron having a cross-section considerably smaller than that in the remainder of the circuit. One, $A F$, suppose, is a standard section made up of one or more bars of soft iron whose quality is known, while the other $F C$ is the bar whose reluctance is required.

If the two reluctances $R_1 R_2$ are equal, the magnetic potentials at F and B will be equal, and the bar G will remain unmagnet-

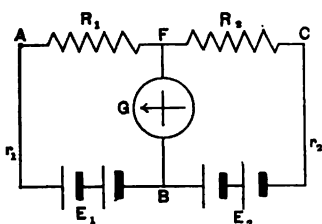

FIG. 1.

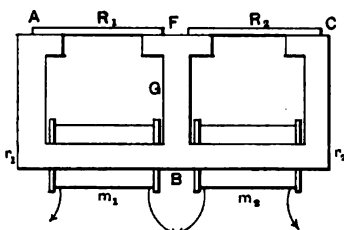

FIG. 2.

ized when the coils $M_1 M_2$ are excited. On the other hand, if R_1 and R_2 slightly differ, the potentials at F and B will not coincide, and magnetic flux will traverse the bar G . Since the magnetic circuits are all closed, the leakage through the surrounding air will be symmetrical and usually negligible, so that calling Φ the flux through the main circuit, and φ that through G .

$$\varphi = \Phi \frac{R_1 - R_2}{R_1 + r + 2G}$$

In order to ascertain whether flux did traverse the bar G , we might according to established principles,* cut in imagination an indefinitely narrow gap or crevice through G in a horizontal plane, and insert therein a magnet pole with apparatus to measure the tractive force to which it would be subjected. At the nearest practical approach to this plan we can cut a gap across

*Clerk Maxwell "Electricity and Magnetism." vol. ii., p. 896.

a $\frac{1}{8}$ in. (0.16 cm.) wide, and swing in the crevice a flat disk armature, carrying a steady feeble current and with an attached pointer or index close to a fixed scale. We then obtain in all essential features, the instrument here to be described.

Fig. 3 represents to scale in front and side elevation the actual instrument. *D* is the disk armature wound with 100 radial wires from center to circumference. Half of this disk is always covered by the pole pieces above and below it. The unifilar suspension attached to the points *p* and *q* supply a current of about ten milliamperes to this disk. A sensibly constant tension upon the suspension is obtained by means of a spiral spring within the lower slide tube, and it can be readily shown by experiment or computation that small variations in the tension

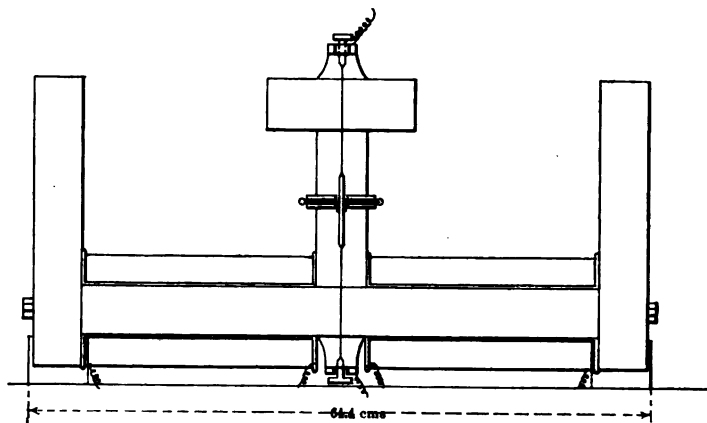

FIG. 3.

of such suspensions have a very small influence upon the torsional moment.

The modus operandi is as follows: A sample strip or flat bar of the iron to be tested is laid across the gap *F C*. The breadth of the bar being conveniently one inch (2.54 cms.) and the height $\frac{1}{2}$ " (1.27 cms.). Strips of soft iron to match this are laid across the gap *A F*, in parallel, each being, say $1" \times \frac{1}{8}"$ (2.54×0.318 cm.). If the disk circuit is then closed, and if there is no appreciable residual magnetism in the apparatus, the disk will remain uninfluenced and its index at zero. The field magnets are now excited in series with a suitable and measured current. The disk and pointer will now move to one side or the other about

the axis of suspension, according to the preponderance of reluctance between the two sides, and soft iron strips have to be added or removed across ΔF , until balance is restored. Generally, balance will be found between two adjustments of cross section, at ΔF , and the proper amount can then be computed by proportional parts.

Steinmetz has shown* that from a series of such adjustments to equality between standard and sample bars at various excitations, the complete hysteresis curve of the sample can be deduced through the known valuations of the standard, but, since a linear relation is found to exist between the reluctivity and magnetizing force in iron, above the critical intensity, two such observations are theoretically sufficient to determine the reluctivity of the sample for supercritical magnetizing forces.

The instrument can also be employed to readily indicate the retentiveness of sample bars of hard iron or steel. If after a balance has been obtained at a noted excitation, the excitation be withdrawn by interrupting the circuit of the coils $m_1 m_2$, and the standard bar is removed, the residual flux from the test piece will, disregarding some slight loss by leakage, pass entirely through the air gap and disk at D . If the constant of the disk has been determined independently, the deflection of the pointer for the observed current through the disk, will supply the amount of this flux Φ .

If N denotes the number of turns in each spool.

I the current strength exciting the spools (amperes).

l the length of the test bar (cms.).

g the reluctance of the air gap at the disk (c. g. s. units).

H_1 the magnetizing force in the bar during excitation.

H_2 the magnetizing force in the bar with excitation withdrawn.

Then the m. m. f. of excitation is $M = \frac{4\pi}{10} NI$ in each coil, and since the intensity in the test bar is considerable greater than in the field frame, the magnetizing force brought to bear upon the test bar is nearly $\frac{M}{l} = H_1$ (c. g. s. units). After removing the excitation and standard bar, the observed residual flux Φ , encounters at the air gap a reluctance g , so that neglecting the comparatively small hysteresis of the soft iron field frame, the

**Transactions of The American Institute of Electrical Engineers*, vol. ix No. 1, p. 38; January, 1892.

counter $m. m. f.$ at the gap Φg , (c. g. s. units,) representing an average demagnetizing force in the bar of

$$-\frac{\Phi g}{l} = -H_2,$$

so that the relative values of residual flux density are readily found with different sample bars for any selected value of H_1 , or more closely, for any consequent ranges of $H_1 - H_2$.

By mounting two opposed parallel plane iron plates between the uprights A and F , in such a manner that the length of air-gap between them can be adjusted by a screw, it becomes possible to measure the reluctance of a bar placed between F and C with direct comparison with the reluctance of air. Trial has shown, however, that the additional contact surfaces involved, the dissymmetry introduced into the two sides of the circuit, and the uncertain leakage error with large air-gaps, probably more than offset the advantage to be derived.

The errors attending the use of the instrument are:

1. The variability of reluctance in the field frame.
2. Errors in estimating the reluctance of the contact surfaces, and the effective length of the test-bar.

The first source of error depends upon the hysteresis in the iron of the field frame. It can be reduced to small limits by keeping the cross-section of the test-bar a sufficiently small fraction of the cross-section in the frame, thus bringing nearly all the reluctance of the circuit into the test-bar. A correction can also be made for the outstanding frame reluctance.

The second source of error is common to all forms of permeameters in which straight test bars are employed in closed magnetic circuits. There will be a certain range of reluctance in the contact surfaces that can be kept in subjection by giving to those surfaces adequate area. There is also the more complex error due to misestimation of the effective bar length, for the reluctance of the bar will not only be encountered in the distance between the supports F and C , but also by some portion of the length resting on the supports. The virtual length of bar included in the circuit will thus be a function of the intensity within it and will not generally be the same for the test and standard bars.

The advantages of the instrument are:

1. Absence of hysteresis in the moving and indicating parts, which contain no iron.

2. Great sensitiveness and control.
3. Small reluctance in the narrow air-gap or path of differential magnetization.

4. Convenience in comparing retentive powers in steel.

The dimensions of a completed instrument are appended in detail.

Core diameters.....	5.08 cms.
Core cross-section.....	20.8 sq. cms.
Uprights.....	5.08×5.08 cms.
Cross-section of uprights.....	25.81 sq. cms.
Disk diameter.....	7.6 cms. external.
Entrefer	0.16 cm.
Approximate reluctance of entrefer.....	0.00826 c. g. s. units.
Polar area above and below disk.....	approx. 20 sq. cms.
Mass of disk and pointer.....	28 grammes.
Turns on each field spool.....	3218.
Diameter of suspension wire.....	0.018 cm.
Deflection of pointer per ampere of current in disk, and per c. g. s. unit of flux through disk.....	0.8 degree.
Thickness of aluminium disk.....	0.085 cm.
Diameter of wire in disk radial winding	0.085 cm.
Silk covered to.....	0.042 cm.
Total thickness of disk.....	0.077 cm.
Mean clearance of disk in air-gap.....	0.0415 cm.
Winding 100 radial wires carried round on rim and reentering at common channel, never passing into air-gap.	
Available angular range of pointer.....	140 degrees.

The writer desires to acknowledge his indebtedness to Mr. Thomas A. Edison, in whose laboratory this instrument was constructed.

As there was no discussion on this paper, the Section adjourned until August 25th, 1893, 10 A. M.

FOURTH (FINAL) MEETING, FRIDAY, AUG. 25.

The section was called to order at 10 A. M. by the Chairman, Prof. Cross.

The Secretary then read the minutes of the meeting of Aug. 24, 1893, which were approved.

THE CHAIRMAN:—The first paper in the regular order assigned for to-day is by Prof. W. E. Ayrton, F. R. S., entitled "Variation of P. D. of the Electric Arc with Current, Size of Carbons and Distance Apart."

Prof. Ayrton then read the following paper:

VARIATION OF P. D. OF THE ELECTRIC ARC WITH
CURRENT, SIZE OF CARBONS AND
DISTANCE APART.

BY PROF. W. E. AYRTON, F. R. S.

The substance of the above paper was read by Prof. Ayrton, and a number of diagrams were shown. The manuscript was partially destroyed by fire through a most unfortunate accident. The paper embodied an exhaustive study of the forms of electric arcs and carbons under various conditions.

THE CHAIRMAN:—The next paper to be read is entitled, "The Light and Heat of the Electric Arc," by Prof. Violle, which will be read by him in French, and Prof. Silvanus P. Thompson has kindly consented to give an abstract of the same at the conclusion of its reading.

Prof. Violle then read the following paper :

LIGHT AND HEAT OF THE ELECTRIC ARC.

BY M. J. VIOLLE,

Professor in the *Ecole normale Supérieure* and in the *Conservatoire des arts et métiers.*

There is, perhaps, no manifestation of electricity which has given rise to so many investigations as the voltaic arc; investigations undertaken from the most widely different points of view, and leading to the most contradictory conclusions.

Finding myself favorably situated for studying some of the most important circumstances of this curious phenomenon, I have ascertained several facts which I will briefly relate.

The chief fact resulting from my researches is that the voltaic arc is the seat of a perfectly defined physical phenomenon: the ebullition of the *carbon*. This phenomenon is attested by the constancy of the brightness and of the temperature, as well as by all of the circumstances which characterize normal ebullition.

The constancy of the brightness had already been announced as very probable by Rosetti;* and in a note read before the Society of Arts, in London, Prof. Silvanus P. Thompson† had affirmed it as resulting from experiments, hitherto unpublished in part, by Captain Abney, explaining it by the volatilization of carbon. Moreover, all electricians had known for a long time, that the brightness of an arc lamp appeared to be independent of the power of the lamp, in the limits where the verification, necessari-

*Rosetti, Rend. Conti dell' Accademia dei Lincei, 1878-1879.

†Silvanus P. Thompson, Society of Arts, 1889.

ly rather superficial, could be made. I have found that the brightness of the positive carbon is rigorously independent of the electric power expended to produce the arc, operating within extensive limits :

Amperes.	Volts.	Watts.	Chevaux-vapeur.*
10	50	500	0.7
400	85	34,000	46

The experiments were made by two very different methods.

At first I operated with direct vision, by means of a spectrophotometer, which I had made by Duboscq, for the study of divers simple radiations of platinum at various temperatures†. This was a photometer which allows of equalizing with great precision, the radiation of a determined wave from two sources of light.

If one of the luminous sources is formed by the end of the positive carbon, the other consisting of the standard of light, the equalization once made, persists, notwithstanding the change which may be made in the current conditions of the arc, whilst the slightest difference brings about immediately the predominance of the wave of the other of the two systems of rays, which neutralize one another in the case of equality.

I then made photographs of the arc under different conditions of current, taking care to enormously diaphragm the objective and to limit the exposure to a very small fraction of a second. These photographs show that the brightness of the positive carbon remains identically the same in all cases, for the opacity of the sensitive stratum remains constant. I will add that according to experiments made since, by M. Blondel‡, the impurities which ordinary carbons of commerce may contain, do not alter the brightness of the positive crater.

One may easily account for this, if we remark that the impurities disappear by volatilization at relative low temperatures, it is carbon, exclusively, which boils at the positive pole.

Currents of air are usually a cause of error much more formidable. I avoid them by operating in the electric furnace to which I shall soon return.

If we take for a cathode a hollow carbon, we can demonstrate at the negative pole the condensation of carbon vapor, forming

*NOTE.—The French cheval-vapeur is equal to 0.9863 English H. P., or 736 watts. [Translator.]

†Violle, *Comptes-Rendus de l'Academie des Sciences*, 1879-1881.

‡Blondel, *Bulletin of the International Society of Electricians*, 1893.

on the interior of the tube a crystalline deposit, developing after the manner of electrolytic deposits of lead or silver, to disappear later when the cathode is sufficiently heated. In a general way one may judge of the temperature obtained in the furnace, by the simple aspect of the positive carbon which cleans itself the better the higher the temperature is raised; at the same time that the brightness of the positive carbon regulates itself to uniformity in a remarkable manner, the shape remaining perfectly clean cut and without trace of fusion.

Desprez* has without doubt exaggerated the fusibility of graphite at the ordinary pressure; but he was perfectly right, contrary to his contemporaries, when he affirmed for the first time the volatilization and condensation of carbon. I shall not cite those who until this day have sustained the inverse opinion, being willing to recognize in the consumption of the anode and enlargement of the cathode only a transportation of pulverulent carbon; especially for the reason that it will not perhaps be very difficult to establish concord between the two opinions.

I regard, nevertheless, that the conception of a veritable ebullition of the anode renders a much better explanation of the facts; it sustains also the idea of fixedness which is the characteristic of the phenomenon.

One result of this fixedness is the use of the positive carbon as a secondary photometric standard. M. Blondel has pointed out an ingenious way of realizing such a standard.

The determination of the temperature of ebullition of carbon is difficult. I at first endeavored to measure it by the calorimetric method, which has served for refractory metals. The electric furnace is then arranged in a special manner. The positive electrode is provided with a large tube, itself enclosing a second tube containing a rod terminating within in a button of the same diameter as the second tube.

When this button shall have reached the desired temperature, it will suffice to pull smartly on the rod to detach it. It will then be received in a little copper vase placed in the middle of the water of the calorimeter, brought beneath the furnace. The bottom of this copper vase is furnished with a disk of graphite; another disk is thrown by a turn-table on the button, itself transformed into graphite, as soon as the latter has fallen into the

* Desprez, *Comptes Rendus de l'Academie des Sciences*, 1849-1853.

vase; then the vase is closed by a cover. The heat brought there is then measured very easily by the usual process. With the enclosure due to M. Berthelot and a system of screens of asbestos pasteboard, one can almost completely keep off the radiation of the furnace and, at all events, to sufficiently reduce the correction proceeding from this fact, so that two experiments executed before and after the measurement, permitted the exact valuation of it. The loss of heat suffered by the button during its fall is very small; the opening of the little vase being brought to within 10 centimeters of the carbons, and the vapor of the arc enveloping the button during nearly the whole of its journey; it will be enough besides to vary the circumstances of the fall to estimate the amount of the loss. Also, by operating successively with buttons of different lengths, one will be enabled to determine the calorimetric effect which will be produced by a fragment of graphite raised throughout its mass to the temperature of the terminal surface. One can thus measure very exactly the quantity of heat carried to the calorimeter by one gramme of graphite at its temperature of ebullition. If we knew the specific heat of carbon in these conditions, we could easily decide from that the temperature desired. As this specific heat is not yet certainly known, we will regard as only approximate the number $3,500^{\circ}$, as I have advanced in a previous valuation.* I hope to soon be in a position to give a better determined result.

I have besides undertaken to measure the same temperature by a more direct method. I thus obtain a control always desirable in such difficult researches.

Does there exist in the arc, as Rosetti has maintained, a temperature notably higher than that of the positive carbon?

To discover this I have introduced into the arc a thin rod of carbon. This rod is consumed rapidly, being hollowed on the side facing the cathode and gathering a powdery deposit on the side facing the anode. In short, it behaves exactly like a metal wire in a galvano-plastic bath, following the law of Grotthus. Is there not, moreover, a true electrolysis in this depolarization, which, according to M. Berthelot, is produced at the same time as the vaporization of the carbon in the arc? In applying to the examination of the cavity offered by the rod, the methods which have served me for the study of the extremity of the positive carbon, I have found that the luminous brightness was the same

*Violle, *Comptes Rendus de l'Academie des Sciences*, 1872.

on the rod as on the positive carbon. After what has preceded this, one can comprehend how the furnace in which we propose to use the arc as a source of heat* should be arranged. The two carbons should be placed facing one another in such a manner that one may easily bring them nearer together, or move them farther apart. The most simple and convenient disposition is to place them at the same horizontal line.

To enclose the arc, so as to screen it as much as possible from exterior lowering of the temperature, and so as to utilize to the utmost the heat produced, the substance which was most convenient was that which Messrs. H. St. Claire, Deville and Debray have employed for their oxyhydrogen furnace.

The electric furnace reduced to its essential parts, consists then of two carbons fastened in a horizontal groove cut in a block of lime, which is conveniently formed in two pieces, one forming the groove and the other the cover.

But in this simple form the furnace has more than one inconvenience. To begin with, it is difficult to procure good pieces of unslacked lime. Then again, owing to the heat of the arc the lime dissolves and disappears rapidly. The first difficulty may be avoided by replacing, as has already been done by Deville and Debray, the lime by calcareous stone, (limestone). The second fault is suppressed by constituting the interior of the furnace of carbon.

Such are the dispositions that we have adopted, M. Moissan and I†, in the electric furnace which you may see at the exhibition.

This furnace is composed essentially of an enclosure of carbon‡ in the interior of which the electric arc spurts out between two horizontal electrodes. This enclosure has the form of a cylinder, whose height equals its diameter. It is formed of a fragment of carbon tubing, which rests at its lower extremity on a plate of the same substance. The upper part supports a disc of carbon having the same diameter. Finally, two hollows admit the electrodes. The cylinder is placed in a block of limestone from which it is insulated by an air space of five millimeters thickness; its base resting on wedges of magnesia.

The cylinders of carbon which serve for electrodes, are held by iron nippers resting on horizontal carriages which permit the

*Moissan, *Comptes Rendus de l'Academie des Sciences*; November, 1892.

†Moissan and Violle, *Comptes Rendus de l'Academie des Sciences*; March, 1893.

‡All of the carbon parts are made of agglomerated retort carbon, with tar

bringing together or the separation of them, at will. They receive the current through strong sleeves of red copper, armed with jaws, between which are crushed the ends of the dynamo-electric cable. This arrangement, devised by M. Tresca, is very convenient for the lighting and the handling of the arc.

The dimensions of the apparatus depend on the power at disposal.

For currents comprised between 300 and 500 amperes, we form the enclosure of a fragment of tubing of 6.5 centimeters diameter. We take as electrodes, carbons of 3 to 3.5 centimeters diameter, and the block of limestone is about 30 centimeters long, 20 wide and 25 high. The lid which has the same surface, has a thickness of four to five centimeters.

The available space is about 40 square centimetres, in which we can amass 40 horse power, which gives a very enviable return for the space occupied.

The Chairman then called upon Prof. S. P. Thompson, who read an abstract of the above paper in English, which is here omitted, as the translation is given in full.

PROF. ELIHU THOMSON:—I wish simply to add a few facts which have come to my notice in an experience with *nerosis* current. We are all acquainted with the subject of high temperature, and particularly that given with carbon. One of the experiments I wish to call your attention to is this: It was about 12 years ago. I took a small piece of carbon and set it between the carbons of the arc lamp and then increased the current to a certain extent and then kept on increasing the temperature until finally the piece bent around and dropped out. It was extremely brilliant and the radiant heat was very great. It was in the same state that the carbon is at the positive crater. Now another fact in the treatment of carbon. It has been proposed to make very slight rods of carbon by treatment in gasoline or other fluid. My associate tried to make solid carbon by the deposition of carbon, he found up to a certain limit the carbon was solid, but when he went beyond that limit it was very spongy. He started with very thin filament and he continued the treatment until it was finally replaced by very spongy carbon. The interior evidently had been drawn out and simply left such spongy carbon that it did not concentrate energy in the interior any further. Carrying out this general idea I conceived the notion of getting an electric furnace which would give a very high temperature which would carry the arc up to volatilization. This was accomplished by a little furnace with a rod running through the center ending in the heavy carbon with a conical opening entering through the ends of the box. I surrounded

this with a carbon powder assuming that this would be a very poor conductor, that is, broken charcoal, I then carried this up to a very high temperature. I found it was absolutely useless for the reason that there was a perfect boiling action of the powder as there was a perfect connection of the power passing through this hot rod and going up to the top and coming down; evidently the gases were coming around the hot carbon and dancing around and being replaced by new carbon, although protected underneath, the body burned away very rapidly. By looking in to the little holes that were like volcanoes, it occurred to me, we should not have this condition. So I modified this condition by sticking it together with a little sugar and then I found out that I could put in any amount of energy in that rod. I took iridium and ground it up and put it in to the little hole and I found there was no evidence of the iridium and nothing in the hole after the operation. We could take iridium and by very carefully measuring the temperature, mould it so that with perfect ease we could make iridium castings in that way. Furthermore, we could take pieces of sapphire and weld them together in this little hole so that the small pieces would stick and become like one piece. We found in this arrangement an ability to carry the temperature almost to the volatilization point.

PROF. WEBSTER:—I have often heard of the Thomson process of electrical welding and I am very glad it has been applied to sapphires. I have been very much interested in this paper and I should like to ask M. Violle one or two questions. I should like to ask Prof. Violle if he can tell anything about the thickness of the portion of the carbon which is in the boiling state. M. Violle said we must get the carbon a good deal cooler than the boiling point. It seems to me there must be a large difference between the greater part of that button and that which is really obtained.

MR. HINDRICKS:—I think that the determination of the boiling point of carbon is one of the most important physical data that have been obtained in recent years. 3,500 degrees C. as the boiling point for carbon is generally known. We know this as well as we know the boiling point of alcohol or water, but what is the melting point of carbon, that is not to be determined, I apprehend. The case is something like that of arsenic. Under ordinary pressure we can determine the boiling point of arsenic; we have arsenic in the solid state only by increasing the pressure, but I hope that brethren from France, who are distinguished by the utmost persistency and effort and wonderful skill, will also solve that problem by devising a means of obtaining the phenomenon under high pressure, then we shall have all the data of that wonderful substance, carbon. The getting of the physical data of the boiling of this wonderful substance has led to so much already, and has opened the fields of electro-metallurgy. I think this is one of the most interesting papers that we have had.

THE CHAIRMAN:—I will call next for a paper which is short and relates to the present subject in certain aspects, and I think it had better be read now than take its place on the programme. I will ask Prof. Silvanus P. Thompson if he will present his paper.

PROF. SILVANUS P. THOMPSON:—There are so many papers, that I should prefer to submit my paper to be simply read by title. I will state that this standard which Prof. Swinburne and myself proposed some time ago has come up in another form before the Chamber of Delegates.

ON THE SWINBURNE-THOMPSON UNIT OF LIGHT.

BY SILVANUS P. THOMPSON, D. SC., F. R. S.

In the Spring of 1892 it was independently proposed by Mr. James Swinburne and by the author of this note to adapt as a unit of light of standard quality the light emitted from a unit of area of the positive or crater surface of the electric arc formed between electrodes of pure carbon.

The advantages of this source of standard of illumination over all flame standards hitherto proposed are so obvious as scarcely to need mention.

The advantages over the platinum or Violle unit are also considerable. The carbon arc is much more easily managed, and if a pure carbon is employed, it is much more reliable as a standard than the mass of molten platinum.

The light of the electric arc is emitted, as is well known, chiefly from the end of the positive carbon, very little proceeding from the flame itself, and not much from the negative tip. The positive carbon is in fact heated intensely hot over a patch, from which the column of conducting vapor or flame (called by Davy the "arc") is projected across to the tip of the negative carbon. This luminous patch becomes hollowed out into a crater, white hot all over its surface, except at the edges, which are duller and redder, and which volatilize much less, but consume slowly by oxidation when the arc is produced in air. Except at these edge-parts the light of the crater-surface is of uniform lightness at every part if the carbon be pure. The reason of this circumstance is, as pointed out years ago by the writer, that carbon has a fixed temperature of volatilization. The arc cannot be formed at all unless this temperature is reached at least at some

portion of the surface; and the temperature cannot be exceeded at any point, simply because the volatilization of the carbon keeps it down. The temperature of the crater surface, that is to say, the temperature of the volatilization of carbon is as definite (if the material is pure and the external pressure constant), as is the temperature of the melting point of ice, or as that of the boiling point of water. It appears to be about 3500° C. All arcs made with a pure carbon, emit from the crater (save as regards the marginal parts), a light of equal whiteness, irrespective of the strength of current, or of the voltage, or of the length of the arc. Any variations that are noticed in the apparent colors of arc lamps arise either from the semi-incandescent parts around the edge of the crater, or from the tip of the negative carbon, or from the flame itself. If an arc has been burning for some time with a certain current (say, six amperes), its crater will have assumed a certain shape or size. If we now increase the current to 12 amperes, the incandescent surface of the positive carbon will be at once increased in proportion, save for a slight discrepancy arising from the marginal effect of the duller parts, and the enlarged crater will settle down to a new shape. (These remarks relate to the steady arc, the phenomenon of the hissing arc being still very obscure.) If then by proper shielding there can be cut off all the stray light of uncertain quality emitted by the red-hot margin of the crater, that emitted by the negative tip and by the flame, so that only the true crater-surface is visible, its whiteness, as so viewed through a hole in a suitable diaphragm, will always be of the same unvarying quality. This was the discovery of Captain Abney, F. R. S., in 1878; and it forms the basis of all the splendid work done by him in conjunction with Major General Fering, F. R. S., on the photometry of color.

Increasing the current merely increases the size of the crater, but does not alter its intrinsic brilliancy or its color. Increasing the voltage of the arc has no effect on the intrinsic brilliancy or color of the true crater surface. Increasing the length of the arc has no effect on the intrinsic brilliancy or color of the true crater. The amount of light emitted from a square millimetre of crater surface is a fixed quantity, no matter how the current, or the voltage, or the length, may be varied; and not only is the total amount of light emitted from a square millimetre constant, but its composition is constant. That is to say, the proportion relatively of red waves to blue waves, is the same always, independent of current, voltage, or length of arc.

It was in consequence of the recognition of these physical properties of the true crater surface, that the writer and Mr. Swiuburne, each made the proposition for the establishment of a new unit to supersede the Violle standard.

Since that suggestion was placed before the scientific world, some work has been done toward its realization. In France M. Blondel has described under the term *arc normal*, an apparatus closely resembling that used by Abney in his photometric researches, consisting of an electric arc furnished with a metallic diaphragm pierced with an aperture of known dimensions; but with the addition of a water-cooling arrangement. More recently, M. Violle has taken up the subject of the electric arc, and has redetermined the temperature of the crater. He adopts and confirms the author's view, that this temperature is determined by the volatilization of carbon. The author has also recently investigated the possible errors introduced by the thickness of the diaphragm and by an obliquity in its position; he has found these sources of error to be by no means negligible. He has also made some experiments on the purity of carbons, and finds that natural graphites always give a less light intrinsically than the artificially prepared hard carbons. Trotter, in his original investigation of the distribution of light as emitted from the arc lamp, announced the different emissivity of the soft carbons used for cores. He also investigated the amount of light emitted (normally) from a square centimetre of hard carbon, and found it to be something less than 70 candles, or about $7\frac{1}{4}$ carrels. Doubtless the imperfections of the photometric methods until recent years, were such that the production of an exact standard of white light was of less importance than is now the case, since photometry has become an art of precision. Professor Ayrton, adopting the periodic principle of photometry lately described by the author, and using a photometric screen of the Lummer-Brodhun pattern, finds no difficulty in measuring light with a precision of one part in 500. Now that such accuracy of measurement is possible, there is the more urgency for adopting a standard which is not only of entire trustworthiness, but is also easily reproduced.

As there was no discussion, the following paper was then read :

ON THE MAXIMUM EFFICIENCY OF ARC LAMPS WITH CONSTANT WATTS.

BY PROF. H. S. CARHART.
University of Michigan, Ann Arbor, Mich.

It is of interest to determine, in connection with the proposal to define a 2,000 c. p. arc light in terms of the watts expended on it, whether the illumination is independent of the current as a variable. If a 2,000 c. p. lamp shall be defined as one requiring 450 watts for its maintenance, shall the current be ten amperes and the p. d. of the arc 45 volts, or will a smaller current and a higher voltage give higher illumination?

The present paper can be considered as describing only a single step toward the solution of the problem, or a preliminary note relating to experiments conducted under one set of conditions. It seems quite clear that with any definite number of watts the candle power will be a function of the current, the size and quality of the carbons, and perhaps also of the source of the current, whether from a constant potential circuit, or from an open or a closed coil constant current machine. The experiments conducted by three of my pupils, Messrs. Raymond, Hookway and Fisher, have been confined to the circuit of a constant current dynamo with closed coil armature and to soft, plain carbon $\frac{1}{8}$ in. diameter, made by the Standard Carbon Company of Cleveland.

The method employed was as follows: With any constant current within limits a series of measurements of candle power was made by changing the length of the arc, and hence its p. d. A curve was then plotted with c. p., and volts as co-ordinates. Fifteen such curves were drawn for currents ranging between 6.75 and 10.75 amperes.

Then any number of watts was chosen, say 450, and this was divided in succession by the several currents used in obtaining data for the fifteen curves, or by so many of them as came within practical limits. With the potential differences obtained in this

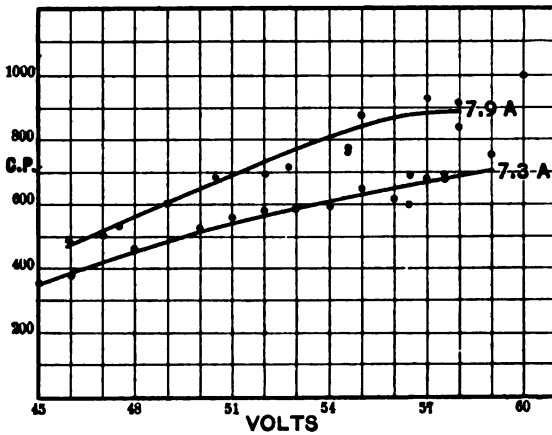

FIG. 1.

manner, and the corresponding candle powers read off from the several curves, another curve was constructed with candle power and volts as co-ordinates and with the watts constant. Such curves show a maximum point corresponding to the volts at

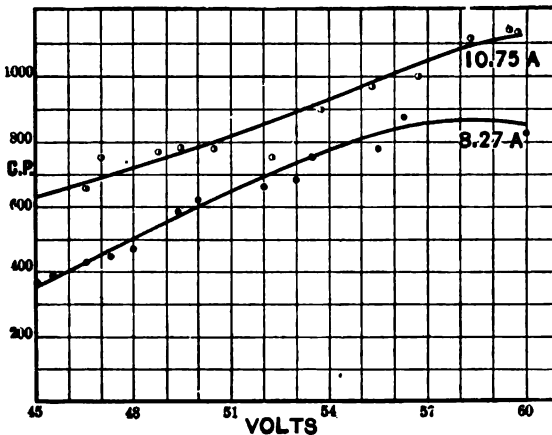

FIG. 2.

which the lamp gives the greatest candle power.

The measurements were all made in the photometer room with a 32 c. p. incandescent lamp as a standard of comparison. The arc lamp was mounted so that the arc was at the extremity of a

radius of half a meter, movable about an axis parallel to the photometer bar. The end of this axis carried a plate glass mirror from which the light of the arc was reflected down along the bar to the photometer box. The arc, or its image in the mirror, was thus kept at a fixed distance from the incandescent lamp, and its position was always such that the light came from the arc at an elevation of 45° . The absorption of the mirror was measured and found to be 8.7 per cent.

I have plotted only three of the fifteen curves composing the series. Fig. 1 contains two curves, with currents of 7.3 and 7.9 amperes; and Fig. 2 two others at 8.27 and 10.75 amperes, respectively. It will be seen that a maximum of only a little over 1100 candles was obtained. Fig. 3 contains the two curves derived from all the data, and with constants of 450 and 500 watts respectively. Both show a pretty well defined maximum at about 54 and 55 volts respectively. Hence for a lamp of 450

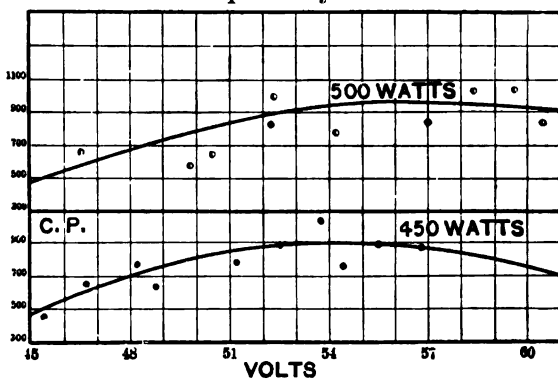

FIG. 3.

watts the current should be about 8.4 amperes with the carbons described above. The candle power was then 900. At 10 amperes and 45 volts this curve shows the surprising fact that the candle power was only 450.

With 500 watts the current rises to about nine amperes and the voltage to 55. I attach no great importance to these particular figures; but the series of experiments shows a very large variation of candle power, current and potential difference varying inversely, their product or the watts remaining constant. It is proposed to extend the investigation to other carbons of different size and quality, and to currents of an open coil machine; but enough has already been done to show that the definition of a 2000 c. p. lamp as one on which 450 or 500 watts are expended is not so definitive or unobjectionable as might at first be supposed.

The following paper was then read:

THE PERIODIC VARIATION OF CANDLE POWER IN ALTERNATING ARC LIGHTS.

BY BENJ. F. THOMAS, PH. D.,

Professor of Physics, Ohio State University, Columbus, Ohio.

It is well known that the intensity of the light produced by an alternating arc is subject to periodic variations, corresponding in frequency to that of the current maintaining the arc. Many curious optical effects may be observed in the neighborhood of such an arc, which effects are due to variation referred to, and to persistence of vision. If light from such an arc fall on rapidly moving machinery, as, for example, the fly wheel of a high speed engine, it frequently happens that the wheel appears to be moving more or less slowly in the opposite direction to that which one knows to be the true one. The explanation is obvious. If one move rapidly to and fro a narrow bright object, as the back of a knife blade, before an alternating arc, a number of images of the blade appear side by side. If the blade be so moved that the light proceeding from the arc to it, makes an angle of 30° to 50° with the axis of the arc, it will be noticed that the images forming a group are successively bright and faint, the images being separated by relatively dark spaces. The explanation is quite simple. The light which reaches the eye by reflection from the blade comes from the upper carbon point, and is brightest when that point is positive, fainter when it is negative and faintest when the current is passing through zero value.

Wishing to determine the character and amount of variation of light intensity during a single period, the following plan was devised by the writer during the Fall of 1890. The work was interrupted before satisfactory results were obtained, and was

taken up again this year by Messrs. A. H. Brown and J. J. Green, students in electrical engineering in the University. The results given below are taken from their graduating thesis.

A disk of blackened iron was so mounted upon the shaft of a small Westinghouse alternator as to allow the disk to be moved, while running, through small but equal angles about the shaft as an axis. The armature was of the Stanley arc light type, driven so as to produce a current having about 80 periods per second. At each end of a diameter of the sheet iron disk, a radial slit, about two degrees in width, was cut. The arc was formed between two Carré cored carbons about eight millimeters in diameter. The carbons were placed in a vertical plane passing through the armature shaft, the common axis of the carbons being inclined about 45° to the axis of the shaft, and the arc formed at the level of the upper slit when vertically over the shaft. On the side of the disk opposite the arc, and at the level

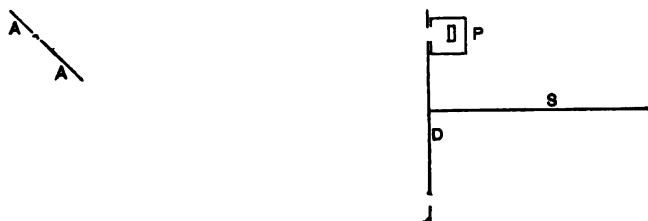

FIG. 1.

of the slit, a right-angled prism was placed, so as to reflect the light passing from the arc through the slits in the disk, to a Weber portable photometer. Slits in the box containing the prism allowed light to reach the photometer only at definite positions of the disk. Fig. 1 shows the arrangement of parts viewed horizontally, and figure 2 viewed from above.

$\Delta \Delta$ are the carbons, \times is the arc, s the armature shaft, D the disk mounted on it, P the prism, and w the photometer. Arrangements were also provided for taking current and potential curves by our usual contact method*, the contacts being so placed as to act only when light was passing through the disk to the photometer. The carbons were mounted on a special frame, both carbons adjustable by hand. A lens placed on one side formed an image of the arc on a screen, and when readings were being

*See *Transactions of American Institute of Electrical Engineers*, vol. ix, p. 267.

taken, the carbons were kept so adjusted that the arc was constant in position and length. In circuit with the arc was a Siemens electro-dynamometer, and a fairly non-inductive wire resistance of about eight ohms. The current strength was about eight amperes.

The apparatus being properly adjusted, the arc was established, and allowed to burn until the carbons were thoroughly heated. Readings of the photometer were then taken, with simultaneous readings of the contact apparatus for current and potential. The disc was then made to take a new position on the shaft, about $4\frac{1}{4}^\circ$ from the former, by means which I will not attempt to describe here. It is sufficient to say that the change could be made in less than a second, without in any way interfering with the

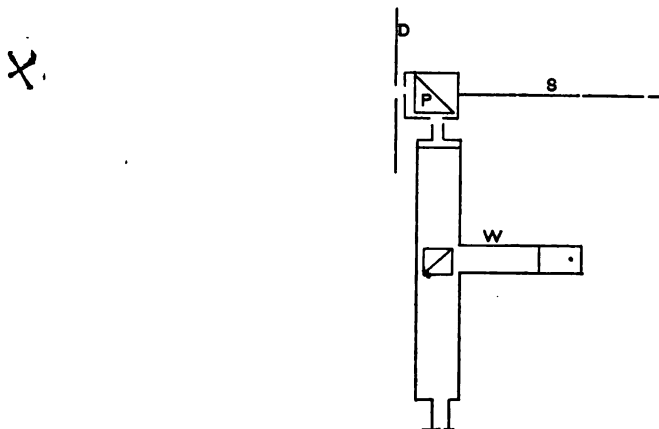

FIG. 2.

motion of the armature, and that the several positions of the disk were perfectly definite and well known. The change of $4\frac{1}{4}^\circ$ between two settings, corresponded to a change of one-twentieth of a period in the part of the curves being measured. Readings with the disk in the new position were taken, another setting of the disk made, and so on, until readings through an entire period had been taken.

On plotting the readings, it was found that all exhibited the same general features, though they did not all agree in values, owing to the want of entire constancy in the behavior of the carbons. Fig. 3 is an average of all curves taken. *l* is the curve of light intensities, *c* of current strengths, and *p* of potential

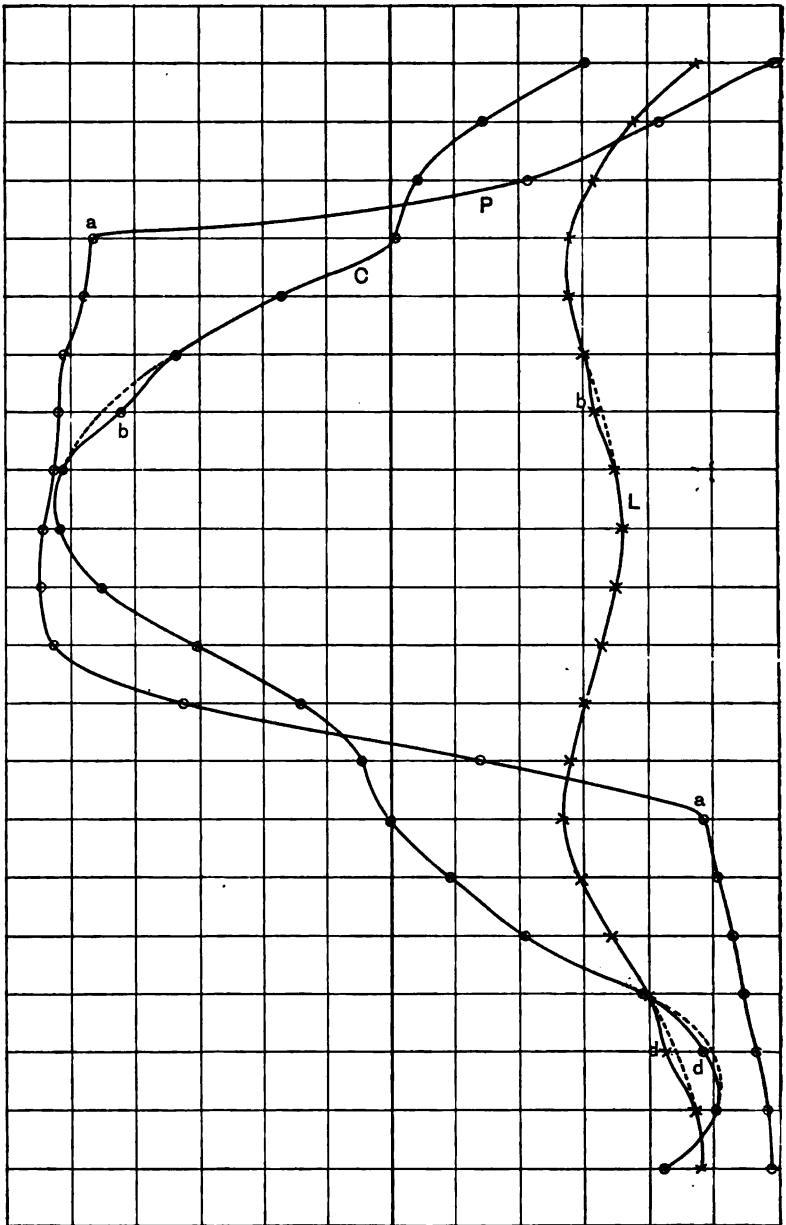

FIG. 3.

differences between the carbon points. The scales are arbitrary, giving relative values only.

The curves of current and potential difference are similar in general form to those found by others under somewhat similar conditions.* The principal difference is found in the part of the P curve, which follows reversal (*a a* of curve). In these curves the potential rises, at a uniform rate, from the point *a* to the beginning of the following reversal, instead of decreasing, as in the work cited.

The light curve L confirms the explanation given for the appearance observed on moving a knife blade under the arc. The light intensity is a maximum when the upper carbon is positive, less when it is negative, and is a maximum when the current passes through zero value. The difference between the maximum and minimum is less than expected, and may be found to be actually greater than the curve indicates. Prof. Nichols has shown† that photographs reveal the periodic extinction of the alternating arc. Fig. 4 *a* of his paper shows the images of the carbon points, as well as of the arc between them. In that figure the lower points in the second and fourth images are clearly brighter than the upper. In the third image the upper point seems somewhat brighter than the lower, as it should be. The original photograph will probably show the difference more clearly.

The points *b b* and *d d* in curves L and c of Fig. 3 are interesting. The dotted lines show the form of a smooth curve passing through adjacent points. The points *b* and *d* on the c curve show that the current strengths at those points were below the values which would have been found on a smooth curve. These departures from a smooth form were noted at the points indicated in all curves taken, and are characteristic of the machine and circuit as used. The corresponding points on the L curve show departures from a smooth curve at the same instant, and in the same direction. We may therefore say that, in the experiments described, at least, a change in the instantaneous value of the current strength flowing in the arc, when the current is more than half its maximum value, is accompanied by a corresponding change in the intensity of the light emitted by the arc. Moreover we may say that, so far as these experiments show, the time required to effect a change of light intensity, after the change in

*Tobey and Walbridge,—*Transac. Am. Inst. E. E.*, vol. vii., p. 367.

†Nichols,—*Transac. Am. Inst. E. E.*

current strength which causes it, is less than the $\frac{1}{1000}$ part of a second (the time represented by one division horizontally on the curves.) This surprising result strengthens the opinion that only an extremely thin layer of the carbon points can go through the temperature changes which must accompany the observed change in luminosity. If this were not so, the light changes at *b* and *d* would either not have been observed at all, or there would have been a noticeable lag or displacement in time, as compared to the current changes.

The Secretary then read the list of the papers to be presented by title, which are herewith given in full :

NEW RESEARCHES ON THE ALTERNATING CURRENT ARC.

BY A. BLONDEL.

Engineer, Dept. of Roads and Bridges, Paris, France.

I. EXECUTION AND CLASSIFICATION OF THE EXPERIMENTS.

Objects of this Study.—In an earlier paper,* the author had studied the optical effects presented by the alternating current arc and analyzed its manner of formation and extinction. Later on he returned to the question from an electrical point of view, in a series of experiments whose first results have been briefly reported.† He now proposes in this communication to furnish new experimental data, sufficiently copious for a more thorough understanding of these phenomena; and with this end in view he has taken the periodic curves of a large number of arcs under different conditions, so as to show the parts played by the variable factors of the problem.

Method Employed.—The first condition to be filled was that of great rapidity in the determination of the curves, for the most interesting phenomena, those of the hissing arc, are essentially changeable, and it is difficult to maintain the same adjustment for any length of time, in lamps regulated by hand, as was necessary.

To this end the author had recourse to an apparatus recording simultaneously, by the aid of photography, in about one and a half to two minutes, the two curves indicating the quantity of the current, and the difference of potential between the points of the arc. This apparatus comprised two portions:

*Lumière Electrique, Dec. 19, 1891, and Jan. 18, 1892.

†Société Française de Physique, April 1, 1892.

First. A *stroboscopic measuring apparatus*, which having been previously described*, will not again be referred to here.

Second. A *very simple photographic recording apparatus*, described in some detail below, which can be applied to all stroboscopic methods.

It consists essentially of a drum fixed rigidly on the axis of the movable arm of the contact maker and turning with it. This drum, placed in a *camera obscura*, carries the sensitized paper on which the variations of the measuring instruments are inscribed. It suffices then to slowly turn the movable arm by hand, or by the aid of clock-work, to obtain on the drum at one and the same time, the periodic curves of the tension and of the strength of the current; and one can plot on the same sheet, afterward, as many curves as may be convenient, thereby much facilitating comparisons. The photographic process thus presented possessed, besides rapidity several important advantages: it dispensed with a numerous staff; (the author made these measurements with the aid of a single assistant, M. Guilbert, Electrical Engineer); it avoided certain errors of reading, particularly those resulting from variations in the speed of the alternator, as these latter were recorded, and it was therefore easy to make allowances for them; it gave also a precision to the form of the curves which would have been difficult to attain otherwise.

It should be added that the greater number of these photographic records has been made with incandescent lamps, in broad daylight, not in a laboratory, but in the midst of a central station* which was in no way altered in its arrangements for the experiment, by the side of dynamos, and within three meters of the principal shaft of a 25 horse-power steam engine in movement. It is readily seen that photography, under these conditions, is a process exceedingly easy to manage, and only those who are unfamiliar with this sort of investigation would renounce the advantages it possesses.

**Lumière Electrique*, Aug. 29, 1891, p. 401. This method has some inconveniences, the principal ones being the difficulty of obtaining a good insulation and of adjusting the contacts exactly simultaneously. It is, in many ways, inferior to the ingenious method described later by Mr. Duncan and now employed in preference by the author.

Nevertheless it has certain advantages which justified its employment in the case under consideration; it was an improvement on earlier methods; it allowed the determination with rigorous precision of the exact time of the measurement; and it allowed the use of the Deprez-D'Arsonal galvanometer, of which the period of oscillation may be so easily regulated and so easily deadened.

*The Central Station of the Electric Lighting Company, at Paris; the first institution to apply alternating currents industrially.

The periods of the swing of the galvanometer needles employed were limited and regulated by methods devised by the author, and described elsewhere,* applied in such a manner as to avoid all errors due to the inertia of these instruments.

PRELIMINARY EXPERIMENTS.

The second condition to fulfil was to precisely determine the parts played by the conditions of production in the alternating current arc. With this end in view, the author undertook to determine what influence the particular machine employed could have on the arc, making comparative trials with five different machines:

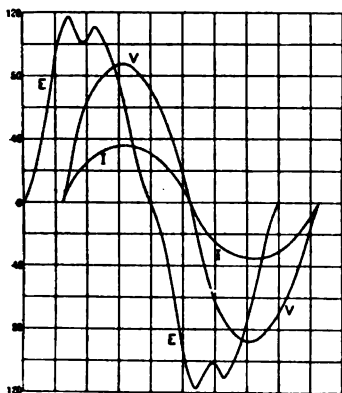

FIG. 1.

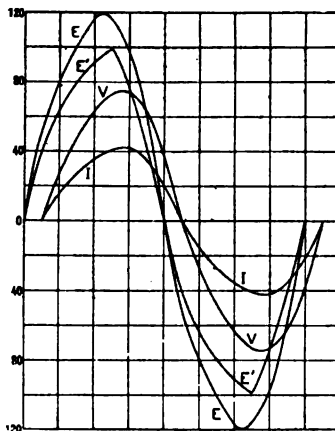

FIG. 2.

1st. An iron De Mériten's magneto-electric machine, of which Fig. 1 represents the periodic curves, on non-inductive resistances;

2nd. A Siemens machine, having a very low internal resistance and self-induction;

3rd. A Siemens-La Cour machine similar to the preceding, but having a very great internal resistance and self-induction (see Fig. 2);

4th. An old Gramme machine, four lamp type (see Fig. 29), its curve of tension on dead resistance;

* *Comptes Rendus* de l'Académie des Sciences, May, 1893, No. 15, p. 748.

5th. A La Cour alternator, with toothed armature, type 1893.* (See Fig. 3, its periodic curves.)

These comparisons gave the following results :

The influence of the law of variation of the electromotive force is nearly negligible so far as the difference of potential at the terminals of the lamp is concerned ; it is more noticeable on the curves of quantity.

For example, take the curves of quantity obtained in two series of similar experiments (the same carbons, the same length of time, and the same self-induction), made with machines 1 and 3. The curves have two general aspects, sufficiently differentiated. The difference is markedly visible in Figs. 20 and 31,

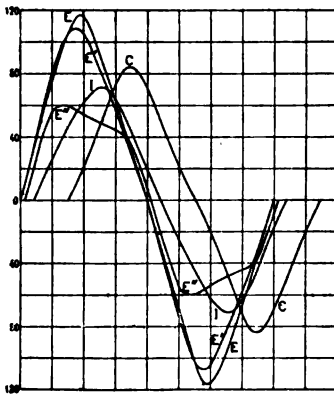

FIG. 3.

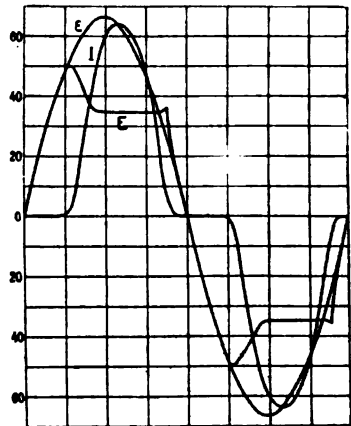

FIG. 4.

where the curves of tension are nevertheless nearly identical.

But that difference is entirely superficial and does not indicate a phenomenon sensibly different in the two cases, although we rarely have to deal with a form of E. M. F. so singular as that of the De Méritens machine.†

On the contrary, the introduction of increasing self-inductions

*The trials of the two latter machines were made by a different method, by means of newly devised apparatus, termed "Oscillographs."—*Comptes Rendus*, March 6, 1893.

†In general the self-induction of machines and other parasitic actions result in annulling, or at least reducing to a very feeble amplitude, the superior harmonics and to bring back the current and tension to a form very nearly sinusoidal.

into the circuit modified the very character of the periodic curves, as will be seen later on. A machine with strong self-induction gives different results from those of a machine with feeble induction.

The conclusion from this series of experiments therefore, was that it matters little in the general study of the phenomena what type of generator is used, and that on the other hand it is highly important to be able to vary at will the self-induction and the resistance of the circuit, while varying also the conditions of the experiments.

THE FINAL EXPERIMENTS.

The final definitive experiments were therefore made with the

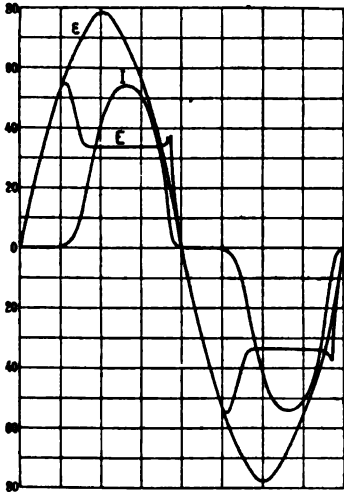

FIG. 5.

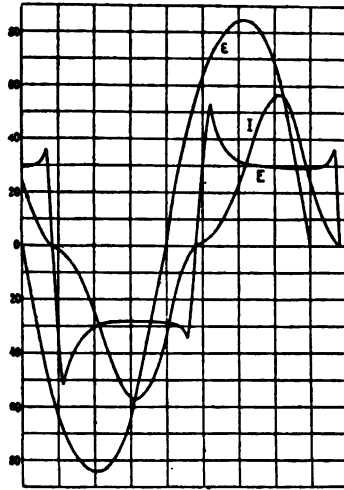

FIG. 6.

machine 2, of which the resistance and self-induction were nearly negligible, and which gave as its curve of *E. M. F.* a nearly perfect sinusoid, (while the machine 3 gave as may be seen in Fig. 2, a very deformed sinusoid).

They were executed with a frequency of about 52 periods. More will be said below on the influence of the frequency. The lamp was placed in immediate proximity to the machine, and it was possible, if desired, to reduce the resistance of the circuit to that of the small non-inductive rheostat used to measure the

quantity of the current. This rheostat formed of carbon rods presented a great cooling surface with a very low co-efficient of temperature; its resistance being only 0.05 ohms, the fall of potential caused by it was generally lower than one volt.

Beside this rheostat and the necessary connections for the stroboscopic apparatus, the installation comprised three measuring instruments: a Siemens electro-dynamometer, an Ayrton & Perry voltmeter, and a Zipernowski wattmeter.

Facilities were provided for introducing into the circuit between the machine and the lamp, a series of bobbins, whose

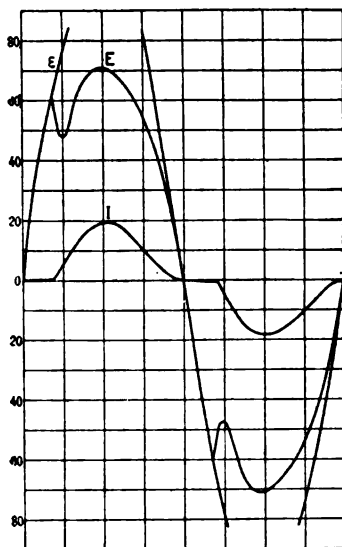

FIG. 8.

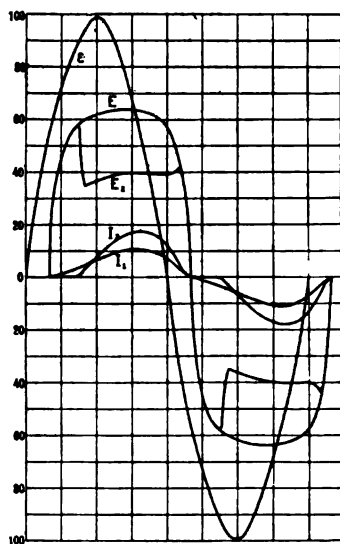

FIG. 9.

co-efficient of self-induction had been determined in advance, as were the measurements of the non-inductive carbon resistances; these reached 4 ohms and 0.02 henrys respectively.

To eliminate the resistance of the carbons and the lamps, very short carbons lightly coated with copper* were used, and a lamp adjustable by hand. Thus the curves of tension may be considered as taken between the very points of the carbons.

In only a few experiments, noticeably those with the

*The coating was so light that all of the copper was vaporized before reaching the arc; several comparative experiments demonstrated that it produced no cause of error.

Jablochkoff candles the resistance of the carbons was no longer negligible.

Variations within very wide limits were made, for each carbon, of the length of the arc, the electromotive force of the machine and the resistances or self-induction, introduced so as to analyze the influence of each one of these elements successively. The current strengths varied from 3 to 50 (effective) amperes. To avoid confusion in the interpretation of the results, it would be convenient to explain the terms employed below to distinguish the different species of arcs and of carbons.

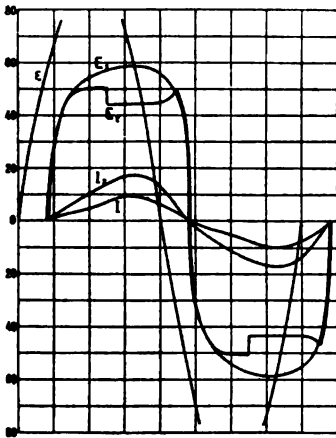

FIG. 10.

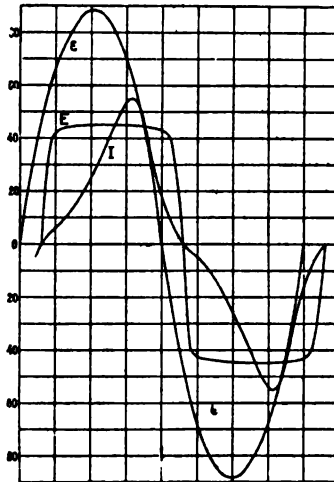

FIG. 11.

CLASSIFICATION OF THE SORTS OF CARBONS.

The carbons may be divided into two classes, homogeneous carbon, and wick (or colored) carbons.*

1st. Homogeneous carbons containing only nearly pure carbon.

In the trade they are separated into *soft* and *hard*, according to their rapid or slow consumption; but this distinction, though important as regards conductivity, consumption, photometric results, etc., is of no consequence as regards the electrical phenomena. Experiments in fact have not shown any sensible differences between the forms of the periodic curves, and in both

*For other details see the author's paper on "The Continuous Current Arc."

cases the vaporization of the carbon seemed to proceed in quite the same manner. No distinction therefore will be made here between hard and soft carbons, except in reference to certain details, such as that of disruptive tension.

2nd. Wick (or cored) carbons present a much greater variety: they are made of either hard-paste or soft-paste homogeneous carbons, to which have been added, after manufacture, a filling or core more or less thick, formed of a mixture of powdered carbon and various mineral matters susceptible of vaporization in the arc.

These filled carbons are to-day employed almost everywhere for the two rods of the alternating arc, they are usually made

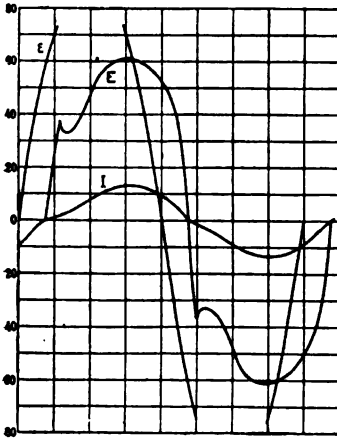

FIG. 13.

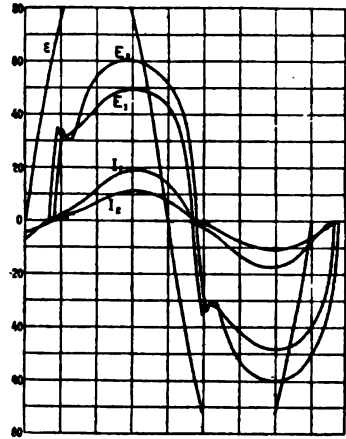

FIG. 14.

from hard paste so as to secure the maximum of conductivity.

The voltage necessary for the production of an arc is reduced by the use of the wick in proportions which depend on its composition, with a wick of high conductivity; an alternating arc may be produced with as little as 20 volts efficiency. The makers generally furnish two different qualities of wicks.

1st. High voltage wicks, requiring about 35 volts for an alternating arc of 12 amperes and 3 mm. length of arc, called for brevity *hard wicks*.

2nd. Low voltage wicks, requiring under the same conditions only about 28 volts, and called *soft wicks*.

These are two categories to which allusion will be made in

what follows, without noticing the nature of the paste (hard or soft), as the latter has no sensible influence in this case on electrical phenomena.

The experiments were based on carbons from three different makers.

1st. Carbons *C*, homogeneous, and with wicks, high and low voltage.

2nd. Carbons *L*, with wicks, high and low voltage.

3rd. Homogeneous carbons of the Jablochhoff* candle, *J*, separately or connected in the form of a candle.

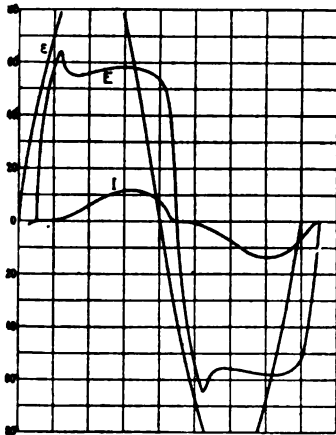

FIG. 15.

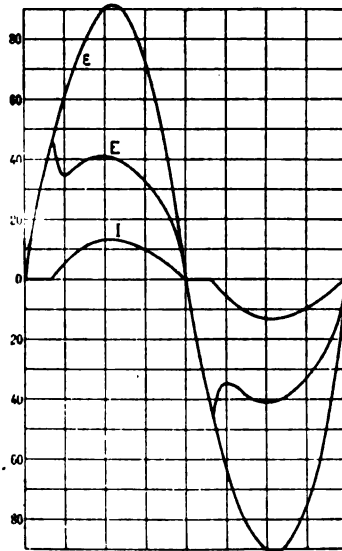

FIG. 16.

PHENOMENA OBSERVED WITHIN THE ARC.

For convenience in classifying and explaining the results, it will be well to indicate in this place the various phenomena, which we, judging by former investigations, believed might play some part in the alternating arc, and whose effects will be indicated in order to explain the conformation of the periodic curves. They are as follows:

First. The vaporization of the carbon at the surface of the positive electrode. It is known that according to the experiments of

* Manufactured at this time by the Electric Light Society, of Paris.

Messrs. Abney,* Rosetti†, Violle‡, etc., on the continuous current arc, the temperature of the positive crater of the arc is constant, whence the natural deduction is that the carbon on the surface of that electrode is in a state of ebullition. It was Prof. Silvanus P. Thompson § who first attributed the considerable fall of potential (about 39 volts), which is manifested at that passage to the work required by the vaporization, and that explanation seems perfectly rational.

Indeed, the transport of electricity by the molecules of carbon can only be effected by the detaching and pushing away of the

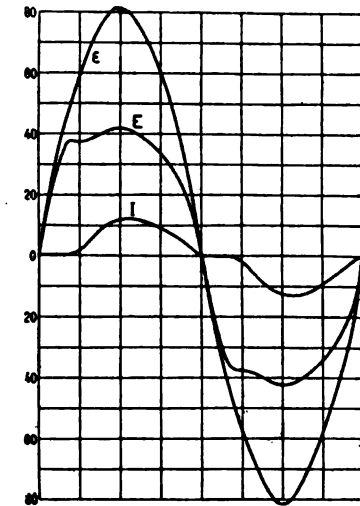

FIG. 17.

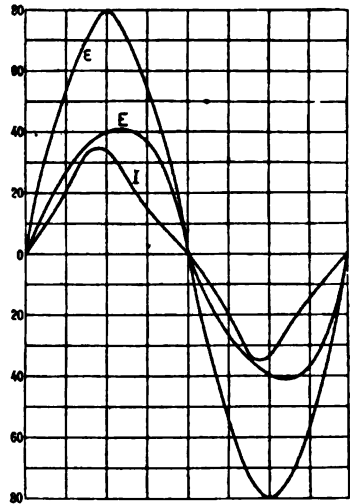

FIG. 18.

latter from the positive electrode, and the natural limit of this propulsion is vaporization, which requires a constant expenditure of energy and a constant temperature. This explanation, which will be adopted in the continuation of this enquiry, renders useless the hypothesis of a counter electro-motive force in the arc; besides, a direct demonstration will be given further on of the non-existence of the counter E. M. F.

The carbon vapor which is carried from the positive to the

* *Society of Arts*, March 6th, 1889.

† *Rendì Conti de l'Accademia dei Lincei*, 1878-1879.

‡ *Comptes Rendus*, January, 1873, and *Bulletin of the International Society of Electricians*, June, 1893.

§ *Society of Arts*, March 6th, 1889.

negative at a speed of which the author has approximately determined the value,* forms a bridge for the passage of the electricity. Certain experiments show that the conductivity of this bridge is unilateral;† therefore the transport of electricity should be the result of convection. Instantaneous photography also establishes the fact that during a portion, more or less important, of each period, the stream of carbon is interrupted.

Second. The detachment of carbon particles at the surface of the positive electrode. Vaporization is, as we have first seen, but

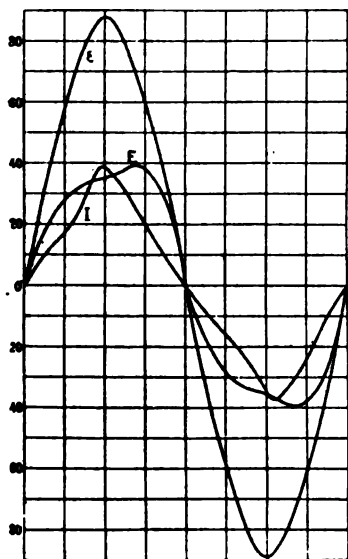

FIG. 19.

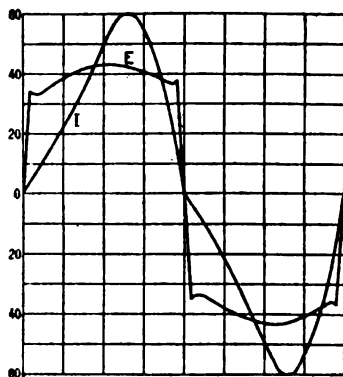

FIG. 20.

the limit of the propulsive effect; we should therefore admit, by analogy with phenomena proved to exist in the case of metals, that there may also be produced between two carbon electrodes disruptive discharges accompanied by simple molecular detachment and propulsion. It is, indeed, in this manner that certain authors* explain to this day the phenomena of the arc.

The author has elsewhere shown that it is easy to make a clear distinction between propulsion and vaporization, based on the

* *Lumière Electrique*, vol. 42, p. 619.

† Fleming,—*Lumière Electrique*, vol. 38, p. 365.

*Wiedemann. *Die Lehre von der Elektrizität*. vol. iv., 2d part, No. 1172.

No. of Dia-grams.	Kinds of Carbons.	Diameter in Millimeters.	Length of Arc in Millimeters.	Self-induction of the Circuit in Henrys.	Resistance of the Circuit in Ohms.	Induced e. m. f. in Volts.	Tension at the Arc Terminal in Volts.	Current in Amperes.	Actual Power in Watts.	Apparent Power in Watts.	Factor of Power.	Remarks.
4	Homogeneous C.....	10	2	0.0007	0.10	44.5	32.7	56.9	965	1,008	0.77	Hissing arc.
5	C.....	10	2	0.0035	0.40	55	34.3	30.2	720	1,035	0.70	"
6	C.....	10	2	0.0044	0.50	59.5	36.8	31	749	988	0.76	"
7	C.....	10	3	0.0044	1.00	56	40.7	14.3	440	575	0.78	Crying arc.
8	J candle.....	4	3	0.0007	2.70	72.5	53.3	11.1	409	602	0.91	"
9	J.....	3	5	0.0129	0.10	72.5	54.5	6.9	517	569	0.93	"
10	J.....	3	5	0.0129	0.10	72.5	38.5	10.6	316	411	0.77	"
11	J.....	3	1	0.0129	0.10	72.5	49.8	5.8	276	389	0.96	"
12	C.....	10	3	0.0028	0.10	63	42.6	11.5	452	490	0.93	Slightly hissing.
13	J candle.....	3	(0)	0.0038	0.10	52	40.8	30	1,063	1,224	0.88	Hissing arc, sticking together.
14	J candle.....	3	5	0.0153	0.10	73.5	31.8	29.8	814	949	0.86	"
15	C and J.....	3 and 10	5	0.0095	0.10	73.5	45.8	8.6	393	395	0.99	Asymmetrical crying arc. The tension curve is slightly as-
				0.0022	0.10	47.3	40	12.7	476	345	0.97	symmetrical.
				0.0121	0.10	67	52.7	7.1	336	374	0.84	"
	Wick (cored) Carbons.											
19	L.....	8	3.5	0.0007	4.00	64.5	32.8	8.5	250	280	0.80	
17	L.....	8	3	0.0007	4.00	57	32.9	7.4	211	239	0.88	
18	L.....	10	4	0.0007	1.00	56	29.5	20.8	584	679	0.95	
19	L.....	10	4	0.0007	1.00	60.5	26.2	22.2	616	648	0.95	
20	L.....	10	4	37	37.8	1,306	1,370	0.95	
21	L.....	8	3	0.016	0.10	50.5	28.8	6.8	184	196	0.94	
22	L.....	10	2.5	0.0007	0.40	49.5	24	36.1	27.9	1,006	0.93	
23	L.....	10	13	0.0045	0.10	40.5	30.7	18.2	354	355	1.00	
24	L.....	8	1	0.016	0.10	43.5	23.7	16.6	716	722	0.97	
25	L.....	8	4	0.0048	0.10	43.5	27.6	14.9	400	414	0.96	
26	L.....	10	2.5	0.0048	0.10	40.5	30.6	10.9	300	330	0.87	
27	L.....	10	9	0.0048	0.10	60.5	41.3	18.3	306	531	0.94	
			5	0.0007	1.00	60.5	31.8	16.5	562	592	0.95	
			12	0.0094	0.10	60.5	31.1	14.5	433.8	434	1.00	Tension at passage $T_A = 15.8$ v.
			12	0.0077	0.10	69	41.2	12.9	739.5	794	0.90	Fall of Potential of arc $T_a = 8.3$ v.

results obtained by instantaneous photography, and direct observation.

We find thus that the only arc in which vaporization proceeds in a regular manner is the *silent arc*, which is steady, and gives out a slight buzzing corresponding to the frequency of the current employed. This arc is violet and transparent; and can be obtained with more difficulty with homogeneous carbons, than with wick carbons.

When the arc becomes unstable, and gives out a *crying* sound, of the same fundamental note, but more strident, we are in the presence of disruptive phenomena; at each alternation the arc

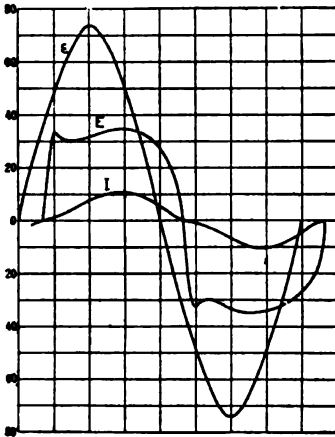

FIG. 21.

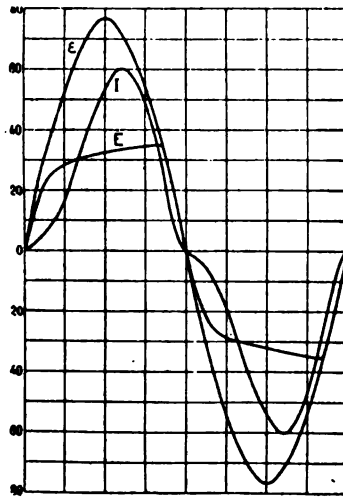

FIG. 22.

spurts suddenly in a direction nearly always away from the carbons, and which is often different according to whether the alternation is odd or even. This crying arc appears nearly always without any visible cause, particularly with homogeneous carbons and rather strong currents.

Finally when we bring the carbons nearly in contact the arc becomes *hissing*; it produces an acute sound and emits a green light like that of the hissing arc with continuous currents. By analogy with the latter, this phenomenon should be caused by irregular molecular detachment and propulsion. This is particularly noticeable with homogeneous carbons.

In what follows, this nomenclature to distinguish the three types of arcs will be preserved; but it seems more rational to classify the results in two categories, corresponding, one to the homogeneous carbon, and the other to the soft carbon. The arc between homogeneous carbons is, in fact, the genuine theoretical arc, freed from accessory phenomena; while the use of a wick, (or core), introduces modifications which often completely change its appearance.

Third. Conduction by hot gases. M. Blondlot has shown* that air at a high temperature allows the passage of electricity under a tension of less than $\frac{1}{10,000}$ volt, and that the apparent conductivity of this gas is due to an effect of convection.

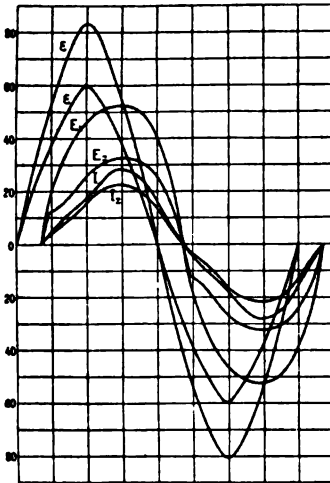

FIG. 23.

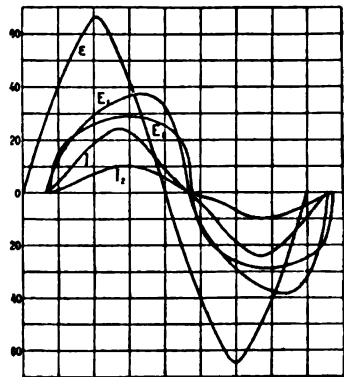

FIG. 24.

The same is true of a great number of gases, including oxide of carbon and carbonic acid, and recent researches of various experimenters† have established that convection is favored by a high temperature of the electrodes and by the ultra-violet rays, conditions which are both found in the alternating current arc.

No surprise will be felt, therefore, if during the interruption of the passage of the stream of carbon particles, conduction is

**Comptes Rendus* de l'academie des Sciences, 1887, vol. 104, p. 238.

†Hertz, J. Thomson, Arrhenius, Hallwachs, Righi, Stoletov, Bichat, Branley, etc.

established by the hot gases when the latter take its place and put in communication the sufficiently incandescent points of the electrodes.

Fourth. Conduction by saline vapors and particles of the core.

It has been proved, for a long time, that salts reduced to vapor, at a high temperature, conduct electricity. Without entering into the details of this phenomenon, still imperfectly explained, notwithstanding the recent inquiries of Messrs. James Thomson* and Arrhenius, we must attribute to it as has been stated above, the effect of the wick, acting conjointly perhaps with the carbon particles contained in it, and which may act by convection. These

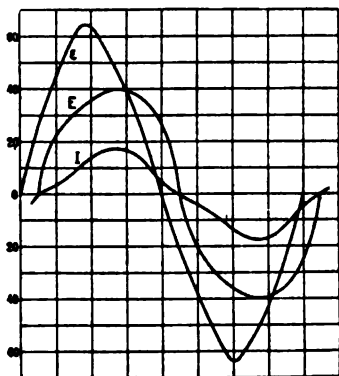

FIG. 25.

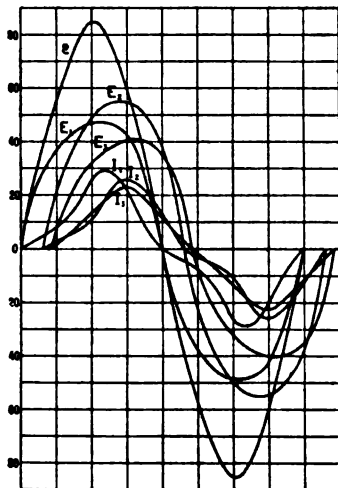

FIG. 26.

vapors seem to play exactly the same part as the carbon vapor, but as they condense only at a much lower temperature, they can maintain the passage of the current even during extinctions of the arc.

II. STATEMENT OF RESULTS.

The author will give here only a portion of the curves obtained, for many of the experiments have given results so little different, that space is wanting to reproduce them.

Each diagram comprises generally three periodic curves: the curve \mathcal{E} , which exhibits at each instant the E. M. F. \mathcal{E} induced in

**Philosophical Magazine*, 1890, vol. 29, p. 359-441.

the machine, called here the *available* E. M. F. The curve E , which exhibits at each instant the difference of potential e , between the carbon points, and which will be designated for simplicity the *tension* of the arc. The curve I , which represents the quantity of current i at each instant.

On several of the diagrams, several curves have been inscribed relating to the different circumstances.

At the bottom of each diagram has been noted the conditions of production of the arc; all of these indications are recapitulated in Table I, (page 290), which includes also the values of the current, of the tension, and of the energy both real and apparent, calculated from the curves in the ordinary manner. With this end in view, the author has, for each curve, divided each alternation

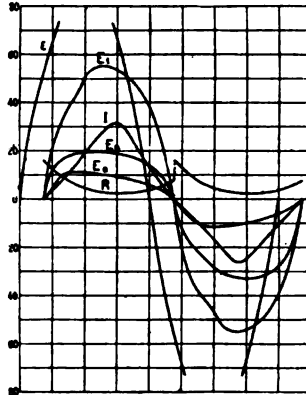

FIG. 27.

into 20 equal parts, and has measured the corresponding ordinates. By the aid of these ordinates, the following values have been calculated.*

$$\begin{aligned}
 E_{\text{eff}} &= \sqrt{E^2_{\text{mean}}} \\
 I_{\text{eff}} &= \sqrt{I^2_{\text{mean}}} \\
 P_{\text{apparent}} &= E_{\text{eff}} \times I_{\text{eff}} \\
 P_{\text{real}} &= (e i)_{\text{mean}} \\
 y &= \frac{P_{\text{real}}}{P_{\text{apparent}}}
 \end{aligned}$$

*These very laborious calculations have been worked out by M. Guilbert.

Curves Obtained from Homogeneous Carbons.—A singular characteristic of the alternating current between homogeneous carbons is the difficulty with which it is re-kindled. The formation of the arc after each extinction generally begins with a small disruptive discharge, requiring a tension superior to that necessary to maintain the arc. The phenomenon shows itself on most of the tension curves by a little beak which marks the moment of re-kindling, (Figs. 8, 16, 15, 6, 13, 14, etc.); in the other diagrams this beak is absent, especially when the length of the arc is small, and probably by reason of the conductivity of the hot gases.

The tension necessary to produce re-lighting of the arc increases with its length, (that is to say the distance between the carbons); it depends also on the shape and structure of the carbons

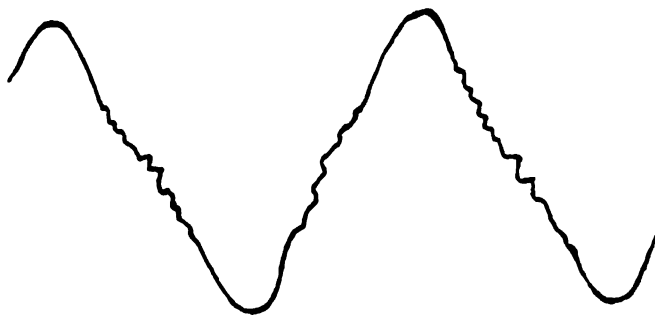

FIG. 28.—Record by the oscillograph of the extinctions at the same time as the quantity of the current of an alternating arc between 2 wick carbons.

employed, (contrary to what was observed in the production of vaporization); for example while 30 volts are necessary to re-kindle a Jablochkoff candle, at least 40 volts are necessary for the same purpose with hard homogeneous *C* carbons.

To assure the production of the disruptive spark, the machine must have an E. M. F. relatively high and it is necessary in consequence for the formation of arcs of average intensity to interpose in the circuit (as will be seen below in the article on *stability*) a source of self-induction, or a convenient resistance.

The effect produced by one or the other of these agents is seemingly equivalent, from the point of view of reduction of the mean efficient current; but not from the point of view of the form of the periodic curves; as will be shown in examining successively the results obtained when the circuit comprises practi-

cally only dead resistance, and then when it contains practically only induction spoils.

First. The non-inductive circuit.—The non-inductive resistance being unable to produce any unlocking of the current, the tension between the carbons tend to merge into the curve of the E. M. F. induced during the extinctions; that is to say over a certain length before and after the zeros of the E. M. F., as is shown in Figs. 4, 5 and 8. At the same time the quantity of current remains *nil* during an appreciable time (Fig. 8). This period of no current is especially well marked in arcs of feeble current; and in the *crying* and *hissing* arcs, the latter nearly always being the result of powerful currents.

The hissing arcs obtained by bringing the carbons almost into contact, differ from the others by the reduced value of the ten-

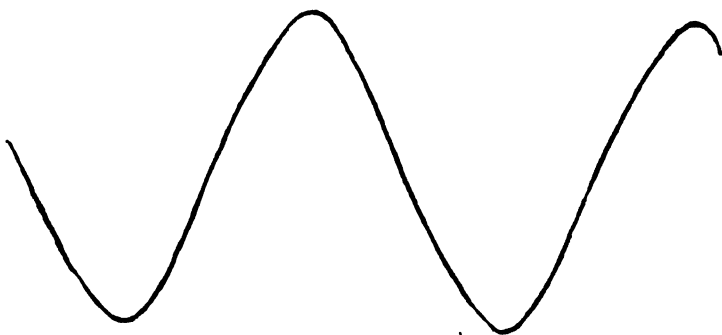

FIG. 29.—Quantity curve on dead resistance of a Gramme machine (4 light type) taken from an oscillograph.

sion during the passage of the current. The latter, which represents the effort necessary for the tearing away of the carbon is only from 25 to 30 volts, and remains rigorously constant from the first moment of lighting until the moment of extinction, indicated by another little beak. The latter should be found exactly on the curve of induced E. M. F. if the self-induction of the circuit was absolutely *nil*; but it was not entirely so in these experiments on account of the self-induction proper of the machine ($L = 0.0007$ henry); this explains the slight displacement of the beak towards the right.

As soon as the induced E. M. F. has fallen below the value necessary for the molecular detachment and propulsion, the latter ceases, the last molecules of carbon unite with the negative

electrode and the current absolutely ceases to pass until the following rekindling of the arc.

This seems to indicate that the gases, turned aside by the arc which forms all around the carbons, have not time enough during the extinctions to re-enter and become heated between the electrodes during the time the latter are near together, and thereby fulfil the function of a conductor.

When the carbons are further separated, the hissing disappears, the tension is raised and the extinction less sharply defined, owing probably to the effect of the heated gases. In the case of the Jablochhoff candle, (Figs. 8, 13, 14), the flame or the vapors of Kaolin prevent the conductivity from disappearing suddenly.

Besides, when the arc lengthens the tension whilst the current passes tends to present a form no longer rectilinear, but convex.

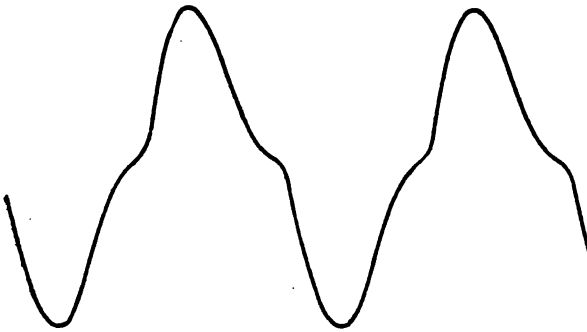

FIG. 30.

This effect is particularly marked with the Jablochhoff candles (Figs. 8, 13, 14), in which the arc has a bent shape and consequently great length; it exists even with candles coated with copper. It should then be attributed to the effect of the resistance of the arc itself, which absorbs an additional voltage increasing with the quantity of the current.

Second. Inductive Circuits.—The use of self-inductions in the circuit in place of resistances produces a retardation of the current on the E. M. F., which completely modifies the character of the curves.

The tension becomes liberated at the same time as the quantity and both continuing pass their zeros at the same moment, but during the extinctions the tension endeavors to overtake the induced E. M. F., and passes in consequence almost abruptly from

a high positive value to a high negative value, or *vice-versa*; the rectilinear portion approaching nearer to the vertical in proportion as the self-induction is stronger.

At the same time, and evidently owing to this effect, the period of no current disappears; instantaneous photography having shown that there is always an extinction of the stream of carbon during a noticeable time (see below, page 300), whence it is concluded that the conductivity is then maintained by the hot gases.

In some cases, nevertheless, a prolonged period of no current has been noted, particularly in the cases of hissing or crying arcs of feeble currents, such as that in Fig. 9.* But this is a rare exception, and in general the period of no current is only recalled to mind by a little angular point at zero.

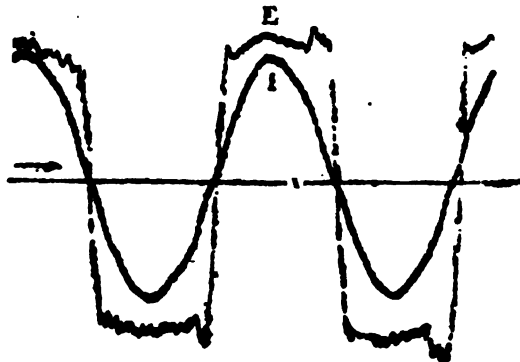

FIG. 81.

In certain cases one of these is quite noticeable, as in Figs. 20 and 13.

In other cases, particularly in the hissing arc, there are two of them joined together by a nearly rectilinear fragment of a curve (Fig. 9).

Finally, these angular points quite often disappear, and then there remains only a trace of them in the shape of a bend, as in Fig. 11.

These phenomena are interpreted further on.

* It will be noticed in the diagram referred to that the two curves of tension mingle at the outset of the alternation. One of them, corresponding to the regular vaporization of the carbon, continues its development in the usual manner, whilst the other suffers an abrupt depression at the moment the molecular detachment begins. The same remarks apply to Fig. 10.

The effect of the length of the arc is more perceptible in arcs on inductive circuits. The upper part of the curve of tension is inclined to a horizontal direction in proportion as the length of the arc is smaller; it is especially well marked in the hissing arc (Fig. 6).

The tension represented by this horizontal portion is only about 25 volts; but before and after extinction it considerably exceeds that value, forming two beaks, of which the most prominent is that preceding the kindling. These beaks are especially very marked when the arc is making a strident sound (crying arc).

When the length of the arc increases, the two beaks show a tendency to disappear (see Fig. 11), whilst the height where the

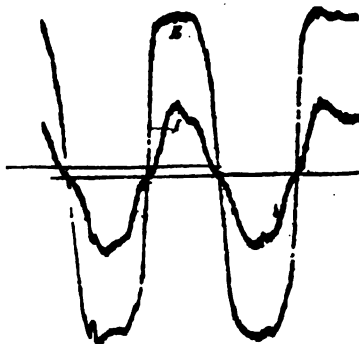

FIG. 32.

beak of kindling is produced augments rapidly, passing 50 volts in Fig. 15.

The horizontal portion also tends to become curved; the form more and more swollen, assumed by the curves, and which is especially marked with the Jablochhoff candles, should be attributed here as also above, to the resistance of the carbons, and especially to the great length of the space between them.

Curves obtained by wick carbons.—Wick carbons give origin to accessory effects which modify the phenomena above explained, and that to an extent determined by the conductivity of the saline vapors of the wick.

In fact, these vapors may offer, as has been said, a passage for the current even when the tension is insufficient to produce volatilization of the carbon; besides they aid in rekindling the arc at each period, making it much easier than with homogeneous carbons.

It is to this circumstance that we may attribute the regularity and stability of behavior, and the comparative silence of the wick carbons.

The periodic curves make this influence evident.

First. Non-inductive circuits.—Only arcs of very feeble current (below eight amperes), however, show great duration of the period of no current; moreover, the corresponding leaks of the curves of tension are slightly marked, often disappearing completely. Crying arcs, which are rare with this type of carbon show also more rounded forms than with homogeneous carbons.

Whistling arcs present perceptibly the same characteristics as with the homogeneous carbons, except that the rectilinear portion of the curve of current may be bent and less plainly marked.

As to silent arcs of a current greater than eight amperes, they show curves as much more rounded as the conductivity of the wick is higher, see Figs. 16, 17, 18, 19, 22. The curve of tension in Figs. 18 or 19, recalls nothing of the forms observed with homogeneous carbons.

The length of arc being the same, the efficient voltage diminishes as the conductivity of the wick increases.

Second. Inductive circuits.—The current is never annulled to a prolonged extent; the two curves of tension and of quantity disentangling themselves still simultaneously, but the tension curve, losing its rectangular form, is more rounded as the wick is a better conductor; Figs. 21, 23, 24, 25 and 26. The corresponding curves of the Figs. 24 and 26, represent the phenomenon as it is usually produced. The curves tend to approach a sinusoidal form, with this difference, that the curve of tension is generally more flattened, whilst the curve of quantity approaches readily a triangular form. In the majority of cases an angular point or a bend in the vicinity of zero recalls meanwhile, that an extinction has happened, entailing a change in the resistance.

COMPARISON WITH THE RESULTS OBTAINED BY OTHER METHODS.

In his photographic enquiry cited above, the author has already shown that the extinctions of the alternating arc are produced in all cases, but that they are disentangled and vary in length according to certain laws as functions of the quantity, of the length of the arc, and of the self-induction of the circuit. The periodic curves clearly explain these phenomena, particularly

that of the reduction in duration of the extinctions by self-induction. The reader may make these comparisons for himself.

In nearly all the curves obtained with homogeneous carbons, the moment when the current of carbon which constitutes the arc is established and is broken, is marked clearly by the form itself of the tension curve. But curves obtained from wick carbons do not give the same information.

To determine the points of kindling and of extinction, we should have to register on another drum fastened on the axis of the machine, a photograph of the arc by the method already followed.

The author has found the most simple plan to use this drum, (or another moved by any motor, whatsoever) for the recording of the curves of current themselves by a new method. With this end he has projected on the slit of the camera obscura of the drum, not the arc itself, but an image of it, formed by the small mirror of an oscillograph.* The latter is traversed by the current feeding the arc, and reproduces with sufficient accuracy its very rapid variations.

The curve which registers on the drum is then the periodic curve of the quantity of current itself. The depth of this curve according to the ordinates is at each moment proportional to the *breadth* of the arc at its centre, and the curve is interrupted at the same time that the arc is extinguished. Fig. 28 is the reproduction of one of the curves thus taken on a silent arc, with wick carbons, produced by a Gramme alternator. It shows that although the quantity varies constantly in the vicinity of zero, the arc is extinct before the current becomes *nil* and rekindles only after it has resumed a considerable strength. In this way an irreputable demonstration is obtained of the great conductivity of the saline vapors or the incandescent gases, during the extinction of the carbon current properly so called, which alone is sufficiently actinic to impress the photographic paper under the conditions of the experiment.

In replacing as the source of light the alternating arc, by a continuous current arc placed behind a vertical slit, the oscillograph has enabled us also to take off the current produced by the same alternator on a non-inductive circuit, Fig. 29, then in a

*The oscillograph, of which the author has recently given the description and the theory. (*Comptes Rendus de l'Academie des Sciences*, March, 1893, and May, 1893.)

hissing arc, between wick carbons, Fig. 30. The latter curve conforms to the types already described, provided the alternator has great self-induction.

Results Obtained by Earlier Experimenters.—The few results previously obtained by earlier experimenters are only isolated cases, which it is interesting to-day to classify under the series of types just described.

In his excellent paper on the Siemens machine, M. Joubert, without publishing the periodic curves of the arc, has attributed to the curve of tension a nearly perfect rectangular form.* This holds good for the employment of a machine with great self-induction, and homogeneous carbons or wick carbons of low conductivity. The author has succeeded in reproducing this form perfectly, with small wick carbons of low conductivity; but it is difficult to realize with certainty; it should be considered as an infrequent occurrence. The idea which has been held for some considerable time of making it a general type must therefore be renounced.

More recently Messrs. Tobey and Walbridget have published some curves of the arc produced by the Stanley alternator; unfortunately nearly all of them are disfigured by the resistance of the carbons themselves, and by the effect of the regulating bobbin of the lamp which gives rise to an apparent disruption between the tension and the quantity; the only one which really applies to an arc properly so called, is that which these authors have obtained while regulating the lamp by hand. It presents the two beaks noticed above and responds exactly to the type of Fig. 6; it shows in fact that the Stanley machine possesses a high self-induction and that the carbons used were homogeneous.

Factor of power.—The periodic curves permit the calculation of the factor of power with a greater precision than any other method; and to analyze the causes which modify it.

The factor of power is defined as the ratio:

$$y = \frac{(e i) \text{ mean}}{\sqrt{e^2} \text{ mean} \times \sqrt{i^2} \text{ mean}}$$

The value of y approaches nearer to accuracy as the number of ordinates measured on the curves is greater.

*Joubert : *Journal de Physique*, 1881.

†American Institute of Electrical Engineers, Oct. 21, 1890.

This calculation has been made by the author, aided by M. Guilbert, for a great number of groups of curves.

10 groups obtained with a Siemens La Cour machine	} high voltage and wick carbons (French light-house type).
8 " " " " De Méritens machine	
18 " " " " Siemens machine and carbons of all sorts.	

In the first series, not including any hissing arc, γ has varied between 0.76 and 0.98.

In the second series γ varied from 0.80 to 0.97 for non-hissing arcs and fell to 0.68 for two hissing arcs.

By way of verification the author has made, on arcs produced by these two machines, more than 50 measurements with a Siemens electro-dynamometer, a Cardew voltmeter and a Zipernowsky wattmeter; the results entirely agreeing with those furnished by the curves. The factor of power has seldom fallen below 0.70.*

Finally, the third series, made under more diverse conditions, has given more distinct differences. The curves here reproduced bear the indication of the factors of power, and the calculated results are recapitulated in the table.

It is seen that the feeblest factor 0.70 was obtained in the case of a hissing arc; which confirms a remark already made by Messrs. Ayrton and Sumpner.† But the cause of the phenomenon should not be looked for, as has been thought, in the separation between the quantity and the tension, the form of the curves suffices, as may easily be seen, to modify the factor of power within the widest limits. This factor is feeble in proportion, as the period of no current is prolonged.

The comparison of the effect of an alternating arc with an induction should therefore be expunged from manuals where it has been introduced, in consequence of a too frequent confusion between alternating currents in practice and theoretical sinusoidal currents. For the same reason the hope of preventing hissing by the use of condensers must be abandoned.

The minimum value, $\gamma = 0.70$, is greater than that pointed out by Messrs. Ayrton and Sumpner. These authors found ‡ (by a method perhaps less precise), figures as low as 0.50 for a fre-

* Some of these results can be found in *La Lumière Electrique*, vol. 42, p. 560, and vol. 48, p. 59.

† *Proceedings of the Royal Society*, vol. 49, pp. 424-439.

‡ *Proceedings of the Royal Society*, vol. 49, p. 431.

quency of 100; it seems possible that this difference may arise from the difference of frequency; it will be sufficient explanation to admit that the relative duration of the extinctions with the period of no current increases with the frequency. Remarks made further on concerning the stability will confirm this view.

Variation of the quantity and the tension with the length of the arc.—It is impossible to fix for alternating currents a relation analogous to the formula given for continuous current arcs

$$V = a + bl.$$

All depends in fact on the form of the periodic curves, which is continuously variable according to the conditions of production of the arc, and the kind of arc employed. For instance, two machines may require comparatively slight differences in efficient tensions to produce across the same distance between the carbons, arcs of equal intensity. During his experiments the author has ascertained that the Siemens-La Cour machine requires about one or two volts more than the de Mèritens machine, with the same carbons.

Distribution of Voltage in the Arc.—The author has endeavored to give some account of the manner of distribution at each moment of the difference of potential existing between the points of the carbons. To this end he introduced in the arc the extremities of two little carbon rods placed respectively as near as possible to the two incandescent carbon points. Then he inscribed successively on the same sheet, the differences of potential measured between the rods and the carbons.

The experiment, which requires rather a long arc, could only be made with soft wick carbons, for lack of sufficient voltage in the machine. The result obtained shows that the total difference of potential, divides as in the continuous current arc, into three descents of varying importance;* the greatest takes place at the surface of passage of the positive electrode, the same as in a continuous current arc; the second at the surface of passage of the negative electrode and varies nearly proportionally as the first; lastly, the third is due to the resistance of the arc itself and presents a rather angular zero at each change in the direction of the current.

The curves of fall of potential in the arc, and of quantity of current allow, by dividing the ordinates of the former by those

*Uppenhorn.

of the latter, the deduction of the law of variation of the resistance of the arc.

This as may be seen, passes by a minimum about the middle of each alternation, that is to say, when the current is at its maximum quantity, and shows a discontinuous variation each time the current becomes *nil*. The latter fact explains itself if we admit that the conductivity of the arc is a conductivity by convection, analogous to that of the air between two incandescent surfaces.

The researches of M. Blondlot* have shown that this conductivity proceeds from an emission of molecules of air charged with electricity at one of the electrodes and discharging itself on arrival at the other; and that the molecules leave the charged electrode with the greater facility as its temperature is higher. But at each change in the direction of the current the negative electrode is transformed into the positive electrode, that is to say, the charged electrodes; as at the moment of this change it is cooler than the other electrode, one can easily conceive that the number of molecules subject to convection diminishes abruptly, whence arises the augmentation in the apparent resistance of the arc.

The same explanation may be given to interpret the angular point shown at the zeroes of the curves of quantity in the case of wick carbons; Fig. 20.

Deductions Relating to the Theory of the Electric Arc.—It is established to-day that when Edlund discovered in the continuous current arc, a counter electromotive force capable of deflecting the galvanometer after the extinction of the arc, he was the victim of an experimental error. Yet many physicists have continued to admit the existence of such an electromotive force.

The curves reproduced here, taken as a whole, demonstrate in the most evident manner that there exists in the electric arc neither polarization nor electromotive force, in the ordinary sense of the words, or at least that their value is inappreciable.

In fact in the one or the other of these two hypotheses, there ought to be a separation of the quantity in proportion to the difference of potential at the terminals; that is to say that the two curves ought not to pass by their zeroes at the same time, as is the case on all of our diagrams.

* *Comptes-Rendus*, 1887, vol. 104, p. 283.

It is besides evident that according to all our knowledge of polarization, it could not exist in a gaseous medium at these high temperatures.

Influence of the Frequency.—The author has compared the preceding results, all corresponding to the frequency 53.3, with those obtained with a lower frequency, 25 periods only. The periodic curves taken have presented identically the same characteristics, besides he can see no cause which might operate to modify them.

The only points on which we should expect to feel the influence of the frequency are the factor of power, as has been explained above; and the stability, which will be treated below.

Stability of the Alternating Arc.—One of the most important practical questions is that of the steadiness of the alternating arc, that is to say, its resistance to extinction from accidental causes; currents of air, electrical oscillations, etc., in the circuit.

The mechanism of the lamp cannot and ought not to respond to abrupt variations, and it is wrong to attribute to that cause the frequent extinctions which really arise from the carbons or from the circuit.

The steadiness of an alternating arc is only assured when the disposable E. M. F. (induced E. M. F.) is sufficient to rekindle the arc with absolute certainty at each alternation, and when at the same time the duration of the extinction is not sufficient to cool the carbons to a temperature below that at which rekindling can take place.

The periodic curves show that the tension necessary to assure these two conditions depends on numerous factors: The nature of the carbons, quantity of the current, length of the arc, frequency of alternations, and constitution of the exterior circuit. The author has directly investigated the effect of these diverse elements in determining the disposable E. M. F. (that is to say, the E. M. F. induced by the machine, which must not be confounded with tension at the terminals) strictly sufficient for maintaining an arc, sheltered from exceptional currents of air. He will recall here some results which have already been published, completing them in several details.

Firstly, experience has shown that the voltage increases very rapidly with the length of the arc. This conclusion, being almost obvious, will not be referred to again. Finally there is ground for distinguishing the case of homogeneous carbons from that of wick carbons.

First. Homogeneous Carbons.—One can easily enough form an arc of 30 to 40 amperes with homogeneous carbons by the use of an induced E. M. F. of 40 to 45 volts. When we reduce the quantity to ten amperes, one is tempted to diminish the E. M. F. of the machine, but immediately the arc goes out; if we then try to maintain the same E. M. F., but add to the circuit a resistance or a self-induction, the arc still goes out.

Finally, the only satisfactory solution is to increase the E. M. F. at the same time that resistance or self-induction is inserted in the circuit. This increase ought to be, with the sort of carbons under discussion, as much greater as the quantity of current is lower; it depends to a great extent on the quality of the carbons, the most friable being those which give most steadiness. The carbons of the Jablochhoff candle have exceptional qualities in this respect.

Finally it is necessary to reduce the diameter of the carbons proportionately to the quantity of current, and to produce the smallest arcs, it has been absolutely necessary to resort to the carbons of the Jablochhoff candle, which are constructed for very high current densities.

The following table shows some of the results obtained :

Efficient Quantity of Current in Amperes.	Quality of Carbon.	Diameter in Millimetres.	Length of Arc in Millimetres.	Minimum Efficient E. M. F. in Volts.	Tension at the Arc Terminals in Volts.
37	C homogeneous, hard	10	2	44.5	32.7
14	C " "	10	3	56	40
8	C hard	5	2	68	50
6	Jablochhoff	3	3	72	50
5	"	3	$3\frac{1}{2}$	40	30
4.6	"	3	3	54	37
20	Retort Carbon, trimmed.	6	$3\frac{1}{2}$	76	45

It was practically impossible to go lower than four amperes with the voltage available.

The necessity for employing at the same time a high induced E. M. F. and a resistance or self-induction is easily explained when we recall the fact that the flow of electricity takes place at each instant of time, not by virtue of the E. M. F. itself, but because of the difference between that E. M. F., \mathcal{E} , and the constant tension u , necessary for the vaporization of the carbon; we may then by calling ρ the resistance of the arc itself, v that of the

remainder of the circuit, and l the self-induction, write the equation of the current under the form

$$(\mathcal{E} - v) - (v + \rho) i - l \frac{di}{dt} = 0.$$

But as we know from results relating to the continuous current arc, ρ varies perceptibly enough in inverse ratio from i ; i would then be indeterminate if there were no limits to v or to l .

Besides the tension of rekindling being much higher than the normal tension u , $\mathcal{E} - u$ must necessarily be great; however, to have i small, it is necessary that v or l may be large enough.*

Whether using either homogeneous or wick carbons, whenever there is reason or necessity for employing rheostats or bobbins in the circuit, experiment as well as reasoning lead us to prefer the employment of self-induction to that of resistance, because it carries in its train no loss of energy; and because on the other hand it shortens the extinctions owing to the special form which it gives to the curves of tension. We may say that self-induction gives a peculiar elasticity to the circuit, and this is measured by the difference between the efficient disposable e. m. f. at the lamp terminals on open circuit, and the efficient tension between the points of the carbons while the current is passing.

In general this elasticity may be produced by other inductive phenomena, such as the reaction of the armatures of machines, the mutual induction of the circuits of transformers, etc.

Let us suppose, for example, that an arc be placed in the secondary of a transformer whose primary circuit is fed with a constant potential E by an alternator. Generally the tension at

* Dr. Hopkinson has made the integration of the problem (*Journal of the Society of Telegraph Engineers*, vol. xiii., 1884-85, pp. 495-515) admitting for the differential equation the form:

$$E_0 \sin \frac{2\pi t}{T} + A - v i - l \frac{di}{dt} = 0,$$

in which all the coefficients are constant. He has also implicitly admitted the existence of a counter-electromotive force acting even during the extinctions; the solution also gives, contrary to experience, a divergence between the quantity and the tension.

The same applies to the differential equation

$$L \frac{dI}{dt} + RI + \frac{1}{c} \int I dt = E_0 \sin 2\pi \frac{t}{T},$$

proposed by Messrs. Mascart and Joubert in the hypothesis of a polarization of the positive electrode.

In reality the problem seems not to be susceptible of a mathematical interpretation, because the term e appears only at the beginning of the kindling of the arc; and because it is impossible on the other hand to bring into the equation the phenomenon of the disruptive discharge.

the terminals of the primary E_1 will be notably inferior to the induced e. m. f. of the alternator E , (the latter e. m. f. to be measured at the terminals of the alternator on open circuit). If then at a given moment all the lamps be extinguished without changing the excitation, the tension at the terminals of the primary will lose a value $E_1' > E_1$ and the e. m. f. induced by the secondary will become $E_2' > E_2$.

The difference $E_2' - E_2$ measures the elasticity of the arc circuit and is not generally negligible; it is to be noticed that it increases with the charge of the alternator, especially if the latter be of iron, for which the difference $\mathcal{E} - E_1'$ is usually very important. The stability will increase at the same time.

This hidden effect may explain why the same lamps work well at certain times and not at others.

Second. Wick Carbons.—Steadiness is obtained the more easily as the wick is softer. So there is seldom any comparison possible between wick carbons and hard carbons. I will quote as an example the following experiment made with a La Cour alternator, giving 80 volts induced e. m. f. and 45 volts at the terminals when closed on a lamp of 50 amperes; wick carbons of an increasing degree of conductivity were successively placed in the lamp, and the arc was allowed to lengthen until extinction took place. The length of arc that may be taken as the limit of stability has varied from 3 mm. (hard homogeneous carbons) to 32 mm. (soft low-voltage wick carbons).

Under these conditions it is difficult to give definite figures relative to wick carbons. The author will only remark that the arcs corresponding to the curves reproduced here were obtained with e. m. f. superior to 45 volts. With very low voltage carbons the author has been able to reduce the induced e. m. f. necessary for stability to 40 volts, with arcs of 8 amperes presenting tensions comprised between 24 and 30 volts, and one might go even lower by using wicks of great conductivity, as has been done in certain cases, especially in Germany. Adopting this way of thinking, the establishment of Gruz & Co. has published recently a description of the following process of distribution: The current should be furnished at a constant potential by transformers giving 100 volts at the terminals of utilization; three derivations of 33 ohms each taken from the secondary circuit feed the lamps in shunt. Notwithstanding the elasticity which the primary circuit is able to furnish

to the secondary, as we shall soon see, these conditions exact the use of exceedingly soft wick carbons and even then perfect stability is not assured. It seems more advantageous to set up the three lamps in series, as will be seen later, or to count at least on 45 volts of induced E. M. F. for each arc in simple shunt.

The part played by the frequency is double; on one hand, increasing the alternations increases the self-induction; and on the other it diminishes the absolute duration of the extinction.

It is then probable that a rapid periodicity is very favorable to stability; the author has compared, with this in mind, arcs of 26 and of 52 periods, maintaining in both cases 70 volts E. M. F. and a self-induction of 0.0064; with carbons of 10 millimetres not less than 15 amperes could be used in the first case, and 10 in the second. This is only, be it understood, a general indication, as the 26 period arc dazzles too much. Further, one cannot go below 40 periods on account of the flickering of the light.

III. PRACTICAL APPLICATIONS.

Owing to the method followed in carrying out these experiments, that is, with a clearly defined construction of the circuit, it is easy to apply the results obtained to ordinary practical cases.

Let us suppose that it is a question of direct distribution in series, comprising a circuit of n arcs, with a *total* resistance R outside the arcs, and a *total* self-induction L ; let \mathcal{E} be the induced E. M. F., on open circuit, of the alternator which furnishes the current. In practice one can consider each arc as an isolated arc fed by a circuit having resistance $\frac{R}{n}$, self-induction $\frac{L}{n}$ acted

on by an E. M. F. $\frac{\mathcal{E}}{n}$.

On the contrary, if it is a question of distribution in derivation, each arc may be considered as fed by a circuit having resistance nR , a self-induction nL , in which is acting the E. M. F. \mathcal{E} itself in the case of direct distribution; or the E. M. F. divided by the coefficient of transformation in the case of a distribution by transformers.

We can then foresee approximately what type of curves we shall have occasion for in each case. Circuits in practice nearly always possess a considerable self-induction; the periodic curves will then most usually be those which have been given for inductive circuits. Iron contained in the machine or in transformers

may also produce a certain effect, more difficult to foresee, on the form of the curves or quantity, as was noticed above.

This admitted, two questions should be examined from the point of view of industrial practice: The steadiness of the arcs; and the economy of the system of distribution.

Definite *stability*, as we have just seen, is the same for an arc in simple derivation as for the equivalent isolated arc. But if we group several arcs in series, their individual stability increases rapidly with the number of lamps, and the same is true of continuous current arcs. That is true, very probably, for the reason that the elasticity necessary to each one is furnished by the total resistance of the circuit. In other words, if one of them tends to go out, it would be seldom that all should have the same tendency at the same time; therefore, each one of them profits for its own account, by the whole of the disposable E. M. F. (the difference between the induced E. M. F. on open circuit and the sum of the tensions between the electrodes of all the arcs combined.) Moreover series distributions by the machines of Gramme, (Jablochhoff candles), Westinghouse, etc., show an excellent stability.

By reason of this fact, long ago demonstrated, and to the rather low voltage necessary for an alternating arc, lighting by alternating currents from transformers in parallel, is carried on nearly everywhere to-day, using transformers of 100, 110 or 120 volts, on which the lamps are grouped in derivation, with three or four in a series.

This process, favored by the houses of Ganz, of Buda-Pesth, and Helios, of Cologne, is rapidly coming into general use. The Helios plan is to use at a frequency of 40 periods (Zipernowsky apparatus) four arcs on transformers of 110 volts, which amounts to 27.5 per lamp; they attribute the success of this disposition to a peculiar make of lamps. In reality the latter do not possess any mysterious virtue, and the stability obtained with such low voltages ought rather to be attributed to the grouping in series, and to the exceedingly high conductivity of the wicks of the carbons. This quality of the wick seems to be magnified by the motives which will be pointed out later on; the author does not believe that so great a reduction of the voltage is an advantage.

But the grouping in series is nevertheless commendable; with suitable carbons it is easy to place three lamps on the circuit at 110 volts, adding, if desired, a self-induction bobbin to increase

the stability. The want of success recently experienced in Paris, with alternating current lamps, should be attributed, for the greater part, to an insufficient knowledge of the conditions necessary for the stability of the alternating arc.

To *economically* distribute light by alternating current arcs, the three following desiderata must be satisfied: First, to reduce the loss from the Joule effect in the carbons by giving them the highest possible conductivity; second, to reduce the loss in the lamps, the conductors and the machines, by augmenting as much as possible the factors of power of the circuit and of the arc;* Third, to augment as much as possible the yield in luminosity of the arc itself.

The first condition is easily filled by the employment of a dense paste of high conductivity for the homogeneous portion of the carbon, the section occupied by the wick being relatively insignificant.

The second requires the adoption of a soft wick of which the result is as has been seen, a reduction in the self-induction or the rheostat necessary to secure stability, and the assimilation of the arc itself to a simple non-inductive resistance.

The third leads unfortunately to contrary results. The employment of self-induction is indeed very advantageous in reducing the extinctions and the lowering of the degree of incandescence which is the result of them. On the other hand the use of soft wicks noticeably lessens (at least 15 to 20 per cent.) the brilliancy of the incandescent portions, and thus imparts to many alternating arcs, especially to those of small quantity, that reddish tint, which may be easily verified. In reality, soft low-voltage carbons, present a phenomenon intermediate between that of the arc properly so-called, and that of simple incandescence; analogous to that of the Reynier, Werdermann and other lamps, known as "semi-incandescent." The luminosity obtained under these conditions is inferior to that given by high-voltage carbons.

To realize economical lighting, we should endeavor to compromise in the greatest possible measure between these two opposite

*This does not refer to the factor of power of the alternator itself (ratio of the tension at the terminals of the induced E. M. F.) because that is constantly variable with the charge, and necessarily must have a very small value in iron machines. The author has recently shown elsewhere (*Lumière Electrique*, vol. 46, 1892) that to realize the maximum of utilization in any given inductive field, the factor of power must be reduced to $\frac{1}{\sqrt{2}}$, as is the case in many iron alternators.

points of view ; and this can only be done in a rational manner, when a series of photometric measurements shall allow us to calculate exactly the luminosity given as a function of the voltage demanded by wick carbons.

Meanwhile, constructors seem to neglect a little too much, the question of luminosity, in favor of the questions of stability and convenience, and it would be well to resist an excessive lowering of voltage, informing consumers that if they feed with the same current and the same number of watts four lamps in series in place of three, it is at the expense of the quantity of light furnished by each one, and may even be at the expense of the product of the whole.

The author considers as provisionally to be recommended the grouping of lamps in series of three on transformers of 110 to 120 volts, with carbons of medium voltage (32 to 35 volts at the extremities of the carbons), the remainder of the tension being absorbed by the regulating bobbins of the differential lamps, or by a self-induction bobbin added in series ; we shall have thus a satisfactory stability without sacrificing the luminosity by reducing the factor of power too much.

IV. SUMMARY AND CONCLUSIONS.

In summing up this enquiry we are led to several conclusions ; the chief of which are the following :

1st. The phenomena of the alternating current arc are more complex than is ordinarily supposed, and cannot be brought under the head of a single type. The differences in the effect of machines for feeding the arc may, nevertheless, be explained for the most part, according to the value of their constants (resistance and self-induction).

2nd. The form of the periodic curves depend both on the composition of the circuit, real or fictitious, and on the quality of the carbons as well as their wicks ; the latter play an extremely important part in all respects. The extinction of the arc which happens at each alternation, is not always accompanied by a cessation of current ; this cessation of current disappears as much more easily as the circuit is more inductive and the wick a better conductor. It is very long, on the contrary, in hissing arcs on a non-inductive circuit.

3rd. To interpret the results obtained, we must bring in not only the vaporization of the carbon, but also the effects of forcible

molecular detachment and the conductivity of the heated gases and the products of the wick. There seems to be in the arc no counter electromotive force in the true sense of the word.

4th. The factor of power applicable to the arc approaches the nearer to unity in proportion as its operation is silent and the wick soft. With low voltage wicks, it easily reaches and passes 0.95, and the arc may then be compared to a dead resistance, whilst with homogeneous carbons and especially with the arc crying or hissing, the factor may fall as low as 0.70 with frequencies of 26 and 52 periods.

5th. The stability (steadiness) of the arc depends both on the quality of the carbons and their wicks and the disposable electromotive force; which must not be confounded with the tension at the terminals; it increases with the frequency and is favored by self-induction.

6th. The use of arcs in series is recommended in all respects, but it should not necessarily involve the use of low voltages; because wicks of high conductivity transform the alternating arc into a sort of semi-incandescent lamp whose stability and factor of power are excellent, but whose yield in luminosity seems mediocre. The study of the latter point demands special researches.

ON THE CONTINUOUS CURRENT ARC AND ITS
EMPLOYMENT AS A PHOTOMETRIC
STANDARD.

BY A. BLONDEL,

Engineer, Dep't of Roads and Bridges, Paris.

Object of this Enquiry.—Much discussion has arisen, especially of late, on the nature of the continuous current arc. One of the phenomena which have most attracted attention is the production of light on the positive crater, and the important fall of voltage correlatively produced on that surface of passage.

The constancy of the intrinsic brightness (luminous intensity radiated per unit of surface) had been previously announced as very probable by M. Rossetti* ; and in a more recent note Mr. Silvanus P. Thompson† had affirmed it as the result of certain unpublished experiments made by Captain Abney, explaining it by the ebullition of the carbon.

Finally, more than a year ago, during a discussion at the Institution of Electrical Engineers of London,‡ Mr. Swinburne had expressed the idea that by placing a screen pierced by a pin-hole in front of the crater, one could make an absolute standard of light, a process which has perhaps been already applied by Captain Abney for a different purpose ; Mr. Silvanus P. Thompson also made some remarks to the same effect. But no effect being given by the authors themselves to these proposals, they were condemned afterward by Mr. Trotter in default of experimental

**Rendi Conti dell' Accademia die Lincei* (1878-79).

†*Society of Arts*, March 6, 1889.

‡June, 1892, p. 381 and 408.

proofs. The echo of them had not reached France, when M. Violle* undertook, on the brightness of the arc, a series of measurements more complete and more precise than all those of his predecessors, and from whose results I present an apparatus capable of being employed as a secondary standard of light.

The experiments of M. Violle were executed by two different methods: the spectrophotometer, and photography.†

The learned professor found that the brightness of the positive carbon is independent of the electrical power expended, (quantity and voltage). But it was not proved to be independent of the quality of the carbon. To clear up this point, I made, in collaboration with M. Le Chatelier, measurements of carbons of different origin. The instrument used, the pyrophotometer, having failed to indicate any difference, we believed ourselves obliged to conclude, while reserving the right to make more precise experiments, that the nature of the carbon had no sensible influence.

It is following these conclusions that I have constructed and presented to the Society of Electricians on March 1st, 1893, the instrument for which I have suggested the name of "*arc etalon*," (or, arc-standard of light), and which realized for the first time in a practical manner the employment of the crater as a standard.

Recent experiments, carried out as will be seen further on, have manifested the variations which escaped the pyrophotometer by reason of the feeble sensitiveness of that instrument; but they have not modified my conclusions on the subject of the usefulness and legitimacy of the use of the arc-standard as the secondary standard for the photometry of arc lamps.

I propose to show here the motives which urged the adoption (or at the least the trial of this system), the mode of employment, and the possible precision.

Unit and Standards of Light. It is an error to believe, as is sometimes said, that the unit of light can be defined in an absolute manner, as a function of the ordinary physical elements, and brought in consequence under the c. g. s. system.

* *Bulletin of the International Society of Electricians*, June, 1893.

† The first of these methods only, seems able to inspire perfect confidence, for one can photograph the crater only through and across the arc, in which it disappears; and the latter, although transparent and barely luminous, has a considerable actinic power compared with that of the crater itself, and capable in consequence of alternating in a great degree the photogenic differences of the brightness. For my own part, even in employing the very short exposures which are indispensable, I have never been able to obtain in the photographs the effect of the crater alone, independent of that of the arc.

Light, considered from the photometric point of view, that is to say, such as we need to measure for practical application, is not a physical quantity, but really a physiological quantity, irreducible into other quantities considered by physicists.

The unit of light can, therefore, never be defined otherwise than by a concrete standard, and the *sole instrument of measurement* applicable to photometric determinations, will always be the normally constituted human eye.

In consequence of the researches of M. Violle, the International Commission of 1883, adopted as the absolute standard, the standard which bears his name and which fills all the desired conditions of unchangeability. There is no cause to lay blame on the latter if the small Siemens platina standards constructed to reproduce it have not been successful; neither to go into the

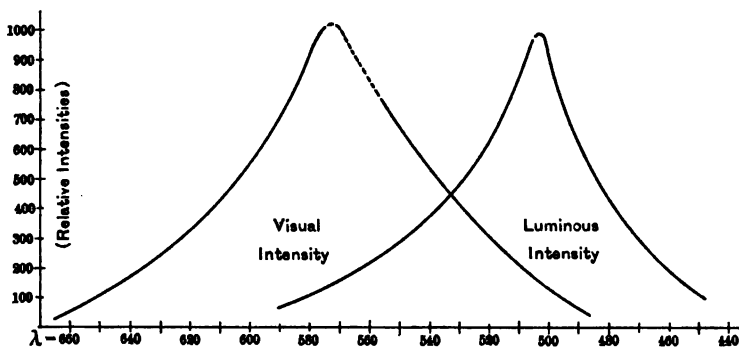

FIG. 1.

question of the adoption of an absolute standard; again, all measurements ought to be expressed in decimal candles.

Each country and each laboratory, is evidently free to employ by preference such or such a lamp as a secondary standard, but on the condition that the figures obtained be transformed into decimal candles,* in place of taking, as is done too often, the secondary standard as the unit.

Inadequacy of Present Methods and Standards for the Photometry of Arc Lamps—But the Violle standard, and the second-

* The use of the Carcel is nevertheless useful in cases having to do with excessive intensities like those of light-houses. In the French light-houses, to avoid excessively high figures, we express the measurements in Carcels of 10 decimal candles. Furthermore, the question is under discussion to adopt a higher unit of the value of 1,000 decimal candles, and to call it by a special name, *kilobougie*, or *pyre*.

ary standards at present in use, are well adapted only to the measurement of sources having nearly the same tint. As soon as we undertake the photometry of arc lamps we run foul of both theoretial and practical difficulties.

Admitting even that one may overcome the practical difficulty of equalizing two sensations so different as those produced by the two plates of the photometer, it remains none the less theoretically impossible to express by a single figure the ratio of the intensities of two sources of different composition.

This theoretical impossibility which (*à priori*) renders illusory the methods heretofore known, and all of those which may have been proposed later, arose, as is known, from three principal causes, all having a physiological origin.*

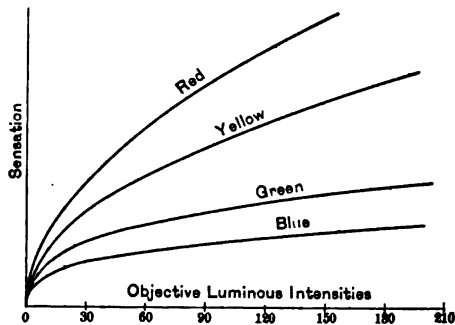

FIG. 2.

First. A light practically interests us at once by its luminous intensity and its visual intensity; that is to say, by the facility with which it enables us to distinguish details.

But, as has been demonstrated by numerous *savants*, particularly Dr. Charpentier, Messrs. Macé de Lépinay and Nierti and Prof. Langley, these two intensities do not vary proportionately between themselves in passing from one color to another, and the difference increases in proportion as the rays are more refrangible. Fig. 1, for example, reproduces the curves representing the distribution of the luminous intensity and the visual intensity in the spectrum, according to M. Charpentier.† The latter admits that vision comprises two distinct processes for the per-

* I leave aside the secondary causes, for example, those due to the yellow coloring of the "Jovea Centralis," and to the possible Daltonism of the observer.

† *Archives of Ophthalmology*, March—April, 1886.

ception of light; the distinction of details, and the perception of coloring. These results are confirmed, if not numerically, at least from a qualitative point of view, by Prof. Langley's experiments.

A comparison made between two lights not having the same spectral composition gives then different results, according to whether the luminous intensity or the visual intensity be measured.

Second. The experiments of the authors whom we have just cited, prove besides that the comparison of two hetero chromatic lights leads to different results, according to dimensions of the surfaces measured. These phenomena are too complex for me to analyze here; * furthermore, they have been partly made known through M. Weber's celebrated experiment.

Third. The intensity of the luminous sensation varies as a function of the absolute luminous intensity, following a different law for each color.†

I reproduce in Fig. 2, the curves of sensation traced experimentally by M. Charpentier for several of the colors of the spectrum. It will be seen that the sensations increase as much slower as the color is more refrangible.‡ This is the phenomenon of Purkingé; in visual as well as in luminous perception in successively measuring the absolute intensities necessary to produce the same luminous effect, and then the same visual effect as a monochromatic light chosen as a standard of comparison, § and whose impression is then taken as unity in the two systems of measurement. From this study they were able to formulate two very important laws:

(a.) The ratio between the visual and luminous impressions is independent of the objective intensity in the first half of the spectrum, and increases only slowly with the refrangibility.

(b.) Beyond the radiation, the proportion of the visual impression to the luminous impression increases very rapidly, and as much more rapidly as the objective intensity of the source is greater.

* See the works of Charpentier and of Macé de Lépinay.

† This statement is nearly the same as Helmholtz's.

‡ According to Helmholtz, Macé de Lépinay and Nicati, the curves intersect one another at a certain distance from the origin, which further exaggerated the phenomenon. But Helmholtz's curves are purely hypothetical; those of Messrs. Macé de Lépinay and Nicati rest on the law of Fechner, no longer admitted by anyone.

§ The source of comparison was the yellow portion of the solar spectrum under examination.

Fig. 3 represents the results obtained by Messrs. Macé de Lépinay and Nicati. From all of these physiological effects it results, without any ambiguity, that the definition of the intensity of an arc lamp as a function of the intensity of a yellow or reddish standard such as those actually in use, is, *a priori*, impossible*; and that hetero-chromatic photometric methods are illusory. They have for result only the effect of juggling away the material difficulty, in bringing the photometric measurement

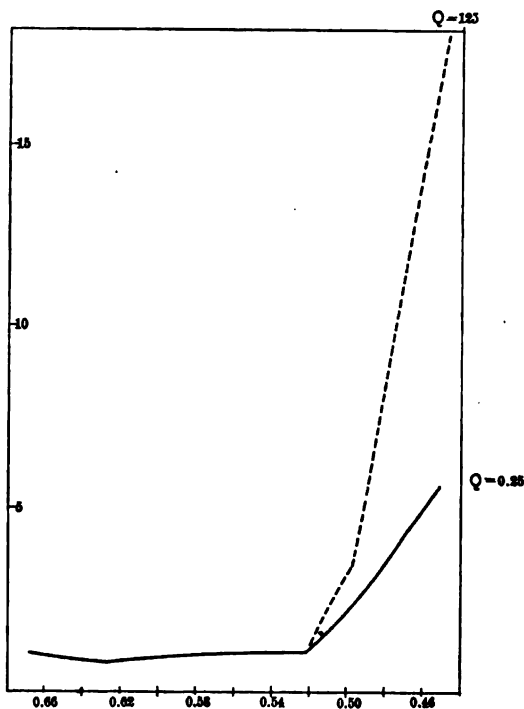

FIG. 3.

to one or two easy readings in mono-chromatic light. Once the readings are made or multiplied by a convenient coefficient, one obtains a figure representing the so-called intensity; the operator demanding nothing more, declares himself satisfied. But the theoretical difficulty has not been removed; it remains in its

*Helmholtz has said ("Physiological Optics," p. 420) that all effort to compare two sources of different colors is impossible. Nothing has happened to invalidate this high opinion, since the epoch at which it was enunciated.

entirety in the determination of the coefficient K^* . Besides, measurements of arcs obtained by several of these methods rarely agree. Generally speaking, the expression "an arc light of so many candles," has no definite meaning, for it does not indicate to what absolute value of illumination that measure refers, nor with what standard it is obtained.

The first reform to be made therefore, will be to insist that measurements be made always in identical, simple and clearly specified conditions.

If it is a question of measuring one isolated arc lamp, the following process seems capable of giving practical information.

1st. We compare the arc lamp with the standard, by the aid of a Foucault or Bunsen photometer, while winking the eyes, as described by M. Allard, until the sensation of color disappears. One obtains thus a value, characteristic of the luminous intensity, under conditions always identical.

2nd. We compare then the two sources by reading with them, aided by photometers based on the visual acuteness, taking care to give in all the trials the same value to the absolute illumination and to expressly indicate it; the most convenient is that which barely allows the reading the characters of ordinary print. One obtains thus a value of the visual intensity.

*To begin with, if this has been established by the method of equal visual impressions (for example, M. de Crova's method) it is inapplicable to the comparison of *luminous* intensities; it is the contrary if it is established by the method of equal luminous impressions (for example, M. Macé de Lépinay's method). It is always necessary, therefore, to specify the meaning of the coefficient K ; unless we employ two calculations, one for each of the two methods.

In the second place, let us see how this calculation has been made. In M. Crova's method ($K = 1$) he has estimated the visual intensities of the radiations in the spectra of the two sources, as a function of one of the radiations taken as unity; this is a very delicate operation and the figures found by the divers observers who have attempted it are, generally, little in accord. Once the curves of visual intensity obtained, we regard, according to Roof's law, the total impression of the spectrum as equal to the sum of the impressions of the radiations, then we bring the two impression totals to the same value by a change in the scale of one of the curves to determine the common ordinate. It is this reduction which does not appear to be legitimate, for in virtue of the Purkingé phenomenon, the relative impression of each radiation varies according to the absolute intensity.

In the method, not less ingenious, of M. Macé de Lépinay (*Comptes Rendus*, vol. 97, p. 428) he admits, as an experimental fact independent of Kirchhoff's theory, which applies only in the case of *dark* bodies (see *Le Chatelier, Société de Physique*, March 4, 1892, p. 134), that "bodies of the same temperature and of different radiating powers, placed in a dark situation, emit light of the same spectral composition, and that it suffices in consequence to measure two radiations to deduce from them the absolute intensity." But there again, to establish the coefficient K , we compare radiations of different tints without allowing for variations which the proportion undergoes by virtue of the Purkingé phenomenon. This coefficient does not then seem to be established in a legitimate manner. In an analogous manner one might find weak points in all of the methods of so-called hetero-chromatic photometry.

By the aid of these measurements,* both easily made without any intervention of colored screens, we determine the value of the light under the two extreme conditions of its use; that is to say those that are of the most practical interest. It is of small importance, in fact, that we should know exactly the value of a light when it is more abundant than necessary; the essential desideratum is to know what minimum of light it may furnish at the limit of possible utilization; once this is known, the effect of the Purkingé phenomenon causes less inconvenience than existing methods.

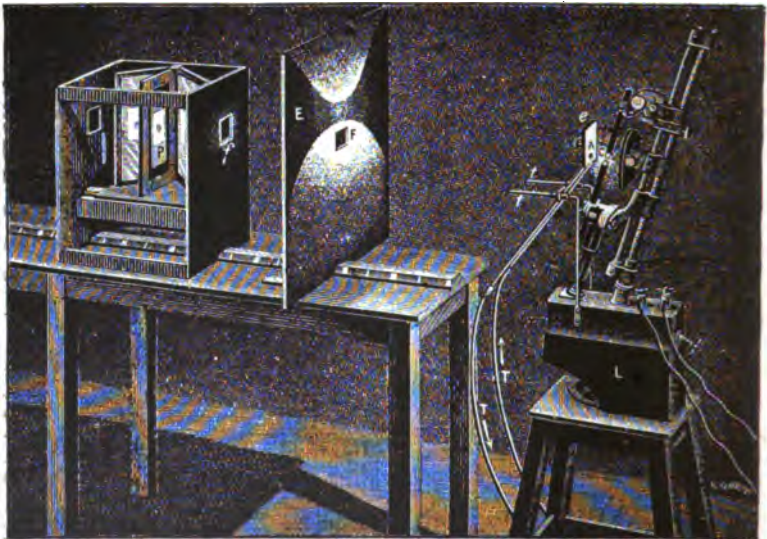

FIG. 4.—Plan of the photometric installation.

Nevertheless it appears to be much preferable to eliminate the causes of the difficulties noticed, by replacing for the study of arc lamps the standards commonly employed, by a secondary standard having also an arc for its origin, and having a nearly identical tint.† It suffices then to know once for all, the proper-

*It would be well also to make a measurement with a colored screen absorbing the blue and violet rays, so as to form an idea of the value of the lamp in foggy weather. It is known that the electric light loses then a great portion of its advantages.

†The tint of a lamp is always a little darker than the standard because the latter utilizes solely the most incandescent portion, but this difference is hardly noticeable and would not constitute an objection to this method.

ties of that standard to form an exact idea of the value of all lamps measured by it. This standard is obtained, as has been stated above, by isolating a small portion of the positive crater of a carbon sufficiently pure. The apparatus employed by me for this end answers very well in practice.

Description of the Arc-Standard Apparatus.—Figs. 4 and 5. The lamp employed by me and which adapts itself very well to this application, is a Sautté and Harlé projector lamp, whose carbons are both inclined about 20° from the vertical; thanks to this obliquity, the positive crater, situated on the upper carbon, presents a surface also inclined from 40° to 60° from the vertical, and which is easy to disengage completely from the lower carbon by giving the arc a length of 4 to 5 millimeters.*

Carbon being a nearly perfectly black body, the obliquity of

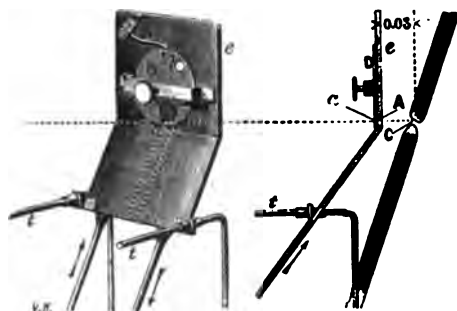

FIG. 5.—Details of the apparatus, seen in perspective and vertical section.

the incandescent surface and the proximity of a cold surface, cannot sensibly modify the law of emission. It would not be so if another substance were employed.

The opaque screen (Fig. 5)†, is formed by a little flat box bent in the middle, (and constantly cooled from within by a stream of water,‡ in the same manner as is the Violle standard,§ so as to prevent alteration in the shape of the metal), can change its position horizontally in front of the arc, for the length of two bars forming slides and fixed on the base of the lamp.

*One could also, but less conveniently, make use of a lamp with vertical carbons, with an oblique screen, adding a mirror to restore the pencil of rays to a horizontal direction. But it would then be necessary to take into consideration the co-efficient of reflection of the latter. Prof. S. P. Thompson has also proposed (*Philosophical Magazine*, July, 1893), to produce an oblique cut in a lamp with vertical carbons, by the aid of a magnet conveniently placed.

†Made by M. Werlein, optician, in Paris.

‡If the cooling by use of cold water be found troublesome, the metallic screen may be replaced by one of the same form, of refractory porcelain.

It is pierced at the height of the bend by a little conical hole, behind which can be rotated a diaphragm furnished with a certain number of openings of known dimensions. The dimension one millimeter seemed peculiarly appropriate for the study of arc lamps, for which it is usually an advantage to employ stronger standards than the ordinary. It gives then, as will be seen, an intensity of about 160 candles, which at four metres distance, produces on the photographic screen an illumination of about ten candle-metres very favorable to measurements. Besides it would be difficult to make a much smaller hole, because it would

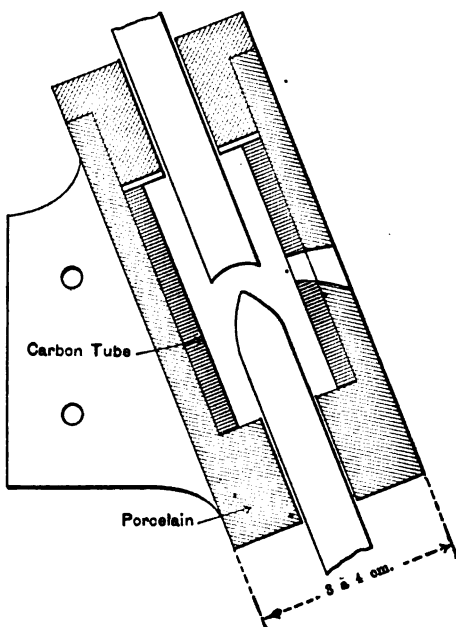

FIG. 6.

be too rapidly obstructed by deposits of carbon powder, and besides would give rise to troublesome effects of diffraction.

The hole in the diaphragm is placed at the height of the centre of the crater and at a very short distance from the latter (two to three centimeters). In this manner we obtain a luminous pencil, conical in form and very divergent, having for centre the little hole, and for its base the crater; its intensity in the horizontal direction is equal to the intrinsic brilliancy of the corresponding portion of the crater multiplied by the surface area of the open-

ing employed. This opening should be frequently inspected and cleaned to avoid errors which might arise from a reduction of its useful area by the deposits mentioned above.

The luminous source thus provided, and to which may be given the name arc-standard, may be used in the same manner as any photometric standard whatever; it is sufficient to place the lamp at one extremity of the bed-plate of the photometer, so that the opening in the diaphragm shall be at the same height as the centre of the screen of the photometer, which latter may be of any type whatsoever: Bunsen, Foucault, Mascart, etc.*

Care must be taken besides to completely enclose the lamp in a closed frame of blackened wood or sheet metal, with the double end of preventing draughts of air and excluding superfluous light.

The sole condition to be realized, but it is indispensable, is that the horizontal rays falling on the photometer shall proceed from the portion of maximum brilliancy of the crater, which alone gives a constant illumination.

To this end two sorts of precautions are taken:

First. We must secure a crater large enough, and very regularly, and if possible uniformly, illuminated. This result is attained by using a sufficient feeding voltage to assure a very high degree of stability, that is to say, at least 70 to 75 volts at the extreme terminals comprising the lamp and its rheostat; and beside this a density of current of at least 0.2 amperes per square millimeter.†

The purpose of this great density is to produce the maximum crater possible without hissing, so that it may be saturated with current, and consequently with light, while the arc cannot shift from one side to the other. The same result may be attained in another fashion, by making with the aid of a tube of porcelain biscuit containing a tube of carbon, a sort of small electric furnace, similar to that of M. Violle, placed astride of the two carbons, as shown in Fig. 6. Even in this case the density of

* Prof. S. P. Thompson has called attention recently to the error which may arise from the thickness and the eccentricity of the diaphragm. I do not believe that this influence is noticeable in my instruments, for the hole is cut bevelled, and the width of the streak is less than $\frac{1}{10}$ of a millimeter.

† The best results are obtained, for example, with carbons of 15 millimeters, 75 volts, 40 amperes and 5 millimeters length of arc; but one may be very well contented with carbons of 10 millimeters with 20 to 23 amperes, providing that they are of good quality. If the arc shifts and the crater is not uniformly brilliant, the conditions of the current supply or the type of carbons employed should be modified.

the current should be regulated so as to obtain a very uniformly white crater without hissing.

Second. The fact must be verified before each reading, that the light received by the photometer really comes from the most brilliant part of the crater; this operation is easily performed by placing behind the opening of the screen a small lens whose focal length has been chosen so that the crater may be at its focus. This lens, instead of being rigidly fixed to the diaphragm, may be more conveniently managed when placed at the end of a short lever, which may be raised or lowered without touching the diaphragm. The apparatus at the *Ecole Polytechnique* was thus constructed. We can thus obtain a very much enlarged and clearly defined image on a vertical screen, placed in front or in the rear of the photometer, and see in what part of the image the latter is operating.

The image of the positive carbon is projected under the form of a very bright elliptical surface whose length may reach several metres, and whose upper border is clearly defined on a black background. When the lamp operates well, this border is always illuminated to the maximum, and it is in this portion of the image that the photometer ought to be found. This adjustment is very easily made by placing the lamp in a convenient horizontal position, then raising or lowering the arc by means of a handle placed on the lamp for this purpose. As soon as this adjustment is complete, the lens is raised; we bring over the hole in the screen the opening with thin walls and of known surface, and the reading is made at the photometer.

The mean illumination produced on the latter is constant, but it presents sometimes around that mean small rapid vibrations due, it may be, to variations in the phenomenon of vaporization, or may be to the effect of the flame passing in front of the crater. The latter may be easily removed by a magnet; or, better, suppressed by maintaining the arc in shelter from the air, in the little furnace described above.

Experiments.—I have undertaken a series of experiments with the aim of comparing the brilliancy of different carbons, either directly with each other, or with the intensity of an ordinary standard.

In the first case I have opposed to one another on the bed-plate of the photometer two arc standards, similar to that described below, and of which one belonged to the *Ecole Poly-*

technique, having been especially constructed to facilitate this work.* In the second case I opposed simply an arc standard to a Carcel lamp on the bed-plate of the photometer, where I have measured it by the aid of a Mascart photometer with the petroleum standard.

This very simple method is the only one which inspires complete confidence, because it admits the direct study of the phenomenon, and besides possesses a greater sensitiveness than that of more complex instruments; it has admitted the demonstration of very important differences which were absolutely inappreciable by the pyrophotometer. Finally, by opposing the two arc-standards to one another, all those errors arising from difference of tint have been caused to disappear.

These experiments were made at the Central Laboratory with the co-operation of Messrs. Guilbert and Perrin. It was M. Perrin, Chief of *Travaux Pratiques* in the Laboratory, who willingly took charge of the labor of making the readings of the Bunsen photometer, which he handled with remarkable precision. Illness has prevented me from extending them as much as I should have wished.

The experiments were carried on with carbons of three different makers, which I shall designate by the letters *B*, *C*, *L*, being respectively homogeneous, soft or hard, and the others having wicks of varying conductivity.

Constancy of the Brightness of a Given Carbon under Constant Conditions of Current.—While employing carbons of poor quality, especially the very hard wickless sort, the brilliant portions of the crater are constantly shifting, and it is difficult to use the arc as a standard; on the contrary if we employ carbons of suitable quality, selected among different sorts, with the densities of currents which I have pointed out, we secure a high degree of homogeneity, and a great steadiness in the brightness of the crater. The latter, seen on the greatly magnified projection (about 100 times) given by the lens of the arc-standard, presents the aspect of a mass in ebullition, covered with little bubbles, forming and bursting uninterruptedly; but these bubbles are no longer perceptible when the lens is replaced by the opening with thin walls, and they are, besides, much too small in proportion to the photometric surface of a Bunsen screen to incommode the

* I desire to express here my gratitude to Messrs. Soutter and Harlé who lent me for these experiments two of their excellent projector lamps.

observer in any way, or to compromise the exactness of his measurements. In fact, with good carbons, the illumination of the photometric surface is remarkably constant and all comparisons have shown that this method of diaphragmation is perfectly legitimate in constituting a standard.

I give here by way of example a series of measurements made without special precautions, comparing the brightness of the crater of a ten millimeter carbon on 20 amperes of current with the intensity of one carcel.

Total length of the photometric bed-plate, 547.4 millimeters.
Distance from the carcel to the photometric screen :

Reading.	Average.
790	} 799
804	
790	
794	

which gives a relative error of less than two per cent. (If we refer to the figures of the table on page —, it will be seen that the relative error in the case where we employed two standards simultaneously, did not generally exceed four per cent., although the carbons tried were often badly adapted to these measurements). In general, therefore, one may expect to realize a precision within two to three per cent., which is sufficient for the measurement of arcs.

I will remark here that the bubbling aspect of the crater seems to bring a direct proof to the theory of the ebullition of the carbon.

Constancy of the Brightness of a Given Carbon under Variable Conditions of Current.—M. Violle having demonstrated that the brightness of a given carbon is independent of the conditions of current, and Captain Abney having reached a similar conclusion, I have not considered it necessary to take up that question again.* But I will remark here that the demonstration made by M. Violle applies only to the maximum brightness and to permanent condition of current. This may be easily verified by the two following facts :

1st. The average brightness of the incandescent portions, as a whole, such as we measure for example in light-houses, increases with the quantity of the current (see my recent memorandum on

*I have nevertheless ascertained that the intensity does not vary with changes in the current, as long as the arc does not hiss.

Electric Lighting of Lighthouses); it increases also with the density of the current up to the point of thorough saturation of the crater.

2nd. If we suddenly vary, by means of a rheostat for example, the quantity of current in a lamp, the intrinsic brightness suffers temporarily a very sensible variation, which may reach ten per cent., and which diminishes little by little until the shape of the crater is modified in a manner so as to bring the surface of emission to what it should be for the new value of the current.

This phenomenon is easily explained if we consider that the heating of the positive carbon is generated only at the surface of passage, and that in consequence the temperature of volatilization is only realized for a very thin superficial layer, which may momentarily attain a temperature greater than the normal value.

We may thus explain why it is that the points, blunted or even carved into little craters, in alternating current arcs of 25 amperes and over, present sensibly the same brightness as the crater of a continuous current arc; according to the measurements I have made with a pyrophotometer during a notable portion of each period, the arc remained thoroughly extinct, but during the remainder of the time the surface of passage presents a brightness much greater than the normal, because it is a little too small for the current.

Influence of the Quality of the Carbons.—This is the point on which I should the least dare to give definite conclusions on account of the complex character of the causes which may intervene.

In admitting that there may really be in the arc, vaporization of the carbon with a fixed temperature, it is further requisite, in order that the quality of the carbons shall be without influence on the brightness:

First. That they contain only a small quantity of foreign matter. This has not been the case hitherto, but to-day it is practically accomplished, thanks to the process of purification employed by the makers.

The greater part of light carbons contain not more than four per cent. of foreign matters, of which two per cent. are mineral salts. Here are, for example several analyses made by M. Le Chatelier in his Laboratory at the School of Mines.

	No. 1.	No. 2.	No. 3.
Carbon.....	93.00	95.10	95.50
Oxygen }	4.50	1.68	1.80
Ozone }			
Hydrogen.....	0.50	0.22	0.30
Ash.....	2.00	3.00	2.40

The oxygen and hydrogen are found nearly entirely in the form of hygrometric water.

Moreover, several of these bodies, as has been very justly remarked by M. Violle, are eliminated before the ebullition of the carbon.

Second. That the molecular condition of the body emitting the light shall always be the same. But at the temperature of ebullition the carbon no longer exists except in the state of graphite. The thin incandescent layer has therefore, perforce, always the same molecular condition, contrary to what takes place in the case of incandescent lamps which are at a much lower temperature. One may be easily assured of this by scratching the surface of the crater after it has cooled, proving that it is transformed into graphite for a small thickness. On this account, therefore, there seems to be no cause for variation.

However, experiments have established appreciable differences between different qualities of carbons of different makers, and some between those of the same make. There seems in that respect to be a small superiority in hard over soft carbons; here is an example :

Total distance between the two diaphragms ..		804 millimeters.	
Surfaces {	right-hand diaphragm.....	0.9038	“ square.
	left-hand “	0.8135	“ “

The carbon used for the right-hand arc, *L*, was a medium voltage wick carbon.

Carbon Used in the Left-hand Arc.	Distance from the Photometer		
	To the Right-hand Arc.		To the Left-hand Arc.
	Reading.	Average.	Average.
<i>L</i> soft.....	396.4	} 393.3	410.00
	393.7		
	394.2		
	393.3		
	392.2		
<i>L</i> hard.....	385.3	} 385.8	418.2
	382		
	390.7		
	385.2		
	387.8		
	384		

Other measurements of the same sort gave analogous results, which seem to indicate a small influence arising from the density or the friability of the material. However, these differences are trifling, compared with those offered by the physical properties of the carbons under consideration. These latter may indeed, according to M. Le Chatelier's experiments, be classified in two very different categories :

	Actual Density.	Calorific Power.
A.....	1.60.	7.94 calories.
B.....	2.	7.76 " "

It seems then, that there well may be, in all cases, vaporization of the carbon at the same temperature; the deviations declared hitherto being attributed either to experimental errors or to foreign substances, notwithstanding their small quantity. The following remarks will confirm this hypothesis :

Influence of the Wick.—The effect of the wick discloses itself, as is well known, by a lowering of the voltage, which is as much more important as the wick in mineral matters, silica, silicate, etc. During vaporization in the arc, these matters offer a more easy passage for the current, and their effect is felt on the crater in two ways; at first by a diminution in the extent of the surfaces raised to the maximum incandescence (which reduces the average brightness); and, further, by a reduction of this maximum brightness. This latter effect is very sensible in ex-

Carbons Used in the Left-hand Arc.	Distance from the Photometer Screen.		
	To the Right-hand Arc Standard.		To the Left-hand Arc Standard.
	Readings.	Average.	Average.
L homogeneous hard ...	276.6	} 279.6	267.8
	278.1		
	283.9		
	276.4		
C wick.....	263.6	} 264.2	283.2
	262.6		
	267.0		
	266.2		
	261.4		
L ₁ wick, high voltage...	275.4	} 276.1	271.1
	274.9		
	278.0		
L wick, low voltage....	265.0	} 263.6	283.8
	262.5		
	258.6		
	260.4		
	267.4		
	267.2		
263.9			

periments, as is shown in the following table of the results of a series.

Total distance of the two diaphragms.....	547.4	millimeters.
Surfaces of the openings in the diaphragms, left,	0.8185	“ square.
“ “ “ “ “ right	0.9088	“ “

Carbon used for the right-hand arc, *L*, with wick, medium voltage, very constant.

It will be seen that one ought to use wick carbons only with precaution. There are among them, however, some which give the best results for the arc-standard from the point of view of fixity. They should be selected by comparison with others of the same quality; the best are the soft carbons, or middling hard ones with a high voltage wick. The difference of brightness between a carbon and its wick ought not to be sensible to the naked eye on the photometer. It is of course implied that such a standard must be calibrated by comparison, and that one cannot *a priori* indicate is brightness.

Absolute Value of the Brightness.—I have determined this value by the results of more than fifty comparative measurements made by the aid of a standard-carcel and exclusively with homogeneous carbons of five different qualities. The average result obtained gave 158 candles, the extremes being 150 and 163.

The figures subsequently obtained with wick carbons fell to 130 (maximum brightness) and one could succeed in realizing even much lower values.

Case of the Hissing Arc.—I have demonstrated in a preceding memorandum* that the phenomenon of the hissing arc is distinguished from the ordinary arc, by a too intense and discontinuous vaporization, and that it is characterized by a change in the color of the arc. The latter, from violet becomes greenish, which indicates a lower degree of incandescence.† In combining these two remarks with the fact often stated, of a sudden lowering of the voltage at the moment when the arc begins to hiss,‡ I believe that it is possible to offer the true explanation of the phenomenon, and definitively put in accord the partisans of different theories of the arc. As long as the latter is hissing there is a

**Lumière Electrique*, January 13, 1892.

†This greenish tint has given rise, I think, to a false explanation of the hissing, by the presence of mineral salts.

‡For example, an arc of 20 amperes, 50 volts, beginning to hiss, changes abruptly to an arc of 28 amperes, 42 volts.

molecular detachment and tearing away, and the arc is a disruptive phenomenon conforming to Wiedemann's theory. When it becomes steady and silent, then vaporization takes the place of the molecular detachment.

Photometric observations give a confirmation of this view. In fact as soon as hissing begins, the arc loses its transparency and the brightness of the crater diminishes in a very marked manner; the difference reaches and exceeds ten per cent. Then when the hissing ceases, the arc resumes its transparency, one perceives the crater to be dotted with black spots indicating that the temperature had notably decreased. This disruptive phenomenon appears as soon as the density of the current exceeds a certain maximum, very near to that which I have indicated above as the proper condition of current to give to the arc standard. The disruptive tension necessary during the hissing is feebler in proportion as the carbons used are more friable.

This explanation of the hissing arc also assists in the interpretation of certain complex phenomena of the alternating current arc.

Conclusions.—In consequence of the variations still presented by the different carbons, and which will, perhaps, be eliminated later on by the use of chemically pure carbons, the arc cannot be actually employed as an independent standard; besides it would not be desirable on any account, for the Violle standard, chosen definitively, suffices for that task.

Its more modest function should be solely that of a secondary standard destined to furnish a rational and practical term of comparison for arc lamps. From this point of view no grave objection can be raised against its employment, for the mean error of readings with a given carbon of good quality does not exceed two per cent. Should it even be greater, it must still be considered as scarcely equivalent to those introduced daily without distrust by the employment of existing methods.

I hope that the Congress at Chicago will be so kind as to examine and take into consideration the two following propositions:

1st. There is necessity, (to the end of facilitating photometry of arc lamps, in giving the measurements a more easily compared basis than that of ordinary flames), for inducing electrical laboratories to employ, solely for this special purpose, a particular secondary standard called the *arc standard*, defined as the luminous intensity of a given surface of carbon at the temperature of

volatilization, and realized in the manner described above. In default of pure carbon the laboratory should employ a type of carbons always the same, at a high voltage and a quite steady illumination.

The mean value of this secondary standard will be established once for all, as a function of the Violle standard, under well defined conditions, that is to say, for a series of known independent values of illumination.

As to the measurements, they will always be expressed in decimal candles, adding the mention: *According to an arc standard.*

2nd. When we make measurements with an ordinary flame standard, we should operate preferably without colored screens, and indicate exactly the method under which the equalization has been accomplished, that is to say, the photometer and the standard employed as well as the absolute illumination at the moment of measurement.

ON THE SOURCE AND EFFECTS OF HARMONICS IN ALTERNATING CIRCUITS.

BY H. A. ROWLAND,
Professor, Johns Hopkins University, Baltimore, Md.

In all alternating current machinery, the current has been found in practice to depart from the sinusoidal form, and it is most important to determine the extent of this departure, its cause, and its effects on the transmission of power. It may be stated as a general rule, that the harmonics as well as the fundamental, are due to the electromotive force arising, either from the form of the poles of the dynamo, from change in the magnetic permeability either in the dynamo or transformers, or from other causes which we will discuss hereafter. The current caused, however, by the electromotive forces, will be found by dividing the electromotive forces by the impedances of the circuit, and thus in general, the effect on the impedances will be to blot out the higher harmonics, as the impedance is greater for the higher periods. In circuits used for electric lighting there will be, in general, very little trouble from these harmonics. When, however, we are driving a motor by a dynamo, there are two electromotive forces in the circuit working against each other, and if one of these electromotive forces contains the harmonics, and the other contains none, it is easily to be seen that the unbalanced part will contain a large proportion of the harmonics. This is likewise true of transformers used at high degrees of magnetization. Dynamos and motors will generally introduce harmonics in the armature circuit, unless the coefficient of mutual induction between the armature coils and field magnet coils is an exact sinusoidal function of the angular position of the armature. Likewise in the Tesla motor, the same principle of construction should

hold. This is accomplished by making the pole faces of a proper shape, and winding the armature in a suitable manner, so that the co-efficient of mutual induction shall be a sine function. In the case of transformers, however, it is best to limit the degree of magnetization, although the use of a low electrical frequency may allow a high degree of magnetization to be used without overheating. In the case of single-phase alternating current dynamos neglecting the change of the magnetic properties of the iron, the harmonics introduced by symmetrical pole pieces will be the third, fifth, seventh, etc., in the armature circuit. The same is true of the motor. A transformer in which, however, the iron is permanently magnetized in one direction, or a dynamo or motor with un-symmetrical pole pieces, might introduce even harmonics. This may also be caused by having a non-uniform magnetic density over the pole pieces. As remarked before, the harmonics in the current have their rise in the harmonics of the electromotive forces acting on the circuit, and the resultant currents generated by the electromotive forces, will be equal to those electromotive forces divided by the impedances. Now in a non-inductive load these impedances will be the same for all the harmonics, but in an inductive load the impedance will be greater for the higher harmonics. Consequently the effect of an inductive load is to blot out the harmonics.

Thus we often find for a badly constructed machine that the current curves are very nearly correct; that is, without harmonics. For this reason, self-induction in the circuit is often very useful. It is generally supposed that in the Tesla motor, the armature circuit should contain very little self-induction, but we have seen that self-induction plays a great part in eliminating the higher harmonics, and prevents considerable heating of the armature. The importance of the harmonics in practical work is very great, as they simply heat the wire, and waste energy without doing any useful work in the case of transmission of power by electricity. In lighting circuits, they are of less importance, as the object of installation is to produce heat only.

THE CHAIRMAN :—Has the Secretary any further business?

THE SECRETARY :—No sir, none at all.

THE CHAIRMAN :—Has any member of the Section any further business to present?

Mr. PREECE :—It is the custom in England where the work of a section of this kind is completed, to propose a vote of thanks to the chairman of that section, for the care and attention that he has devoted to the furtherance of the business of the section. And I am quite sure you will all coincide with me, when I say it would not be amiss to thank the Chairman for the constant attention and watchfulness with which he has conducted the business of this section. I, therefore, move that we extend a vote of thanks to the Chairman of this Section.

Thereupon the motion was put and unanimously carried.

THE CHAIRMAN :—I thank you for the appreciation which is shown by the applause and expressed in the remarks of Mr. Preece. The duties of the chairman have certainly been very simple, except when he has been obliged to contend with the locomotives on the outside. During such time he has been signally unsuccessful. I think, however, that I may apply your applause and Mr. Preece's remarks to the Secretary as well as to myself, for I know as no one else probably can know so well, how Lieut. Reber has devoted himself to the work in hand, and how little myself or other members of the committee could have done without his constant and devoted assistance.

I now declare this section dissolved.

SECTION C.

FIRST MEETING, TUESDAY, AUGUST 22, 1893.

The meeting was called to order at 10 A. M. by Prof. Edwin J. Houston, of Philadelphia, who stated that the first business in order was the election of permanent officers of the Section. The following committee was appointed to nominate permanent officers: W. J. Johnston, of New York, Chairman; Ralph W. Pope, Horatio A. Foster, Edward Caldwell and Townsend Wolcott.

This committee reported the following nominations: for permanent chairman of the section, Prof. E. J. Houston, of Philadelphia; for vice-chairman, George P. Low, of San Francisco; for secretary, Prof. E. P. Roberts of Cleveland, Ohio; for executive committee, George W. Blodgett, of Boston; Dr. F. A. C. Perrine, of Palo Alto, Cal., and Townsend Wolcott, of New York.

These gentlemen were unanimously elected to fill the offices named.

In assuming the position of permanent chairman of the section, Prof. Houston said;

PROF. HOUSTON:—Gentlemen, I assure you I appreciate the very high honor that you have conferred on me in electing me permanent chairman of Section C, the Section of Pure Practice. As you are aware, the Electrical Congress has been divided into a Chamber of Delegates, and a General Congress consisting of three sections; viz., Section A, Pure Theory; Section B, Theory and Practice; and Section C, Pure Practice.

I am somewhat unfortunate in not quite understanding the reasons for this division into Pure Theory, Theory and Practice, and Pure Practice. It probably has arisen from the fact that a great number of papers have been presented, and that it is, therefore, necessary to arrange them under separate classes. I think it rather unfortunate, however, that there should have been an attempt made to draw this sharp divisional line between Pure

Theory, Theory and Practice, and Pure Practice, for to my mind, such division is unwarranted.

Though I recognize the fact that a different domain is occupied by the student of pure science and the student who applies pure science to practical purposes yet it seems to me that so many of the advantages to be derived from a General Congress arise from different types of minds and different types of students coming together that so much comes from the attrition of mind against mind, and the interchange of ideas, that it seems to me, judging the question, perhaps, hastily, that it might have been better to have arranged the numerous papers proposed for discussion in the Congress under topics rather than under sections. The arrangement has been made, however, and we accept the division as it stands.

To my mind there is very little difference between successful experiment and correct theory; for physical theory must almost invariably be the offspring of the laboratory experiment. Hypothesis may be purely theoretical, but as soon as it reaches the dignity of theory, we have something that we should not fear to put into cold material and thus test its correctness.

There is such a thing as good practice and bad practice. There can be no doubt as to what section good practice should be placed. In Section C, let us hope that the practice will be entirely and thoroughly good and therefore pure, being as it is, based on good theory. The more closely Pure Theory and Pure Practice are wedded, the better for each, especially for Pure Theory.

If the distinction between Sections A, B and C is made because of any essential differences which necessarily separate them, I wish to record my objection to such separation. If, however, it be made simply as a matter of advisability, that is, of the advantage of grouping allied topics, then I think it may be a good one and I trust that it is.

Far be it from me to disparage the value of the fruits of Pure Theory. I recognize thoroughly the priceless advantages which the so-called practical man has derived from the speculations and studies of the so-called theoretical man. The only point I wish to add before I take my seat and formally open the session of this branch of the Congress, is that I regret to see a tendency still existing in the minds of some few to believe that there is a necessary distinction between theoretical science and practical science. Such distinction cannot exist if science be truly science. Theory and practice in my mind are wedded, let them therefore not be divorced.

Again thanking you for the very high honor you have conferred upon me in electing me as your permanent chairman, I will in a few moments call the Congress to its regular work.

I think, however, before we begin our regular work, since we have many distinguished gentlemen with us, we would like to hear a few words from them. I therefore call on our honored

Vice-Chairman, Mr. George P. Low, of San Francisco, to address the section.

MR. GEO. P. LOW :—Mr. Chairman and gentlemen of Section C: There are times when the heart is so full that utterance is difficult. I am sure that this is the condition in which I find myself at the present moment. I have come from our extreme Western border, first as an education, and second, to make the acquaintance of those of whom I have read, whose works I have studied, whom I have long held in the highest estimation and whose labors in the promotion of our chosen industry, of the science to which we are so devoted, will always be looked upon with profound reverence. To be honored as you have done this morning in naming me as your Vice-Chairman, I am sure is something that is most thoroughly appreciated.

I hardly know that much can be added to that which our worthy Chairman has said. We have, unfortunately, I think, drawn a line between theory and practice that is perhaps almost unwarranted. We may have for our delectation, for instance, a sumptuous dinner. We will have dishes served to us that are the perfection of the Epicurean art. They will please every palate, but they must be seasoned. They will have a seasoning of this form or a seasoning of that form. Can we not compare such a repast to the treat that will certainly be extended to us in this Congress? Should not this treat be seasoned with both theory and with practice? Can we accept a seasoning only of theory or only of practice? It appears to me not. I am sure that of the two each is equal, and in each we bring about a better and perfect end.

Gentlemen, again I thank you most heartily.

The Chairman then called on Mr. Joseph Wetzler of New York to address the Section.

MR. WETZLER :—Mr. Chairman: In looking over the organization of the Congress, it strikes me that in the section we have here the position taken by the organizers, if I may be allowed to say so, is somewhat anomalous. After all, the division of a body of thinkers and workers into those devoted to pure science and those of pure practice, I think, is very arbitrary. We are all working, and whether our work is in one direction or another, appears to me of very little consequence. Although we say that the man of science works purely for science's sake, it is scarcely ever that this work does not, sooner or later, develop into pure practice. Without pure practice I think pure science would not thrive very long, and on the other hand, without pure science, pure practice could not exist.

The Chairman then called on Prof. D. C. Jackson, of the University of Wisconsin, to speak.

PROF. JACKSON :—I wish to congratulate the section in its organization, and I am very glad that a Section of Pure Practice has been given a place in this Congress. I really think that the

intermediate section, the Section on Theory and Practice, has received more than its fair share of attention in this Congress and that we ought to transfer some of our friends from the intermediate section to the third section (applause), while there is no doubt that there is a wide field between Pure Theory and Pure Practice that many men are working in, and working in very advantageously, yet in this country the electrical engineering has been developed so thoroughly from the practical end, that I was in hopes that this third meeting would receive much more attention than it apparently is receiving in the programme, and I hope that something can be done to make it worthy of the country.

The Chairman then called on Dr. F. A. C. Perrine, of Leland Stanford Jr. University, to speak.

DR. PERRINE :—I feel very much as the last speaker did, that the middle section has taken a great many of the papers which really belong to Pure Practice; the majority, in fact, of the papers that are down here in Theory and Practice, belong to Pure Practice. I noticed that the last speaker was also a professor of electrical engineering, and we are men who are trained in pure theory; then, perhaps, take up pure practice, and now, in teaching electrical engineering, we believe that we belong to Pure Practice rather than to a combination of Theory and Practice or Pure Theory, because that combination of Theory and Practice is supposed to be practice which has no absolute application. I believe that we will have here theory as it is applied in every day work, and therefore I believe that we will be able to secure at least discussion here which will carry us along the line of Pure Practice by taking from the pure theory and applying it, and I hope that we will hold ourselves together here and not only call this a section of mechanics, but also the ultimate section of the Congress.

The Chairman then called for the first paper on the programme which was read as follows:

ROTARY MERCURIAL AIR PUMPS.

BY DR. F. SCHULZE-BERGE.

Of the different types of mercurial air pumps which have been devised so far, two have been introduced into practice on a large scale, viz.: the Geissler and the Sprengel pump. Both are represented in numerous modifications and have undergone manifold improvements in the course of time. They produce vacua of the highest grade, but compared with the mechanical piston pumps, both of them are under the disadvantage of working only very slowly, so that they do not appear fit for evacuating receivers of large volume.

On the other hand, even the most perfect of the mechanical air pumps are far behind the mercury pumps so far as the degree of the vacuum produced is concerned.

To combine the advantages of both systems, my brother, Hermann, and I have together constructed the rotary air pump described below, which allows the creation of extensive vacua of excellent quality in a very short space of time.

I. PRINCIPLE OF THE ROTARY AIR PUMP.

We have carried out the apparatus in a number of different forms, all of which are based on the same principle.

The pump vessel is formed by a curved tube returning into itself, which revolves in constant direction around a stationary axis of rotation. A mercury piston passing through the interior of the tube creates on the one hand the vacuum, and expels on the other hand the evacuated air, while the connections required of the pump vessel with the receiver and the atmosphere are effected by stopcocks or suitable valves.

Of the numerous modifications which may be given to the apparatus on this principle, some will be shortly explained in this report, whereupon a more detailed description will be given of the one which has proved to be the most serviceable for practical use.

II. RING-SHAPED STOPCOCK PUMP.

The play of the machine is particularly conspicuous in the stopcock pump, Figs. 1 and 2. The hollow ring *P* has a diameter of one meter, or somewhat more, and an inner width of some

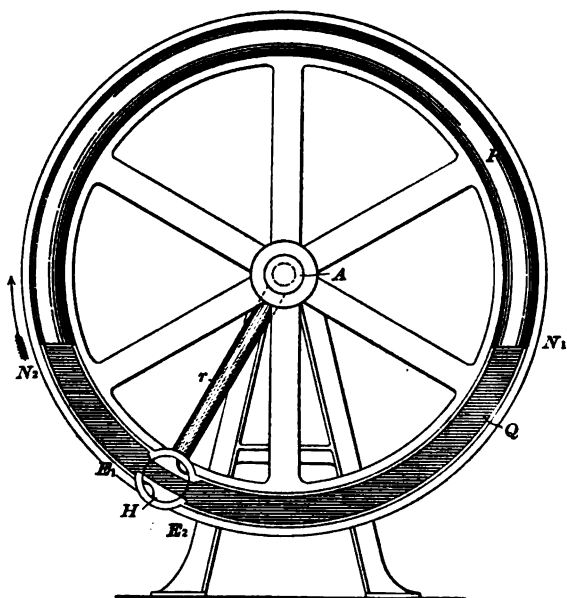

FIG. 1.

centimeters. It is revoluble around the horizontal axle *A*, which is hollow and closed at one end, while the other end is airtightly introduced through the stuffing box *s* into the stationary tube *R*. To the latter tube is connected the receiver to be evacuated.

Within the ring there is a quantity of mercury, *Q*, sufficient to equilibrate the pressure of the atmosphere if this pressure acts only upon one of the shanks of the mercury.

A three-way stopcock *H*, similar to the well-known Grassmann stopcock, is inserted into the circumference of the ring. The seat of the stopcock is connected to the hollow axle *A* by tube *r*.

The stopcock occupies three different positions during the rotation of the ring. In the first one it allows free passage to the mercury, as in Fig. 1. In a second one it prevents any communication between the parts of the ring r and tube r or the atmosphere. On the third position it connects the end E_1 of the ring with the atmosphere and the end E_2 with the tube r and the hollow axle A .

Let the ring be rotated in the direction of the arrow (Fig. 1) until all mercury has passed the cock, and let then the stopcock be given its second position separating the ring from tube r and

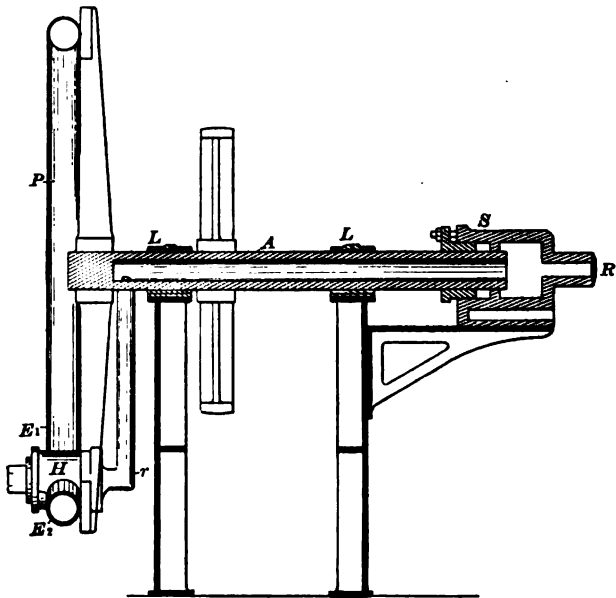

FIG. 2.

the atmosphere. If after this the rotation of the ring is continued, the mercury column will follow the upward motion of the stopcock until the difference of its levels corresponds to the atmospheric pressure. If then the stopcock is moved into its third position, air will rush into the ring from the receiver through the axle. The same occurs when the rotation of the ring proceeds, while at the same time the air above level n_1 is expelled to the atmosphere. When the stopcock reaches the mercury level n_1 , it is brought into its original position again, and the play of the pump is repeated similarly as described.

III. STOPCOCK PUMP WITH SPIRAL PUMP VESSEL.

In the apparatus just explained the mercury only partly fills the volume of the pump vessel *P* in which the vacuum is created, and only a moderate quantity of mercury is required.

A vacuum of very much larger volume may however be produced with the same quantity of mercury.

Suppose the pump vessel not to be formed of a single ring, as described above, but to have the shape of a double spiral, as in Fig. 3, the two ends of the spiral tube being joined by the stop-

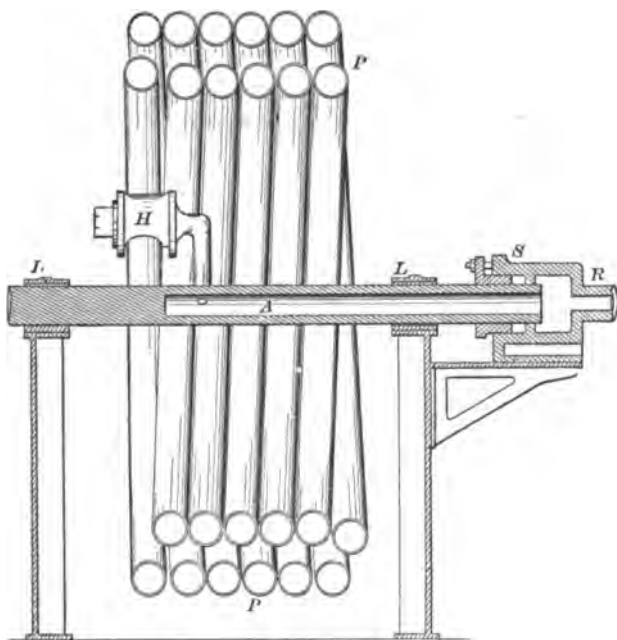

FIG. 3.

cock *H*. If then the spiral is supplied with the same quantity of mercury as the ring in Fig. 1, the whole volume of the spiral may be evacuated by a continued rotation. While the play of the machine is in all essential respects identical with the one of the apparatus Fig. 1, the vacuum produced may be given an extent arbitrary within wide limits without increasing the quantity of mercury required.

IV. RING-SHAPED VALVE PUMP.

The pump represented by Fig. 4 has, like Fig. 1, a ring-like pump vessel on a horizontal axle. The apparatus is sup-

posed to co-operate with an auxiliary pump (mechanical piston pump, water-jet air pump, etc.) in such a way, that the air exhausted from the receiver is not discharged by the ring into the atmosphere directly, but into a chamber in which a partial vacuum has been previously created by the auxiliary pump.

The place of the stopcock is here taken by the valve v , which is inserted into the circumference of the ring, and represents a spiral tube consisting of two convolutions. If the circumference of the ring be followed up in the direction of the hands of a

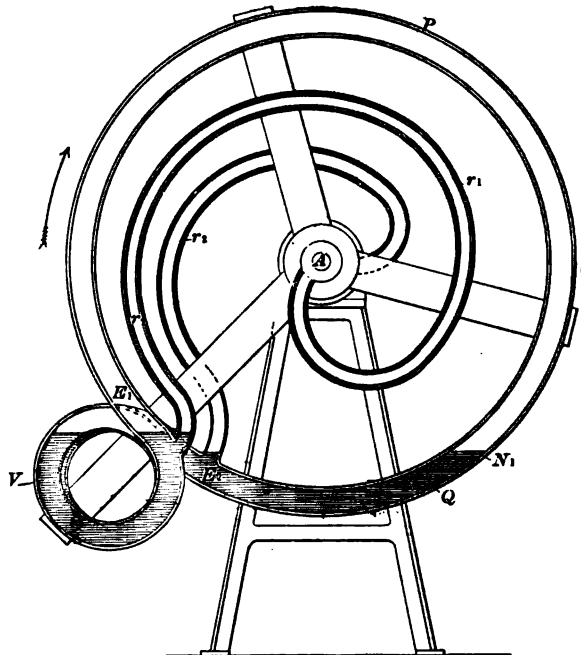

FIG. 4.

watch it will be noticed that the convolutions of the spiral run from E_2 in the opposite direction until they return at E_1 into the ring P .

The axle which in Fig. 4 is only shown in cross-section, projects as well in the front as in the back of the plane of the ring. It is hollow and divided into two compartments by a vertical diaphragm in its middle.

Each end of the axle is connected air-tightly through a stuffing box with a stationary tube in the same manner as the open end

of the axle Λ in Fig. 2 is connected to R . The one in front of the ring leads to the auxiliary air pump, while the tube on the opposite side is connected to the receiver.

At E_2 the tube r_2 branches off from ring P and communicates with the receiver through the axial compartment situated in the back of the plane of the ring, while another tube r_1 , starting from E_1 , is connected to the auxiliary pump through the other compartment of the axle.

The spiral valve and a part of the ring are filled with mercury.

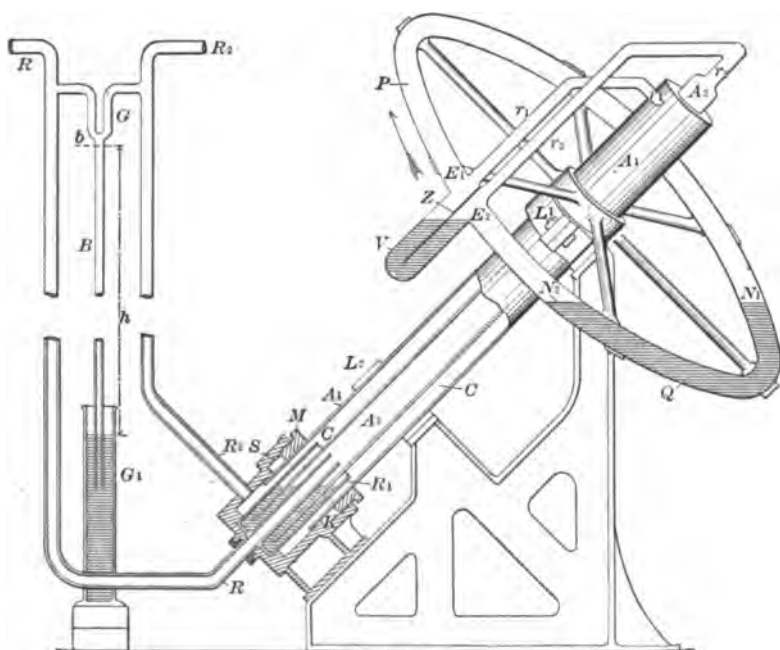

FIG. 5.

If the ring is rotated in the direction of the arrow, the air above level N_1 is expelled through r_1 into the preliminary vacuum, whence it is removed by the auxiliary air pump. At the same time air is drawn from the receiver through tube r_2 . This play is repeated at each revolution of the ring.

The vacuum in the receiver is permanently separated from the one existing in the auxiliary air pump by the mercury contained in the spiral tube, provided that in the latter vacuum the pressure be kept so low that the difference of pressure of both vacua

is equilibrated by the mercury of the valve. During every revolution a part of this mercury runs out into tube r_1 , but returns into the ring during the progress of the rotation. The width of r_1 therefore must be selected so great that the mercury running out of v never can fill the full cross-section of this tube.

V. DOUBLE RING PUMP.

The greatest difficulty met with in the production of high vacua by rotary air pumps is caused by the necessity of establishing an absolutely and permanently air-tight joint between the rotary and the stationary parts of the pump. Without doubt

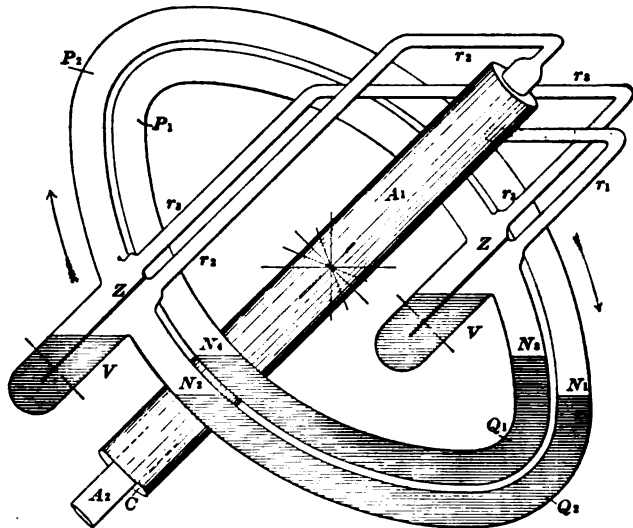

FIG. 6.

this is a principal reason why the practical development and application of rotary pumps has not been carried out so far. It is impossible to create and maintain a high vacuum according to the notions of this day without a connection warranting perfect air-tightness between the receiver and the rotary parts of the apparatus. If on the other hand the receiver were to be rigidly connected with the pump, it would have to participate in the rotation of the latter, which only in rare cases would be practical and recommendable.

While it is perfectly feasible to attain, in the pumps described above, the absolute airtightness of the axle required, still we did

not succeed so far in finding as simple a solution of the problem in those cases, as the one embodied in the description of the apparatus illustrated by Figs. 5 to 8. This pump is distinguished by its easy manipulation, quickness of work and reliability of action, and appears equally adapted for laboratory work as for industrial purposes.

Also this apparatus is supposed to cooperate with an auxiliary pump which is used to create a moderate preliminary vacuum.

To facilitate the general view of the instrument, only one of the two ring-shaped pump-vessels is shown in Fig. 5.

First the arrangement of the axle is to be considered. It con-

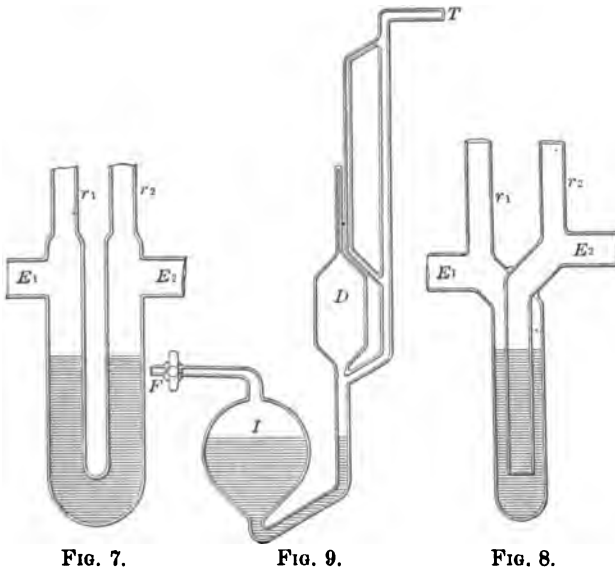

FIG. 7.

FIG. 9.

FIG. 8.

sists of the two concentric tubes A_1 and A_2 . The larger tube A_1 is mounted rotatably in the bearings L_1 and L_2 , has an inclination of 45° towards the horizon and projects with its lower end into the stationary stuffing box s . Through the bottom of s a tube R is introduced air-tightly. The same is surrounded by the wider tube R_1 as by a bell, the mouth of which is turned upwards. The intermediate space between R and R_1 is provided with mercury. Into this space dips the inner axial tube A_2 , which passes air-tightly through the closed upper end of tube A_1 and rotates simultaneously with this tube. The tube R is to be connected

with the receiver, tube R_2 with the auxiliary pump. These two tubes are connected by the forked tube G , which is so arranged that (after the vacuum is created) mercury may be introduced into the fork or withdrawn from the same by raising or lowering the vessel G_1 .

The ringlike pump vessel P is fastened to the axle by six radial arms and has an inclination of 45° towards the horizon. Into the circumference of the ring the valve V is inserted. It essentially consists of a cylindrical vessel closed at the bottom and parallel to the axle of rotation, which vessel is divided into two compartments by a tongue Z reaching nearly to the bottom of the valve. One of these compartments is connected to the middle tube A_2 of the axle by tube r_2 , while the second compartment communicates with the hollow space C contained between the walls of A_1 and A_2 . Instead of this shape of the valve we have used in different earlier apparatus a bent tube of the shape Fig. 7, as devised in 1885 by Clerc.* Also a valve of the shape Fig. 8 may be used advantageously in which the two compartments are arranged concentrically.

The valve V and about one-third of the circumference of the ring are filled with mercury, as illustrated by Fig. 5. If the ring is rotated in the direction of the arrow, the air contained above the mercury level N_1 is expelled through tube r_1 and the channel C to tube R_2 . At the same time air is drawn in the rear of level N_2 , through tubes r_2 , A_2 and R into the pump vessel.

Let the receiver now be connected to R , and the ring vessel be placed into the position shown in Fig. 5, so that tube r_1 may freely communicate with the interior of the ring.

First the auxiliary pump is worked and the interior of the receiver and of the ring pump evacuated to such a degree as the auxiliary pump may be able to produce, say for instance to 10 millimeters of mercury pressure.

During this time the mercury rises up in the barometric tube B , say to point b . Now vessel G_1 is raised so as to make the mercury enter the fork G , thus interrupting the communication between R and R_2 .

The level of the mercury contained between R and R_2 has not been changed by the preliminary evacuation, since so far the same pressure is acting within A_2 as in C .

*Clerc. Deutsches Reichs Patent 36,447.

If now the ring be rotated, air is drawn, by the action of the mercury piston explained above, from the receiver into the ring through R , A_2 and r_2 . On the other hand the air contained in the ring above N_1 , is expelled toward the auxiliary pump through r_1 , c and R_2 , while the mercury contained in v , permanently prevents a direct communication between the ends, E_1 and E_2 , of the ring.

The auxiliary pump is now only worked to the extent required for removing the air discharged from the ring, and to maintain in R_2 , and the parts connecting with this tube the pressure originally created therein.

With each revolution of the ring the pressure decreases in A_2 while between A_2 and A_1 it remains essentially constant. Therefore the level of the mercury contained between A_2 and R , will rise, while the level of the mercury between A_2 and R_1 must sink. The difference in the level thus produced cannot become greater than the one corresponding to the difference of pressure between the preliminary vacuum created by the auxiliary pump, and an absolute vacuum, *i.e.*, not greater than 10 millimeters in the present case.

Of course the difference of pressure between the preliminary and the final vacuum is also manifested in the shanks of fork g , thus permitting the observer to watch the progress of the evacuation until the increase of the difference in level becomes inappreciable. For further observation a McLeod's gauge is connected to R . We have used a modification of the same shown in Fig. 9. The end of the tube t connects with R . Raising and lowering the mercury in D is effected by corresponding increase and decrease of air pressure in I . For that purpose the tube F is connected by a rubber tube to the auxiliary pump. A drying tube inserted into the rubber tube keeps the air in I , free from moisture.

The stuffing box s , only serves to protect the *preliminary* vacuum against access of atmospheric pressure as far as required. This purpose is attained by a number of greased leather washers k inserted into the stuffing box which can be compressed by the nut-screw m .

The separation of the final vacuum from the preliminary one is effected by the mercury contained between r_1 and R and is accomplished thereby in a highly satisfactory manner. Even with the highest vacua attainable the seal proves absolutely reliable.

A seal based on the same principle may be used instead of the stuffing box *s*, to separate the preliminary vacuum from the atmosphere. We have carried out this arrangement in several apparatus. It requires a somewhat greater length of the axle, but does away with the necessity of paying attention to a stuffing box, as in Fig. 5.

The pump which we found to be the best amongst the various apparatus constructed, deviates from the one represented by Fig. 5, in one point only, which, however, is of great practical importance. Instead of a single pump vessel *P*, it contains two of them, viz., the concentric rings *P*₁ and *P*₂ (Fig. 6). They are so arranged that the air evacuated from the receiver during the rotation must pass through both rings in succession. First it enters through *r*₂ into the ring *P*₂ and is expelled (during the next revolution) by the piston *Q*₂ to *r*₃. Thus it enters the ring *P*₁ from which (during the following revolution) it is removed by piston *Q*₁ to *r*₁. Thence it is drawn off by the auxiliary pump in the same manner, as in Fig. 5.

The vacuum created in *P*₁ in the rear of *N*₁, improves with each revolution. The consequence is that, after the pump has been running for a short time, the air withdrawn from the receiver by ring *P*₂, is discharged into a space already highly evacuated, viz., into the vacuum of ring *P*₁. The whole volume of ring *P*₂, and the mercury contained therein will, therefore, come into contact only with air of high rarefaction, which circumstance is of great importance if extreme evacuation is aimed at.

The pump does not require any manipulation, except a simple rotation. It therefore can be easily run by machinery. For that purpose there is space provided on the axle for a pulley. For rotating the apparatus by hand wooden handles are used, forming prolongations of the six spokes of the frame.

By this pump vacua of so high a degree as to escape close measurements by the McLeod's gauge have often been created. For that purpose, of course it is necessary to provide for the absolute dryness of the mercury and of all parts of the pump and the receiver.

As drying material in producing high evacuation we have used metallic sodium with good success. It eagerly absorbs humidity and, while giving off hydrogen, is covered with a layer of caustic soda. As the latter is highly hygroscopic, it adds efficiently to the drying action of the metal.

The vessel containing the sodium was, as a rule, connected to the rest of the system by a tube susceptible of being closed by a mercury seal.

A pump of the kind described in which the outer ring had a diameter of 60 centimeters and a capacity of 0.9 liter, permitted 15 revolutions per minute when rotated by hand. At present a larger machine for industrial purposes is in course of construction, in which the volume of the outer ring amounts to 8.5 liter.

In conclusion I wish to remark that besides the apparatus described quite a number of different modifications of the pump have been worked out, every one having its peculiar merits or advantages.

I do not hesitate to say that although more than hundred years have elapsed since the construction of the first mercury pump, still I think that we are far from having fully realized the possibilities of perfection contained in this apparatus, and that we may expect valuable fruit from further work in this line, especially on account of the close connection of modern electrical research with the nature of high vacua.

At the conclusion of the reading of Mr. Shulze-Berge's paper, the Chairman stated that it was open for discussion.

DR. L. K. BÖHM, of New York:—The idea appears to be a novel one, and the theory to be correct, and, no doubt, the pump will work well. The simple spark gauge is a valuable instrument for measuring pressure and no vacuum could be produced which is not within the range of its sensitiveness.

MR. SHULZE-BERGE:—We have used different McLeod gauges, and the one in which the proportion between the bulb and the volume tube was the greatest had a ratio of thousand to one. Now, in those cases to which I referred, it was practically impossible to correctly ascertain the difference in height of the mercury levels of the gauge when the mercury was raised to the highest division of the volume tube. This difficulty always occurred when the pressure of the vacuum was in the neighborhood of 0.00000001 atmosphere (one hundred-millionth of one atmosphere). Now, it is stated that some higher measurements have been made, but I confess I do not see how it could be possibly done according to all the experiences that I have had with McLeod's gauges.

DR. BÖHM:—How do the cold-drawn steel tubes stand the high vacua?

MR. SHULZE-BERGE:—I have to remark first that the bigger form of the pump, which is intended for a lamp factory here, is built of cold-drawn steel tubing, and so in that case I do not

think there is any chance for any risk. The smaller pumps which were used, and which have served as models of the big one, were made of glass, and the glass had an inner diameter of one inch. In that case we have provided a device, which I have not described, because I did not want to go too much into detail, which is interposed in two places, on the one hand between the receiver and the tube κ , and on the other hand between the preliminary pump and the tube κ_2 . This device consists of a check valve and is so arranged that as soon as a break should occur in the receiver, wherever it may be, the check valve closes immediately and does not let in the air but very slowly. Thus, wherever the mercury may stand in the pump, it is only moved slowly and gradually. If that would not be the case, then the chances would be that the mercury thrown up suddenly here might possibly break this part. In fact, in some apparatus which we used in the first experimenting it has happened once, that the connection was broken by the mercury being thrown there, but with these check-valves there is no danger at all of this.

DR. F. A. C. PERRINE, of Leland Stanford Jr. University:—A discussion on this pump seems to belong in Section A, Pure Theory, as very few have an experience with anything similar. In regard to the question of whether the mercury would become dirty in this air pump, I suppose that perhaps it would be kept clean by the action of the preliminary vacuum, thereby taking up the action of air. But, I know that in the Geissler pumps, which are manipulated by preliminary vacua, there is a discoloration of the mercury unless the pumps are so arranged as to expel a slight portion of the mercury at each stroke of the pump, I do not see that there is any provision for expelling any of it except in Fig. 4; I mean, that there is any provision for expelling any mercury, and even in that, as I understand Mr. Schulze-Berge, the mercury runs back again. But, as I say, it is entirely a matter of theory with all of us except Mr. Schulze-Berge as to whether the mercury does become dirty after working a long time. Then another thing I see about the pump is the question of cost. That pump, it seems to me, is one almost surely destroyed by a failure of the mechanical air pump, and if so, the question of costs of the parts which would be destroyed, is a very important one. I would like to ask Mr. Schulze-Berge, in case of failure of the mechanical vacuum, what parts of the pump would be destroyed, and also how long the pump will run before the mercury becomes soiled.

MR. SCHULZE-BERGE:—It is going to be in continuous use in a lamp factory. In experimental work it has been running sometimes four hours or so, according to the experiments to be performed with it. As to the cleaning of the mercury, in this experimental work there was no trouble about it whatever. As long as we have had the pump in use we have not cleaned it. This small pump has only been worked by hand, and it is to

some extent tiresome to turn it all the while, though it moves easily enough to be turned continuously.

DR. PERRINE:—How fast does the pump run?

MR. SCHULZE-BERGE:—The greatest number of rotations of this smaller pump was fifteen per minute, with the bigger one, I expect that we will run from ten to fifteen per minute, an evacuated space of the capacity of the ring being brought into connection with the receiver at each revolution.

I have only used so far solid tubes in other instruments, and in such cases I have never had any difficulty about the vacuum going down. The steel tubes in that pump Fig. 6 are about $\frac{3}{8}$ in. thick in the wall. I used a similar pump which I built several years ago on the other side of so-called Mannesmann iron tubing, and I have not had the slightest trouble about the vacuum, as far as I could get it then. The pump Fig. 6 is now at the factory to be tested, and I am going to try it in a few weeks.

When we designed the pump our intention was to do it by electric welding, but it was shown, when the electric welding process was tried on a number of joints of this sort, that there was a great risk in it. For that reason we have preferred to fasten the joints in this way: We screw the two ends of the tubes together with a soft platinum washer placed between, which platinum washer keeps back any mercury from moving out of the tube. On the outside of the tube we have soldered the joint, and the platinum washer prevents the mercury from affecting the solder.

As no other papers were then ready to be presented, the Section adjourned to meet at 10 A. M. the following day.

SECOND MEETING, WEDNESDAY, AUGUST 23, 1893.

The Section was called to order at 10 A. M. by the Chairman, Prof. Houston, who introduced Prof. D. C. Jackson, of the University of Wisconsin, who read the following paper on Underground Electric Construction in the United States.

UNDERGROUND WIRES FOR ELECTRIC LIGHTING AND POWER DISTRIBUTION.

BY PROF. DUGALD C. JACKSON,
Of the University of Wisconsin.

CONDUITS.

The advantage of placing all electric wires underground has been recognized from the very birth of the electrical industries (some of the earliest telegraph lines having their conductors buried), but difficulty of insulation and great first cost have prevented a general adoption of the system. Now, however, the unsightly appearance of overhead wires and the obstruction of streets caused by pole lines, as well as the obstruction to firemen in cases of fire in high buildings, have led the councils in nearly all large cities to compel the electric companies to bury their wires, at least in the most crowded districts.

From the operating company's standpoint there are many advantages in an underground distribution system. Reliability and safety are the strongest arguments. Sleet storms, fires, winds, and other similar causes of breakdowns in an overhead system are harmless when the wires are below the pavement. Underground lines have been operated for years without interruption due to trouble on the lines when proper care has been taken in their installation.

The methods of placing wires underground in this country are divided generally into two classes. (1.) Solid or built in systems. (2.) Drawing-in or conduit systems. In the first a conductor insulated and protected in some way from mechanical injury, is buried and cannot be reached for repair except by tearing up the street. In the second class, either bare

or insulated, are pulled into some kind of a conduit. They may be removed or repaired at any time, and additional wires to the full capacity of the conduits may be drawn in as they become necessary. For plants which are likely to grow, the drawing-in conduit system has proven altogether the best, and it is always easier to get at breaks and make repairs without delay to the consumer or obstruction in the street. The first cost is slightly greater than that of the built-in system, but usually not enough to balance the advantages. The *Edison tube* is the only important example of the built-in system in this country, and while it is very successful on low pressure work, the difficulty of maintaining the insulation, particularly at the couplings and junction boxes, for high pressure work, bar it from general competition.

Drawing in conduits of two classes have been used, insulating and non-insulating, but the former class have always failed to work and have gone entirely out of use for underground work. If a perfectly insulating conduit could be built, into which bare wires could be safely pulled, there would be a great saving in cost, as the insulation of a cable makes up half the cost of an underground system. But since it has been found absolutely impossible to prevent the condensation of moisture on the inside of a conduit, the insulation due to the conduit cannot be kept up, unless air can be completely excluded, particularly from manholes or junction boxes. Therefore at present the non-insulating conduit system is the method which is generally used for underground wires.

I.

A complete subway system consists of three parts: 1st, the conduit; 2nd, drawing-in manholes placed at convenient intervals; and 3rd, arrangements to get at the cables for the purpose of service connections.

Anything which will keep open a hole, smooth enough on the inside not to injure the cables in drawing in, and strong enough to protect them from mechanical injury for an indefinite length of time, will do for a conduit, provided there be nothing about the material which will injure the covering of the cables.

Of the large number of conduits which have been used or proposed, there are at present in successful use in America on a large scale four typical forms. Iron pipe, which may be either cast or wrought; cement-lined sheet iron pipes; tile, terra cotta, or clay pipes, and wood tubes.

The most generally used are the earthen ware conduits, and the most used of them is made of glazed terra cotta, in sections three feet long with one or more rectangular ducts, each capable of carrying at least three cables.

The walls are about one inch thick, and are supposed to be strong enough not to be cracked by the shocks of street traffic, when laid eighteen inches below the street surface. Rectangular ducts have a considerable advantage over round ones when the cables are properly drawn in. There is less trouble in drawing in several cables, as they may be arranged to lie side by side, instead of on top of each other, and any one may be then withdrawn at any time without disturbing the others. The glaze of the ducts has quite a high electrical resistance, but this is probably a disadvantage as the cable cover should be continuously grounded, to prevent shocks to linemen from static effects, or from leakage.

The terra cotta conduit is water tight and fairly gas tight when properly laid, but moisture can never be entirely kept out of any conduit, and gas is found to get through even the best built walls, if it is present in the soil in any quantity. The lengths of the terra cotta sections is short enough so that something of a bend may be made in laying, but as the bend is really a series of straight sections, with angles between them, it is rather difficult to pull cables around, and manufacturers recommend perfectly straight ducts. All irregularities on the inner surface are smoothed off before the tile leaves the factory, so there is no possibility of damaging the cable in drawing in and there is nothing about the material that could possibly, by any chemical action, injure the lead covering of the cables, or make the withdrawal of the cables difficult after they have been in service a considerable time.

There is a great diversity of opinion as to the proper depth at which a conduit should be laid. The principal conditions affecting this are the presence and location of other pipes and obstructions in the streets; the amount of tearing up to which the streets are subjected; and the method of distributing wires from the conduits. By some it is claimed that it is well to go below the frost line, but as the material should be one not cracked by frost, this is not usually deemed necessary. City ordinances often affect the position below the streets, and then the best is made of what may be unsatisfactory conditions. If it be possible, the

depth of the top of the conduit should be about two feet below the pavement, when the conduit is laid in concrete, as at that depth there is no danger of cracking from the weight of heavy teams in the street, as has been the experience where clay conduits have been laid at less depth. If clay pipe is laid bare in the earth (*i. e.*, without concrete), it should be generally about three feet deep for absolute security. The tile conduit should be, and where the best results have been obtained, is laid in a bed of from two to six inches concrete, and covered with concrete to that depth, so that when the whole has hardened it is like a continuous set of stone ducts. The top may be further protected by creosoted boards if the conditions make it necessary. Joints between the sections are made, either by wrapping the joint with several layers of burlap strips, soaked in hot asphalt, or by means of a tile sleeve over the joint which is cemented on. The latter joint is usually used when the conduit is laid in concrete, and in laying the conduit it is then usually sufficient to simply bring the sections together in a line in a trench, and fill in with concrete.

The durability of this terra cotta conduit depends somewhat upon where and how it is laid. If excavations in the streets are frequent there is considerable danger of its being cracked by picks and other tools in the hands of workmen. When concrete is used the conduit will "stand alone," even if all earth be removed from around it for some distance, and ordinary street excavations will not disturb it, but if the excavation is not properly filled in, the whole construction may settle after a time and cause considerable damage. No natural deterioration of this material can take place. It is absolute proof against heat and chemical action, so unless it be disturbed it should last forever.

House services are sometimes taken off from this type of conduit by means of hand holes in front of each house, using a subsidiary duct of iron pipe running into the basement; and sometimes the service wires are taken from the manholes and carried into each block by the subsidiary duct, whence they are distributed overhead from roofs or otherwise. The all underground method is the best, but it is more expensive so it is less frequently used. In either case a subsidiary duct is necessary and for this iron pipe is undoubtedly best, and is recommended by all manufacturers. If a system has a considerable number of ducts, and hand holes are to be used, the top layer should be used for

the distribution mains, so that the service can be readily taken off and shallow hand holes used. When for any reason the main conduit is laid quite deep a separate-duct or set of ducts should be run near the surface for distribution. Sometimes, in business districts it is possible to supply a whole square from a single manhole as the wires can run along under the side walks or pass through the partition walls of buildings. The method of distribution is practically the same for any of the forms of conduit in common use except the Johnstone conduit, which may be tapped into anywhere.

The experience of those who have used tile conduits seems to be very favorable, especially in the smaller cities. In Washington it is highly praised, both by the telephone and electric light companies, and telephone companies in Baltimore, Chicago, Pittsburgh, Milwaukee, and other cities consider it successful.

In Milwaukee an ordinary cement sewer pipe has been laid in the same manner as the tile, with cemented joints but no concrete, and it makes a very fair conduit which is a little cheaper than the special form. The pipes are softer than vitrified tile and therefore more liable to mechanical injury, but the system has not yet been long enough in use to fully decide on its comparative merits.

The simplest of all conduits and one which is used quite generally is a common wrought iron gas or steam pipe, either laid bare in the ground or in a bed of concrete. Ducts are usually of 2 in. to 3 in. pipes, and since a 3 in. pipe will carry four electric ordinary light cables the system is economical of space in the streets. One cable can be pulled out when the others are in the ducts, but the practice of handling cables separately when several are in one duct is not advocated by the most experienced. Joints in the pipes are made with a sleeve screwed on with a vanishing thread, which is cut so that the ends of the pipe come close together inside the sleeve. The sections of pipe are generally 20 ft. long.

When properly joined the pipe is of course water tight, but gases get into the manholes as in all other systems. The great advantage iron pipe has over all other forms of conduit, is its flexibility. It may be bent in any direction at any point, to avoid obstacles in the streets, and it should always be used when obstacles are particularly numerous. Some authorities claim that a conduit should never bend, but experience in New York and

Chicago proves that cables can be pulled easily around several bends with radii of three feet or less.

The best method of laying iron pipe ducts is in concrete, with the pipes about one and one-half inches apart. It is sometimes best, as an extra precaution against mechanical injury to box it in at least on the top and sides with creosoted plank. Pipe may be laid bare in the ground but it is then less durable. Iron has been found to have no bad effects on the lead covers of the cables, either while drawing in, or by chemical action after they are in, although it is possible for rust to so fill up the ducts that the cables cannot be easily withdrawn. The only bad feature of this form of conduit is its magnetic qualities. If an alternating current is carried through an iron duct, and the return wire is in another duct, the self-induction is greatly increased and the loss of pressure is considerable. In one case, where the effect of iron conduits upon the loss of pressure in electric light cables was tested the loss due to impedance was found to be a considerable factor. Mr. Preece finds* a fall of pressure of two volts with a current of 7.2 amperes and resistance of .0088 ohms, when the conductors are thus arranged. He concludes that the losses are due to hysteresis and eddy currents in the pipe and is consequently opposed to the use of iron for this purpose. A satisfactory commercial remedy for the defects is to put both sides of the circuit into the same duct, and as close together as possible. A great many cables used in some of the cities are made with the outgoing and incoming wires duplexed together for this purpose.

An iron pipe conduit is more secure against mechanical injury than any other kind, especially if it be laid in concrete and protected by creosoted planking. It is said by those having experience that a laborer will try to dig around wood in the ground, when he will go right through concrete, so that wood is a considerable protection. Occasionally a crow-bar, driven down into the street for an anchorage will go through plank, concrete and all, but it will glance off the pipe unless it happens to strike very near the center.

The greatest cause of deterioration in iron pipe conduits is oxidation. The amount of this in conduits cannot yet be determined as they have not yet been in long enough, but other pipes, when laid bare in the earth, probably do not keep in good con-

**Electrician*, Apr. 29, 1892.

dition more than 25 years. If laid in concrete, the inside of the pipe only will oxidize, and it is claimed that the pipe might be entirely eaten away and yet leave a smooth duct through the concrete, but considering the quality of concrete which is ordinarily used, this is very doubtful. In New York, before ventilating blowers were put in use, a greasy deposit was found on the inside of the conduit, and this seemed to protect the iron, but since the conduit has been thoroughly ventilated to avoid gas explosions, this deposit has disappeared and the pipes show the effect of rust to a considerable extent.

The distribution of wires from iron pipe conduits is made in a similar manner to that for tile conduits, a special tier of ducts being used for distributing mains only when necessary. The Johnstone conduit is sometimes used for distributing from wrought iron pipe conduits. It consists of cast iron sections five feet long, containing two rows of square ducts. This conduit is laid bare in the earth, and joints are made fairly tight with plumbers' putty. Before every alternate house there is a removable top, and a place in the side of the conduit where a wrought iron subsidiary pipe may be screwed in, making it possible to take off services without expensive handholes or manholes. This conduit must be laid quite near the street surface. Cast iron lasts better in the earth than wrought iron, so the life of this conduit should be fairly long, but of course the danger of mechanical injury is somewhat greater than in a properly laid wrought iron pipe conduit with concrete. It lacks flexibility and is quite heavy, but seems to be the only distributing system worked out in detail and is quite successful in New York, which is the principal place where it, as well as the iron pipe conduit, is used.

Tubes of wood, treated with various substances to preserve them, have been manufactured by several companies and quite generally used. At present Philadelphia probably has in use a greater length of wooden conduit than any other city, though there is considerable of it in Chicago and Brooklyn. As used in Philadelphia, it is made up of pieces cut in this shape , laid one above another to give any desired number of ducts, and spiked down, the various pieces being kept in proper relative position by dowel pins. The thickness of the walls is about $1\frac{1}{4}$ inches, the top being usually covered with a 2 in. plank for extra mechanical protection. The commonest form of wood conduit is made up of $4" \times 4"$ pieces of wood with a $3"$

hole bored through from end to end. These are jointed either by a male and female union or by simply butting the ends together. For a preservative of the wood, oil of coal-tar, carbolineum and other compounds have been used. This conduit is by no means water-tight, but with proper cables it has been quite successful. It is less flexible than iron-pipe, but curves may be approximated by using short sections. One of the greatest advantages claimed for the wood conduit is its accessibility. The wood may be cut away at any point and connection made to the cables so that expensive handholes are not needed, but generally when the wooden circuit is used, the distribution is made from the drawing-in manholes. The greatest disadvantage of the conduit is the chemical effect of the preserving compound on the lead covering of the cables. The lead is entirely destroyed by chemical action in a short time, when in the presence of wood preservative, unless it is protected by hemp braiding, alloying with tin, etc. Since the life of braiding is limited, and tin does not alloy evenly with lead, the rate of depreciation of cables in these conduits is usually great.

The durability of the wood is a matter of dispute. It is claimed that the preservative sinks in deeper with time, making the wood almost bone-like after it has been in the ground a number of years, so that it will even turn the edges of the tools used to cut it. From the experience with wood similarly treated and used for other purposes, and what experience has been had with conduits, it seems that they should last at least thirty years, and probably much longer. Untreated wood which is considerably used in Chicago and elsewhere will probably not last more than fifteen years.

With regard to mechanical injury from the laborer's pick, the wooden conduit is as safe as any other, but a bar may be driven down through the ducts more easily than through iron pipe.

It is claimed in Philadelphia that wood makes the only really successful conduit, but there they have the advantage of a very efficient control of the underground structures which occupy the streets, so that its principal disadvantages are not felt.

The other type of conduit which is being used on a large scale is the cement lined iron pipe. The tubes for this conduit consist of a tough sheet iron shell, riveted, and lined with $\frac{1}{2}$ " of pure cement, no sand being used, and the inside being carefully smoothed. The pipes are made in eight foot lengths and of

various diameters. The weight per foot of 3" duct (which is generally used) is about five pounds, as compared with seven and one-half pounds for wrought iron pipe. It is claimed that the pipe is water and gas tight, and proof against acids and alkalis. Distribution is always effected from manholes or handholes, the subsidiary ducts being generally 1" wrought iron pipes.

The cement lined pipes cannot be bent, but some flexibility may be gained by using short sections connected together by ball and socket joints. Bends made in this way must be of large radius or cables will not draw in satisfactorily. Clay and wood conduits, as already noted, have the same fault of inflexibility.

The cement being smooth inside, the pipe is one of the best to draw cables into that has been tried. It is probable that there is no deteriorating effect on the lead from the cement, although under some circumstances it has softened so as to hold cables fast. It was feared that the cement would crack off, but this does not seem to be the case. The tubes are laid in concrete and protected exactly like the ordinary wrought iron pipe.

The danger of mechanical injury is slightly greater than with wrought iron gas pipes, as the sheet iron is too thin to be a protection, but the danger is slight when properly laid in concrete. The cement tube like terra cotta should last forever if not mechanically injured, even if the iron becomes entirely oxidized, provided it be true that the cement does not crack nor soften.

The main arguments made in favor of this style of duct are its durability, smoothness, and cheapness as compared with iron pipe.

All of these conduit systems are in successful operation on a large scale, but the period of use has not yet been long enough to prove positively that they will all endure satisfactorily. The users of each appear to be well satisfied with their conduit. Which to choose for any new installation should depend on the local conditions. When, as in New York, the streets are filled with a mass of pipe of all kinds, and a conduit may be broken into by workmen at any time, the flexibility and strength of the iron pipe are necessary, notwithstanding its greater first cost and probable greater rate of deterioration. Where underground work is temporary, as at the Columbian Fair Grounds for example, or where cheapness is the main element, the wood conduits are the best. It is probable that their effect on the cable and lack of flexibility balance the arguments in their favor, (such as durability,

continuity and accessibility) except for the above classes of work. The arguments in favor of cement lined pipe are smoothness and cheapness and it doubtless makes a very satisfactory conduit where the special arguments in favor of iron pipes do not apply. For use where (as in most of the medium sized cities of the country), there is still room in the street for a good sized conduit without many bends, and where the amount of tearing up of the streets is not excessive, the vitrified clay conduit seems to be best, as its smooth ducts are easy to draw cables into. It does not injure lead, cannot deteriorate in the earth due to any chemical action, and is cheap. The Johnstone conduit is excellent for a distributing system and would probably answer well anywhere where comparatively small capacity and no flexibility are necessary.

II.

Having thus examined the various methods of keeping open a hole into which cables may be drawn, the second part of a sub-way system, the manholes and handholes, must be studied.

Manholes should be placed at all points where branches lead off from the conduit. They should never be more than 500 ft. apart, which experience proves is the maximum length of cable that can be drawn in at one pull under ordinary circumstances. Their size and method of construction depends upon the kind and size of conduit, upon its depth, and very frequently upon city regulations. In a system to be used for railway feeders, where after the first installations men are not likely to work except at long intervals, some inconvenience causing loss of time to the workmen, costs less than the interest on the extra investment for large manholes, so that small ones can be used to good advantage. For electric light cables, especially where several companies occupy the same conduit, larger manholes are necessary. This is a matter which depends altogether on local conditions, which is also true of much else connected with underground conduit constructions.

An ordinary standard size for manholes is six feet square and seven or eight feet deep. When the conduit consists of few ducts, near the surface, a much smaller hole, 3 ft. or 4 ft. deep may be used, with a large cover so that workmen can practically stand in the street, while working at the cables.

The walls of the best types of manholes are of brick, laid in cement, and sometimes the whole is coated with cement, but this

is probably of little value. The character and thickness of the walls is determined by the importance of preventing gas and water from leaking into the manhole, and avoiding the destructive effects of vibrations caused by passing teams. A foundation of at least 6 in. concrete should be solidly put in for each manhole, as any settling is apt to throw the ducts out of line and in the case of terra cotta to crack the conduit, as well as disturb the street surface. Manhole covers are of cast iron and are placed on a ring casting set of the brick work. This casting should be well fastened down by anchor bolts or something of that kind, to prevent cracks being caused from the effect of vibrations. The covers may be either single or double, but as the outside cover can only be held down by its own weight, and never makes a tight joint, the double cover is better if it is desired to keep the hole absolutely clean, but in nearly all cities single covers are used and fair results obtained. In Chicago the telephone company use a cover with $\frac{1}{4}$ in. slots in it for ventilation, and still have no great trouble from dirt, although it is occasionally necessary to clean out the holes. The best form is where the inside cover is screwed down (much like the manhole cover of a boiler) on a rubber gasket, consequently making the hole perfectly tight. The inner cover should be of a form that will drain all water away from the gasket, and where it can be readily bailed out when the hole is to be opened. When the streets of a city are fairly cleaned and well drained and especially for small holes, the double cover is unnecessarily expensive, but in this case it is well to make the outer cover extra heavy and to use a hemp gasket under it. When double covers are not used connections from manholes to sewers are frequently made, and this should always be done where the location is such that there is any possible danger of filling with water.

Some arrangement should always be made for hanging the cables against the sides of the hole, so that any cable can be easily reached at any time, and so that men cannot easily use them for steps in entering the manhole.

Manholes made up of cast iron sections, creosoted lumber, and of concrete have been, and are, used to some extent, but the best practice all over the country seems to favor the brick walls, as strongest and best and fairly cheap.

For complete underground house to house distribution, some kind of a handhole or distributing box is nearly always necessary.

They are usually placed at the line of every second lot, two buildings being supplied from each box.

Handholes are of two types, surface and buried. The first has a cover like that of a manhole on the surface of the street, and it is in fact, a miniature manhole, with either a single or a double cover. The buried handholes have a cover below the surface, and are covered by the paving. When the box is used only for distribution this type is probably the best, as it may cost a little less and the pavement must be torn up clear to the hole in any event, when a service duct is to be put in. The presence of iron covers every 50 ft. in the street is objectionable. Handholes which are simply boxes into which the ducts open on each side, and in which there is a place for subsidiary ducts to enter, are generally about 2 ft. deep, and are large enough so that joints in the cable may be made in them—2 ft. \times 18 in. being a fair size. They may be built either of brick or cast iron. In the latter case the castings are frequently ring sections, built up to any desired height.

Some method of draining a conduit is necessary. The ducts may be laid on a slight slope, toward the manholes, which themselves should all drain to one point and water may be allowed to gather there, to be pumped out occasionally from the street, or sewer connections may be made. The later is unnecessary if no water can get into the conduit except by condensation.

An even greater enemy than water to the success of an underground system is gas. In nearly all the large cities the gas mains are in a leaky condition and the soil is full of gas. If the pressure is any lower in the conduit than in the street, gas will flow in, no matter how tight the walls appear to be. The objections to this are two: 1st, bad effect on workmen in manholes; 2nd, danger of explosion. The cause of gas in the subways, low pressure, suggests a method of keeping it out, that is to maintain a pressure a little above that of the street by means of blowers of some kind. This method has been a great success in New York. A special pipe (6") is laid connecting the manholes where openings of different sizes ($\frac{1}{4}$ " to 1") are made, depending upon the distance from the blower. A pressure of a few ounces per square inch is kept at the blower, and the gas seems to be entirely kept out, manhole explosions never occurring. The amount of air required is about 500 cubic feet per hour for a manhole, the amount for the conduit depending on the kind used. In New

York about one horse power is required at the blower per mile of subway. In cities of the second class, where gas mains are kept in a fair condition, the pressure system is unnecessary. The most common way of ventilating, used very successfully in Philadelphia and many smaller places, and with moderate success in Chicago, is to connect the manhole by a pipe with a hollow electric light pole, so that the pole will act as a chimney. By this means the proportion of gas can be kept quite low, and it is not expensive if the poles are conveniently arranged, otherwise the pipe must be carried up the side of a building or other convenient object.

The comparative cost of the different conduit systems is difficult to estimate, as it depends upon so many local conditions. It may be divided into cost of excavation and refilling, and the cost of material and laying of conduit. The first part will vary greatly with the kind of paving, depth of conduit, etc., but is nearly independent of the kind of duct used. The rate of depreciation of a subway has not yet been determined, but from the use of similar materials for other purposes, it may be estimated as being four per cent. or less for iron pipe, and less than that, for any of the other kinds if they are properly protected from mechanical injury. The cost of maintenance should be almost nothing, but actual figures for the conduit alone cannot be obtained.

At the conclusion of the reading of Prof. Jackson's paper, the Chairman declared it to be open for discussion.

MR. M. D. LAW:—Mr. Chairman and gentlemen: I have listened with great interest to Mr. Jackson's description of underground conduits. It is a subject that interested me very much, indeed, a few years ago, and I have been through a great many experiments, trials and tribulations myself as regarding underground wiring. I have spent the winter in Washington and have watched with great interest there the introduction of their underground conduit system. It is, as Mr. Jackson says, a terra cotta pipe in square form made up in two sections. That seems to be the prevailing kind that they are placing there, and they are placing a very large amount of it, and from all I can learn, they are very much satisfied with it. In our construction we use the terra cotta round pipe. The construction in Philadelphia, as he mentions, is made up largely of creosoted wood, both in the square form and in the log form, and also of the cement-lined iron pipe. They are putting down a very large amount of it there, now, but I question very much whether it will be very successful. I cannot say very much to you in regard to recent

uses of underground wires and conduits, for the reason that my work lately has been in electric traction construction. I have spent probably about 13 years in electric lighting, but have recently gone into electric traction construction, and am there connected with underground trolley work.

That work, perhaps, might be of interest to some of you, though it does not just exactly hitch in with underground conduits; still we carry underground conduits through our tracks. The underground trolley that is in successful operation there consists of an open conduit 14" \times 20", made of cast iron yokes and iron shields on the side. The insulators are supported underneath the slot rail, the rail being U shaped, so that it protects it from all weather, all moisture, all wet of any kind whatever, and also protects it from any wire or foreign substance dropping through the slot and getting foul of the conductors. These conductors or metallic circuits are maintained so that we carry both positive and negative wires, with direct copper return to the machine. By repeated tests I have found this line has a very high insulation, often as high as ten megohms per mile, and can maintain under the worst conditions three megohms per mile, which is really above overhead construction. By close observation I have been unable to detect the least particle of leak in the worst kind of weather so that the matter of moisture carrying off the current I think we have got rid of. The line is cut every 500 feet; in fact it is an overhead trolley line placed underneath the track, uninterrupted in any place whatever, excepting that in every 500 feet we make arrangements by which we can open that line, so that if trouble does occur that line can be opened and tested, a decided advantage, and each section can be cut out independently of the others.

There is a manhole every 100 feet to facilitate the cleaning of the conduit and for drainage. In the yoke itself we have openings on each side through which we can carry six three-inch underground ducts from end to end of the line. This will allow us to carry all the feed wire that is actually necessary for any line, for, with the conductor itself, it can be graduated in size and made of sufficient size that it will carry the current for a four mile road without the addition of feed wires, thus putting your entire distribution of copper into the trolley wire itself, and doing away with the expensive insulating cables. I am ready at any time, gentlemen, to give you a private explanation of this, and show you the insulators and trolleys, especially the mechanical working of the trolley which is a very ingenious instrument, and in that the success of the whole business lies, in the trolley itself, in its ability to remain on the wire. I am at your disposal at any time to give you this information.

THE CHAIRMAN:—There are a number of gentlemen here who are very competent to discuss this paper, and we shall be pleased to hear from them; but as our time is short we shall be obliged to limit them to five minutes each.

MR. T. D. LOCKWOOD, of Boston, Mass.:—Mr. Chairman and Gentlemen: I venture to differ from your chairman in one respect. I do not think there is anybody on the face of the earth who is fully fitted to discuss this very important subject—certainly not authoritatively—and I am sure nobody can do it in five minutes. I had not the privilege of hearing the paper from its beginning, but what I heard enabled me to ascertain that Prof. Jackson, had at least investigated his subject before he began to write it.

There is one thing, if there is nothing more, that the practical telephone man has to congratulate himself on, and it is this, that if he is not a pioneer in anything else, he at least is, in underground construction of electric wires. As early as 1882 the recommendation was made to the company with which I have the honor to be associated, that while it was thought to be impracticable, or, at all events non-practical, to carry on telephone transmission by means of underground wires, it was at least worth trying and it was tried; and the first instance of that kind of construction was simply iron pipes laid in concrete cement. Nobody knew how to make underground telephone cables, or any other kind of cables then. The cables were drawn into the conduits from manholes, and that construction existed from 1882 until I think about 1888, when the pipes grew too small for the cables, and the entire structure had to be dug up and a new one put down. I think Mr. Jackson has done well in dividing his subject the way he has into first, conduits, as to the materials, and then going through the several details of conduits, including manholes, pipes and other matters. Of course, in any discussion on underground construction, we have to think of the conduit first. It has been well said, I think, that the old notions that in preparing a conduit we had to look out for insulation, were erroneous, and are now properly obsolete.

It is not necessary, I conceive, to look out for insulation in a conduit. What we have to look out there for is something to protect your insulation, namely, a protective structure which shall take care of the cables to be drawn in. At one time, and not so very far distant either, a number of—electrical cranks I was going to say, and I do not mean that in any offensive sense, because it is the crank that makes the wheel go round—the number of underground cranks was innumerable and one of the favorite ways in which conduits were to be made was to have a plastic bituminous concrete, to dig a trench first, to stretch uncovered copper wires in this trench and then to pour the plastic concrete over it to harden. The concrete sometimes hardened and sometimes it did not. But when it hardened, it was frequently found, (and this I know from my own experience), that several of the wires which had been stretched in the concrete had hardened too, and had hardened together unfortunately, so that the number of wires in that conduit was reduced from about 40

to about 4. I venture to say, therefore, that the lines upon which success seems to have been attained in the construction of conduits, at least for telephone wires, are either the closed terra cotta blocks or else the cement lined iron pipe, and when I say this I do not mean to deprecate at all the iron pipe which is *not* cement lined, because I think there is a great deal of good about good iron. One difficulty at least which has supervened in the terra cotta block is that the blocks are so short and our streets so unstable that it is very difficult to keep those blocks in alignment unless very great care indeed is taken in the construction, and I wish to emphasize here what the two former speakers have themselves emphasized, and that is that success in construction of underground lines is to be made by a constant, unremitting and persevering attention to details which in themselves seem trivial.

I was brought up by a mechanical engineer; and possibly for that reason noticed that my friend Mr. Jackson spoke of man-holes.

Among my other duties I occasionally when a boy had to put rivets into boilers, but we never then called *the boiler, the man-hole*. We always called the place where we go into the boiler the manhole, and I venture therefore to make a verbal criticism upon the word manhole as applying to the vault to which the manhole leads, but I quite agree with everything Prof. Jackson said about the necessity of the ventilation of manholes, and the necessity of making them tight, because the failure to make such vaults tight has been a cause for the entry of gas into them and of consequent explosions; and that by the way is not new with us, since our British brethren found it out and had the same experience many years ago.

Another difficulty, and one which I refer to rather sparingly and hesitatingly and which will probably be referred to later on, by a gentleman who is undoubtedly better adapted to deal with it than myself, is the constant attack upon lead covered cables of heavy currents which come to the earth from various and extraneous sources. All the tin alloy in the world will not prevent such attacks upon lead covered cables. All the plastic or textile, covering in the world will not protect such lead covering, but, even if such protection *were* possible, I think it likely that the constant pumping of such currents into the earth on account of their deleterious action on gas and water pipes will ultimately have to be deprecated much more strongly than it is now. If we come to cables, and that we must come to cables I agree with the author of the paper, or else the gentleman that spoke after him—I forget which—who said that the important work of the construction was the drawing in of the cables; the drawing in of the cables however can be performed much more successfully than can the drawing out of the cables, and it is very necessary here that we should remember that the very cable which is put down and which is intended to do good practical work as to telephone,

telegraphy, electric light or electric power, not only requires to have good electrical properties, but it ought to have good mechanical strength; and the experience of some years teaches me that, for telephone work at least, a cable covered with an alloy of tin and lead, that has enough lead to keep it stiff, and enough tin to keep it from being easily damaged by the influence of creosote or, more properly, the dead oil of tar, is all right. One of the most important features of the underground construction is not so much in laying of cables down and building conduits, as in the construction of attachments at the end whereby to extend the circuits as they emerge from the earth. It is quite necessary to have first class stuffing boxes that the cables can be drawn out without damaging the construction proper, and there is no reason, I think, no real reason, why underground cables should not be continued clear up to the place in which they are to be used, except, perhaps, the value of providing testing facilities between the earth and between the office cable and between the switch-board and other appliances in which it is be used.

MR. I. H. FARNHAM, of Boston, Mass.:—Mr. Chairman and gentlemen: A member of your committee told me yesterday that he would like me to mention one or two facts which we have found in Boston in connection with this subject of underground systems, but I hardly feel as if we could do it justice in five minutes, although I will give you what I can. Allow me first to mention that the paper which has been a very interesting one, does not name among other large underground enterprises that of Boston. As a matter of fact, Boston stands only the second or third city in this country in amount of underground work accomplished. I have brought with me a little map showing the underground system of Boston proper, that is, the business part of the city, and I will allow any one who is interested to look at it. We have in Boston to-day over 8,000 miles of telephone wire under ground.

The question of corrosion of the cables due to the action of the railroad current which I am to speak about in particular is one which has not been touched upon this morning, or only touched upon by Mr. Lockwood, and one which certainly is interesting because, if we put our cables underground and we find that in a few months the cables are destroyed, certainly we have met something quite as objectionable as the destruction of wires overhead, and I will endeavor in five minutes to give you an outline of what we have discovered there and the method taken to overcome the trouble. We found in Boston, the power house of the railroad company being represented by this mark, (illustrating on blackboard) the trolley wires came at first from the negative side of the dynamo and extended out over the city and were of course negative. Now, the railroad tracks running through the city might be represented by this line A. Suppose B represents a car. The current in this case, the dynamo being grounded, takes the

direction of the arrows and in its course would come back to the dynamos here, traversing through the rails and car, to the trolley line and back to the dynamo. Now as we all know, the rails are only a part of the conductor, the earth and all metal conductors in the earth being also a part of the conductor, although the rails are reinforced in Boston generally by five large copper wires about the size of a piece of chalk or a little larger. The current flows considerably through the earth. We found by our experiments that a portion of the city near the dynamo—as we might expect—gave a condition in which the earth might be called positive as at *c*, but all over the city except near the station, the earth was negative to its normal condition.

The telephone cables began to go to pieces from a cause not at first known; but in August, 1891, attention was called to the fact that electrolytic action was destroying the cables in places. That little map (showing a map) represents the city of Boston. One of the power houses of the railroad is located at this point (indicating on map), and we found by measurement that all of the territory through the city, except a small portion near the power house, indicated negative to the normal condition of the earth and that this small portion here (near power house) was positive, and we found that all through the remaining district the underground cables were positive to the grounds. Now it is evident that where electricity leaves the cable for the earth electrolytic action may take place, and as I have stated we found this condition to be actually true. It was suggested a few months after this discovery that the railroad circuit be reversed. If we make the trolley wire the positive side and the ground the negative side of the dynamo we reverse the condition of things in this figure, and instead of having a large portion of the city in which the cable would be destroyed, we would confine it to a smaller portion near the power house. The experiment was tried, the trolley wire was made positive, it came from the positive side of the dynamo and the earth was made negative. Now of course the current is reversed. The current came out over the line and down through the cars and into the ground taking the same general course through the earth, but in the opposite direction, reaching the cables at all points remote from the power house and leaving them in the territory near the power house. In this manner the destruction of the cables was limited to portions of the city near the power houses. This (showing a second map) is the same map drawn after that change was made. The larger portion of the city was then free from electrolytic action, because the cables were then negative to the earth except in a portion near this power house and a portion near another power house in another remote section of the city. We attempted to remedy the trouble, at least to some extent, by connecting the cables with the earth by running a wire from the cables to a ground plate in each underground apartment for the carrying of the

cables, but this did no good whatever. We found that with a good ground plate in a moist manhole the cable measured about as many volts above zero as without the ground plate connected. Mr. Pearson, of the West End Railway Company, suggested that a heavy copper wire be connected at the power station with the grounded or negative side of the dynamo, and that this wire be extended out from the power station and be connected to our cables in the district where the corrosion was taking place. This experiment was tried by running out a wire or bundle of wires about seven-eighths of an inch in diameter. This conductor was connected with the positive side of the dynamo and extended through the district in which the cables were positive to earth. In every manhole the cables were united to this return wire, and that has materially reduced the amount of current which is passing from cables to earth. Indeed, excepting in some small portions of the city, this has remedied the trouble at least for the time being. It may be an interesting fact that notwithstanding the five large wires which are run through the streets in connection with the rails of the railway system in Boston, and in addition large return feeder wires which are placed overhead; there is yet passing from our telephone cables to this return wire, which I have described, hundreds of amperes of current at a low voltage. The main return wire, which is seven-eighths of an inch in diameter and is copper, is heated perceptibly warm to the hand by the amount of current which it takes back to the station. Illustrating the rapidity with which cables have been corroded, one covered with asphaltum, which was supposed to thoroughly insulate it, was corroded entirely through in the space of two months; even before the cable had been put into actual use, the lead covering had entirely been destroyed in places by the electrolytic action. I think this is all I can give you in the time that has been allotted to me.

MR. A. W. HEAVISIDE of London, England:—Mr. Chairman and gentlemen: I am tempted to say a few words on this occasion on account of the great emphasis that has been given by previous speakers to one of the difficulties that prevails in drawing out cables in the drawing in and drawing out system. Mr. Lockwood touched the crucial point, it seems to me, when he said that the chief thing was entirely the importance of detail. Now, we find with a very extensive drawing in and drawing out system, that if we take very great care in details, in having our pipes laid in short lengths, in perfectly straight lines, straight in plan and straight in section, then you have no difficulties, but where once you introduce curves, either lateral or horizontal then your difficulties arise and nearly every case where we could not draw cables and have dug up our pipes, we found that to be the cause of difficulty, What I mean to express in this (drawing diagram on the blackboard). Imagine that the surface of the ground. Your pipe must be thus; that is to say this is a section of the

ground. Now looking at the next point it will be another absolutely straight line and your next point another absolutely straight line. I do not mean to say that those are straight lines, but if you understand the principle, then the relation will be readily understood. You must have absolutely straight lines from point to draw point. Then there is another point. It is absolutely necessary that your system should be as hermetically sealed as it is possible. Your joints must be as perfect as you can make them all the way through, and your junction boxes at the points of junction must be as hermetically sealed as possible from gas or from anything else getting into them. You must keep a uniform atmosphere within your pipes and you must keep them clean and quite impervious to the atmosphere if it is possible. Well, then, I might after having made that point speak of a system of underground electric light distribution which exists in Newcastle which

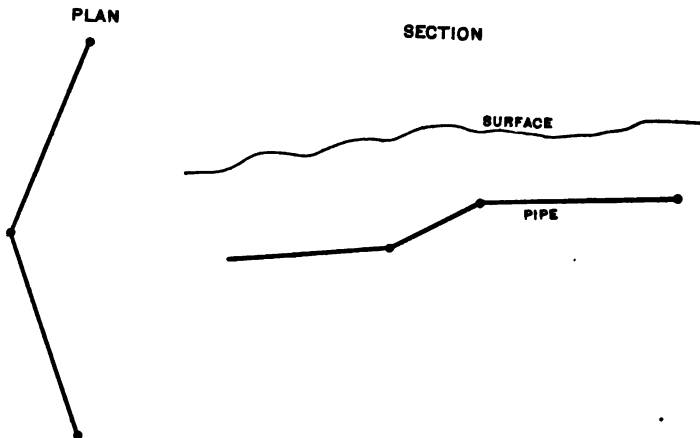

partly depends for success upon hermetically sealing and I think has some features of novelty in the way in which the cables are dealt with at the points of junction and at the distributing points, and that is this. There is a 2000 volt distribution. Concentric cables are used from point to point and at the junction boxes these concentric cables are bared and placed upon porcelain insulators. Each insulator is so fitted with terminals that it practically becomes a test box, and at any point you can sub-divide your system all over the city and distribute or rearrange your circuits according to circumstances, as for instance some imperfect cables burnt themselves out and also their neighbors. Well, in order to make that repair right and distribute over ten miles of pipes through the city, in an ordinary way, under the most expeditious systems that you could devise, it would take 24 hours; but we fortunately had an alternative, another way round, and therefore they immediately went to these distributing boxes, rearranged the

connections and the whole service was resumed in this way, and the lights were not out more than one hour. Well, the novelty naturally would be the method of insulation, and as I know your nation is exceedingly practical I have brought one of these porcelain insulators which will speak for itself far more forcibly than I could in words.

MR. DE CAMP, of Philadelphia:—The only reason I want to say anything is because I have not had any experience. I suppose I will have in a little while. I have two or three questions I would like to ask and if any of these questions are out of order by reason of having been answered in the original paper, I will rely on that. I was not here in time to hear the paper read. Mr. Lockwood, in referring to the material used in conduits, spoke of the glazed terra cotta, of which I have some knowledge though nothing practical.

I would like to ask a question here, which I presume almost any one can answer, and that is, what are the merits or demerits, of creosoted wood which has no doubt been used quite extensively as any other material. Another point is, the action of currents on lead covered cables or any other metallic covering. The next query is the difficulty of pulling a number of wires in or out of a single conduit. On this point I have had some experience, and that experience has been that it was not an impractical thing to pull a given number of wires and proportionately a very large number of wires into a single conduit. It was not a very difficult thing to pull any one of those additional wires out individually. It was a very difficult thing and well nigh impossible to replace that single wire back among its fellows. However, if that could be successfully accomplished in two or three cases it so affected those wires that was the end of all of them for all time to come, unless the whole body was taken out. Furthermore, after a bunch of wires was left in the conduit for any length of time either by some action of the conduit, which was iron, it was almost an impossibility to draw them out. From that little experience my own judgment at this time is for wires that are at all likely to be replaced and taken out for any purpose or other, that it is necessary to confine yourself to a conduit containing one wire, and with that in view what work I am doing now is done in that line. There is one point that I am very much interested in because I am responsible for the investment of a considerable amount of money in that line, and if any one here can state for a fact that it is impossible to pull in a three-quarter inch cable into an inch and a quarter duct in lengths of 500 feet I want to hear from them on this subject. There is another point which I think every one is interested in, and which I apprehend there will be some difficulty in answering, and that is the effect of the current on this outer covering which we relied upon to protect our insulation from moisture and mechanical injuries and so forth. The nearest that I can get to it, independent of the expense of

putting it into the cables, but bare cost of the cable itself, will be a matter of some \$1,000 or \$1,200 a mile. If that cable by reason of this action of the current, is going to be destroyed in one, two or three years, it becomes a very serious matter. It becomes a serious matter if it is to be done in ten years. I believe it is accepted that an electrical current conducted through a copper wire of sufficient size has of itself no deleterious effect upon insulation. I have however, heard it asserted that where such insulated conductor is encased in lead, there is an action set up between the lead and the copper conductor which has a tendency to destroy or seriously effect the insulation.

These are points which I think are practical ones and I would be very glad to hear them answered, and I have no doubt several others present who are holding positions similar to my own would be glad to hear them.

MR. GEORGE W. BLODGETT, of Boston, Mass.:—Mr. Chairman: I did not intend to discuss this paper, but I might mention one or two facts which I think will be of interest. The superintendent of the Western Union Telegraph Company, in Boston, told me of a difficulty which that company had experienced in consequence of the street railway currents which I thought you would like to know. That company had quite a large office in Bangor, Me., with wires grounded in the usual way of Western Union Telegraph circuits, which after the electric street cars were started gave them a great deal of difficulty, and they resorted to various expedients to overcome the trouble. They tried grounding the wires in the middle of the Penobscot river, which as many of you know is a large stream, but while there was considerable improvement this was quite inadequate, and they were obliged to go seven miles out of Bangor in order to ground their circuits and be able to work the telegraph lines. He also told me that in Portland, Me., they had experienced a great deal of difficulty from the same cause, and at one time they were obliged to disconnect their batteries from the line, and used the telegraph between Portland and New York by the leakage current from the trolley wire alone.

In answer to one of the questions which Mr. DeCamp raised I can state some of my experience for ten years or more, in drawing wires into and out of iron pipes for electrical signaling apparatus. I have found it always impossible to draw one wire out of a pipe and replace it with a new one with any satisfaction. The way in which we are obliged to do that (if a wire is to be replaced) is to draw the whole bunch of wires out of the pipe, insert a new one in place of that which is damaged, and then replace the whole lot in the pipe. That can be done without serious injury, and leave the wires nearly as good as the original construction. That I have done, sometimes even filling the pipe practically full of wires, so that to draw them in was quite difficult, but not in very long lengths. Where a long length is re-

quired I have sometimes done the work successfully by leaving the pipe disconnected in short sections, and with couplings in position to connect the pipe, and then draw the wires through one of the sections at a time, and couple up the pipe after the wires are in. Considerable difficulty is often found from burrs and sharp points in iron pipes, due to carelessness or imperfection in its manufacture, so that it is necessary to inspect all wrought iron pipes quite carefully if they are to be used for this purpose, and also to remove burrs at the ends where the different sections are screwed together.

The chairman then called on Mr. T. D. Lockwood to close the discussion.

MR. LOCKWOOD:—I had no intention of arrogating to myself that honor, Mr. Chairman, and I think the discussion has largely closed itself, because every one of us, Mr. Jackson included, has fully, I am sure, appreciated the importance of sticking close to a text, which we have not had the opportunities of opening our bibles to examine, to see whether the minister is really giving us the facts. That could not be helped by Prof. Jackson, and we shall have an opportunity to remedy it at our leisure when we see the paper in print, but I wish for myself in conclusion simply to answer the very first of the questions propounded by Mr. DeCamp, which if I remember rightly was this—what are the merits or demerits of a wood conduit? In reply, I say (as an experience of 15 years enables me to say) that a wood conduit *has no merit*, and that the wood conduit is *one tremendous demerit*: It has, it is true, one *apparent* merit, namely, that of cheapness. I most strenuously object to any consideration of cheapness as a merit in anything. It is true that we frequently confine the two terms cheapness and economy, but I desire to say, and I should like to say it, because I believe a man ought to do his duty, even though he were dying, *that it is never economy to do cheap work*.

The Chairman then introduced Dr. J. Sahulka, of Vienna, who read the following paper on "Various Uses of the Electrostatic Voltmeter."

VARIOUS USES OF THE ELECTROSTATIC VOLTMETER.

BY DR. J. SAHULKA, OF VIENNA, AUSTRIA.

In the paper I intend to read before you, I shall communicate some measurements made with an Electrostatic Voltmeter, especially the measurement of the capacity of condensers, which are inserted in an alternating current circuit.

The great advantages of the electrostatic voltmeters in comparison with other voltmeters, especially when using alternating currents, are well known. They require almost no current; the readings are not influenced by the temperature and by the neighborhood of magnetic bodies; by enclosing the electrostatic voltmeter in a metallic shell, it can also not be influenced by electric bodies in the neighborhood. The excellent instruments invented by *Sir W. Thomson* are well known. They contain a fixed and a movable system. In the multicellular type the fixed system is formed by a number of pairs of quadrants. The movable system consists of an equal number of needles placed between the quadrants and suspended on a thin wire, (Fig. 1.) If the difference of potential between two points is to be measured, the movable system and the metallic shell enclosing the instrument is connected with the one point, the fixed system with the other point. The movable system is thus deflected; a pointer, which is connected with the system, enables direct reading.

The electrostatic voltmeters are generally used only for measuring potentials. They can also be used for other purposes.

I wish firstly to examine, how small is the current traversing such an instrument, when measuring an alternating potential difference with it, and how great is the capacity of the instrument.

That could not be done with any of the known methods, the charging current and the capacity being very small. The instrument I used was a multicellular voltmeter of *Sir W. Thomson*, range 80 to 400 volts; but the scale intervals are only between 120 and 220 volts, large enough to enable an exact reading. In order to get a suitable difference of potential, I transformed the alternate current supplied by an Electric Central Station, having 2500 full periods per minute, and a potential difference of about 105 volts, in the ratio of 1 : 2 by a step-up transformer. The potential difference e between the terminals of the secondary, was now measured with the electrostatic voltmeter. Afterwards a great graphite resistance r , having no capacity and no self-induction, was connected in series with the instruments. The volt-

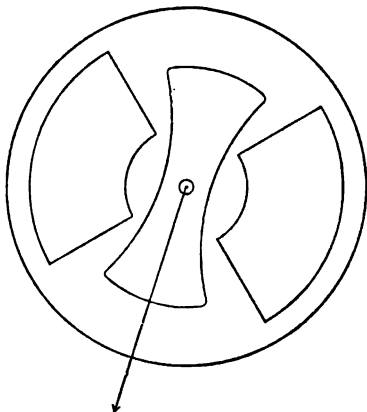

FIG. 1.

meter indicated now a smaller potential difference e . As the voltmeter is a small air-condenser, the phase of the potential-difference e , corresponding to the same, must be 90° behind the phase of the charging current c , whilst the potential difference e_2 corresponding to the resistance r , coincides in phase with the current c . (Fig. 2). We have therefore

$$e = \sqrt{e_1^2 + e_2^2},$$

e and e_1 being known, e_2 can be determined; we know, therefore, also the charging current $c \frac{e_2}{r}$. If the number n of periods per second is known, we can also count the capacity K of the voltmeter, for the equation must hold:

$$c = 2 \pi n e_1 K. \quad (1.)$$

The alternating current has 2500 full periods per minute; therefore we have to substitute:

$$p = 2 n \pi = 262.$$

In the Table I. are contained the results, which had been obtained with the voltmeter mentioned before. The values in the column r , are given in megohms, the values of e , e_1 , e_2 , in volts; the unit of C is one millionth of an ampere; the unit of K is one millionth of a microfarad. In the last column r , are given the relative impedances of the voltmeter expressed in megohms.

TABLE I.

r	e	e_1	e_2	c	K	r_1
11.05	207.2	195.3	69.2	6.26	122.	31.2
20.78	207.6	177.1	108.3	5.21	112.	34.0
33.16	207.6	154.6	138.6	4.18	103.	37.0
41.90	207.9	140.3	153.4	3.66	99.6	38.3
52.40	208.0	124.4	166.7	3.18	97.6	39.1

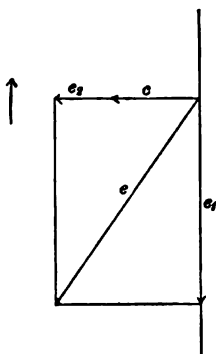

FIG. 2.

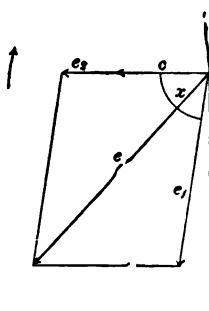

FIG. 4.

The results are represented graphically in the diagram (Fig. 3). The abscissæ represent the number of volts indicated by the instrument; the ordinate of the curve c represent the charging current, the unit being equal to one ten-millionth of an ampere; the ordinate of the curve k represents the capacity K , the unit being equal to one millionth of a microfarad. It is striking how small the charging current and the capacity of the instrument is. The capacity is greater for higher values of e_1 , than for lower values, as the movable system of the voltmeter is more deflected towards the fixed system. If there is no potential difference between the terminals of the instrument, its capacity has its small-

est value. Should the instrument be arranged in such a way, that the movable system would always be brought back to its zero position by the aid of a torsion head, then the capacity of the instrument would be constant, the scale could then be spread over the whole circumference, whilst in the present shape the deflection is always less than 90 degrees.

If the diagram (Fig. 3) would have been plotted for any electrostatic voltmeter, this instrument could be used for measuring

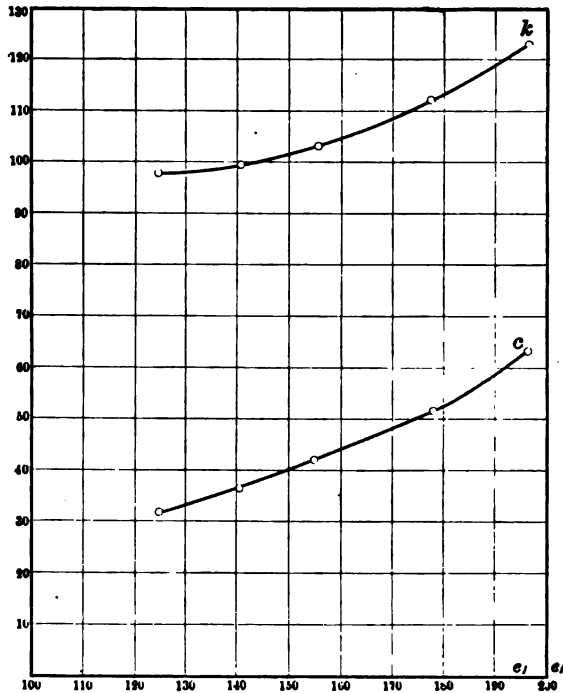

FIG. 3.

great resistances, which have no capacity and self-induction, and are of the same range like the impedance of the instrument. The resistances have to be arranged in series with the voltmeter.

As the alternating current, which traverses an electrostatic voltmeter, is exceedingly small, this instrument might be usefully employed for the *indirect measurement of the intensity of the magnetic field of converters or electromagnets, which are excited by alternating currents.* It is only necessary to wind around the

core a sufficient number of turns of thin wire, and to connect its ends with the voltmeter. As the instrument requires almost no current, the magnetic field of the core is not influenced by measuring it with the voltmeter.

The electrostatic voltmeter can also be applied very usefully for measuring the capacity of condensers, which are inserted in an alternating current circuit. I used for this purpose a method which is similar to that applied by *Toubert* for measuring the co-efficients of self-induction. I placed in series with the condenser a non-inductive resistance r , its capacity being negligible. The resistance r may be of the same range as the impedance of the condenser. For every condenser a suitable resistance r can be chosen. With the electrostatic voltmeter there may be measured the total difference of potential e , then e_1 corresponding to the condenser, and e_2 corresponding to the resistance r . If the condenser is an air-condenser, and if the frequency of the alternating currents is low, then a rectangular triangle can be designed (Fig. 2), of which the hypotenuse is equal to e , and the sides equal to e_1 e_2 . Now if the condenser has a solid dielectric, then e is no longer 90 degrees behind in phase with the charging current c , but by a smaller angle α (Fig. 4). The potential difference e_2 coincides in phase with the current c . The condenser placed in the alternating current circuit absorbs energy, for which loss Mr. Steinmetz has found the law, that loss of energy causes a heating of the condenser. We must conclude that the capacity of the condenser is not constant, but varies in every moment during one period like the co-efficient of self-induction of an electromagnet. In the same way, as special definitions are chosen for the intensity of currents and the electromotive force in alternating current circuits, we have also to define, what may be considered as the capacity k_1 , of a condenser, which is inserted in an alternating current circuit. That could be done in the following way:

The apparent resistance (impedance) of the condenser, that is, the ratio of e_1 to e , must be equal to the reciprocal of $2\pi n$ times K . The definition agrees with the formula (1). In the Table II are given some results obtained with condensers having paraffined paper as dielectric; K is the capacity measured with a continuous current electromotive force in the well known way, by observing the deflection of a galvanometer needle, the unit of the values K being one microfarad. The resistance r placed in series with the

condenser is given in ohms, e , e_1 , e_2 are the observed potential-differences in volts, the unit of the current c is one ampere, the value of K is equal to $\frac{c}{2\pi n e_1}$ and could be taken as the capacity of the condenser, when placed in the alternating current circuit; the unit of K_1 is also one microfarad. There was calculated also the angle of lag a according to the formula

$$\cos a = \frac{e^2 - e_1^2 - e_2^2}{2 e_1 e_2},$$

and the energy absorbed by the condenser, according to the well known method of Prof. Ayrton. This energy is named W , and is given in watts:

$$W e_1 c \cos a.$$

In the table are also calculated the values of c and K , according to the formula,

$$\frac{e_1}{c} \cos C.$$

$$\frac{e_1}{c} \sin \frac{1}{2\pi n K_2}.$$

The condenser having a solid dielectric, behaves like an air condenser having the capacity K and being connected in series with a resistance C . The quantity K_2 may be considered as the effective capacity of the condenser. I deem it useful, to calculate the effective capacity K_2 of a condenser and the loss of energy, which is caused at a certain difference of potential and a given number of full periods per second.

TABLE II.

K	r	e	e_1	e_2	c	K_1	a	W	C	$\frac{1}{2\pi n K_2}$	
										K_2	K_2
1.004	4000	206.9	147.8	135.2	0.0328	0.873	86° 9'	0.336	293.7	4363	0.875
1.004	5000	206.8	142.0	149.2	0.0298	0.862	85° 31'	0.308	346.6	4416	0.864
1.04	6000	207.5	120.1	161.1	0.0259	0.855	86° 2'	0.224	309.1	4454	0.857
1.004	7000	207.4	107.5	170.0	0.0243	0.863	85° 59'	0.183	309.7	4413	0.865
0.514	9000	207.6	139.7	145.3	0.0161	0.440	87° 30'	0.137	527.9	8661	0.441
2.618	2000	207.1	129.8	152.5	0.0763	2.244	85° 58'	0.697	119.7	1697	2.249

As the value of the $\cos a$ is calculated from a difference of nearly equal numbers, it is not quite exact; therefore also the value of the absorbed energy is not very exact. Should the value

of a and the absorbed energy be measured more exactly, every single experiment has to be repeated several times, in order to get average values. The table II. has been calculated only from single experiments. If the alternating generator runs with a constant speed the variation of K_2 is less than one per cent.

If we compare the values of K_2 , corresponding to the three condensers, taking an average value of the four first experiments, we find the same ratio (1 : 0.51 : 2.60) that have the values of K ; but the values of K_2 are less by 14 per cent. than the corresponding value of K . We conclude from that, that the condensers with a solid dielectric have a smaller capacity when placed in an alternating current circuit, than when they are charged with a continuous current electromotive force. Only the air condensers will not show such a difference. The cause of this remarkable fact is to be found in the behavior of the dielectric. The dielectric absorbs in spite of its great ohmic resistance, a certain amount of electric energy during the charging process. During the discharge a part of this energy is given back, the other part has been changed into heat. Therefore we get, when connecting a condenser with a direct current electromotive force, a too great deflection of the galvanometer needle, as we measure not only the electricity which is stored in sheets of the condenser, but also the electricity absorbed by the dielectric. In the same way we get a too great deflection of the galvanometer needle, when discharging the condenser, as the dielectric gives back a certain amount of the absorbed energy. When using alternating currents, the charge and discharge is finished in a very short time, namely, in the half part of a period. The dielectric has not sufficient time to absorb so much energy, as when connected with a continuous current electromotive force of the same size. During the discharge it gives back, therefore, also less electric energy. That is the cause why the condensers have a smaller capacity, when inserted in an alternating current circuit. The capacity will also be influenced by the number of full periods per second.

Considering the values of the absorbed energy W in the four first experiments, which belong to the same condenser, we find them in good agreement with the law of Mr. Steinmetz. According to this law the losses are proportionate to the squares of the potential differences, and should therefore be equal to 0.352, 0.281, 0.232, 0.186.

I measured in the same way, as it had been explained before, the capacity of Leyden jars, but in this case it was necessary to connect the Leyden jars in series with a graphite resistance of one megohm. As the electrostatic voltmeter has an impedance of 30 to 40 megohms, the current passing through it could no more be neglected if the capacity of the Leyden jars had to be calculated exactly. That makes the calculation more complicated.

Very small Leyden jars, which had the capacity of the same range, like the electrostatic voltmeter, were connected in series to the voltmeter. The potential differences e_1 and e_2 of the Leyden jar and the voltmeter have nearly the same phase and are inversely proportional to the capacities of these instruments; therefore the capacity of the Leyden jar can be calculated very easily.

I hope the method, that I explained, will be suitable to measure the true capacity and the loss of energy of condensers and concentric cables, which are inserted in alternating current circuits.

There being no discussion of Dr. Sahulka's paper, the Chairman then introduced Mr. Louis B. Marks, who read the following paper on "A New Incandescent Arc Light."

A NEW INCANDESCENT ARC LIGHT.

BY LOUIS B. MARKS, M. E., OF NEW YORK.

Electrical literature is replete with studies of the incandescent lamp as a source of artificial illumination; the performances of arc lights under a great variety of conditions have also been published from time to time. But the subject of the so-called incandescent arc, singularly, has received little or no attention.

In view of this fact it has seemed desirable to report at once, on a series of investigations, which, though still incomplete, have disclosed some remarkably interesting and important phenomena with reference to a new form of incandescent arc light. The experiments have been carried on far enough to demonstrate that the source of the illumination is *sui generis*. While possessing the main characteristics of the ordinary arc, it is also akin to the incandescent light, and may be said to constitute a mean between these two.

THE TYPICAL INCANDESCENT ARC.

The incandescent arc has been described as one in which the "two electrodes are in imperfect contact," the current thereby meeting with a high resistance and producing heat effects, which manifest themselves in the incandescence of one electrode and the formation of a number of very small arcs between the uneven parts of the electrodes in contact.*

On this principal, Reynier, Werdermann, Joel, Tommasi and others constructed lamps years ago, but for well known reasons none of these "semi-incandescent" lamps, as they were called found much practical application. The *Sun* lamp of Clerc and

* Julius Maier; Arc and Glow Lamps: p. 263.

Bureau was a modification of the others, the arc impinging on the surface of a block of marble or condensed magnesia between the tips of the electrodes. In this form there was a rapid waste of the non-conducting substance interposed, and a diminution in the efficiency of the light.

THE NEW INCANDESCENT ARC.

The *incandescent arc* to be treated of in this paper, differs radically from any of the forms alluded to above. In it, the electrodes are not in contact, while the current is indirectly used in maintaining all the products of disintegration of the carbon in a state of incandescence or opalescence.

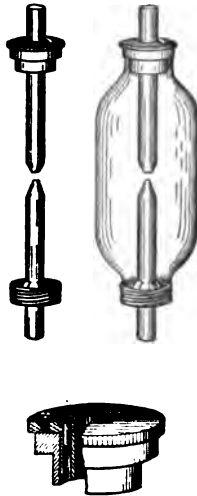

Plate A.

Plate A shows the main features of the appurtenance. It will be seen that the arc is enclosed in a small envelope, which is made of highly refractory glass. The envelope is closed at the bottom and provided on top with a metal plug having an opening in it just large enough to admit of the feed of the upper electrode. A fire-plug of asbestos-pulp insulates the metal from the glass. A valve shown in the plate allows the egress of gas, but prevents ingress of the air. With this construction the operation of the lamp will be as follows.

Upon the closure of the circuit, and the springing of the arc, the air in the enclosing envelope is robbed of its oxygen, the

latter uniting with the carbon of the electrodes to form CO and CO_2 gases.

The gases are brought to an exceedingly high temperature at which they maintain the carbon-vapor issuing from the arc. This vapor is deposited in the form of a thin coating on the internal surface of the glass chamber.

The expansive force of the gases may become sufficiently great, if no means of egress be provided, to rupture the envelope; hence, a small safety valve is provided for their outflow. The only possibility of ingress of air is through the narrow space between the positive carbon and the plug; experience has shown that after the temperature has been raised beyond a certain point the amount of air that enters in this way is inappreciable: in any event, the oxygen is immediately converted by combination.

It is important that the enclosing glass envelope be as small as possible, for the conservation of the radiant energy, and hence the efficiency will depend largely upon the size of the chamber. The heat which, in the ordinary arc-light is dissipated in the air, is here conserved and raises the temperature of the enclosed gases and vapor of carbon. The proper conditions being fulfilled, the lamp maintains its maximum efficiency shortly after the current has been passed through it, and glows like the incandescent, with the brilliancy of the arc-light. The arc proper is scarcely visible, but the entire contents of the chamber seem to be luminous, giving the appearance of a solid cylinder of light.

The pressure, as well as the temperature of the enclosed gases has a very important bearing on the performance of the lamp, and effects to a marked degree the character of the carbon deposit on the glass chamber. At this date no definite figures can be given, but it appears that a high tension is absolutely required to give good results.

The structure and constituency of the electrode are also pre-eminently important. Absolute purity of the carbons is imperative.

Investigators in this field have apparently found it impossible to obtain all the requisite conditions. Beardslee* mentions a type of lamp similar to the one under discussion, but whether the size or character of the arc-enclosing chamber, the nature or management of the gases, or the quality of the electrodes, or

*G. W. Beardslee, U. S. Patent, 265,737, Oct. 10, 1882.

other features made his arrangement impracticable, is not recorded. Suffice it to say, the comparatively poor grade of arc-light carbon manufactured ten years ago would alone explain his failure.

It is interesting to note here that attempts have been made at various times to save carbons in arcs by excluding the oxygen of the air. Baxter* devised several forms of arc lamp with this object in view. The subject has been more recently referred to by Thomson.† These experiments were attended with little practical success, not because the desired ends were unfeasible, but probably because, as in the case of Beardslee's apparatus, alluded to above, one or more of the requisite conditions had not been attained. It appears that the saving in life was more than counterbalanced by the loss in light. The "incandescent effect" was absent, and the unsteadiness of the arc itself was fatal. The results were almost identical with those obtained when the arc is formed *in vacuo*. In this case there is a tendency of the carbon to deposit as a soot on the sides of the vacuum chamber, an effect consequent upon the vaporized carbon in the arc being carried off and condensed again, as soon as the vapor escapes the heat of the arc stream.

But the requisite conditions hereinbefore named being once attained, the arc is really a beautiful phenomenon. It differs in many respects from the arc in open air, being especially steadier than the latter. The light, emanating from the incandescent vapor of carbon appears to issue from all parts of the small enclosing envelope, the area of the source of illumination being limited only by the size of the chamber.

EFFICIENCY MEASUREMENTS.

Measurements of the efficiency and candle power of the light were made in the laboratory of Cornell University. The method employed in making the efficiency tests was that used by Nakano‡ in determining the efficiency of the arc lamp, and subsequently by the writer in an investigation on arc light carbons.§ The ratio of luminous to total radiation of the lamp

*William Baxter, Jr., U. S. Patent, 288,157, Nov. 6, 1883.
 " " " " U. S. Patent, 306,993, Oct. 21, 1894.

†Elihu Thomson: The Electric Arc and its use in Lighting, paper read before the National Electric Light Association, Feb. 18, 1891.

‡H. Nakano: Efficiency of the Arc Lamp, *Trans. Amer. Inst. Elec. Eng.* vol. vi., p. 208, 1889.

§L. B. Marks: Life and Efficiency of Arc Light Carbons. *Trans. Amer. Inst. Elec. Eng.* vol. vii., p. 185, 1890.

was taken at different angles below and above the horizontal. The values obtained are given in Table I, where L equals luminous radiation, T equals total radiation, and $\frac{L}{T}$ equals radiant efficiency.

TABLE I.
EFFICIENCY MEASUREMENTS.

Mean Current = 9 Amp.

Mean P. D. = 55 Volts.

Angle.	0°	- 10°	- 20°	- 40°	- 50°	- 60°	+ 10°	+ 20°	+ 30°
L	7	12.3	17.	22.	20.5	13.5	8.5	7.	7.
T	155.	175.	180.	195.	180.	155.	135.	135.	135.
$\frac{L}{T}$.045	.07	.094	.113	.114	.087	.063	.052	.052

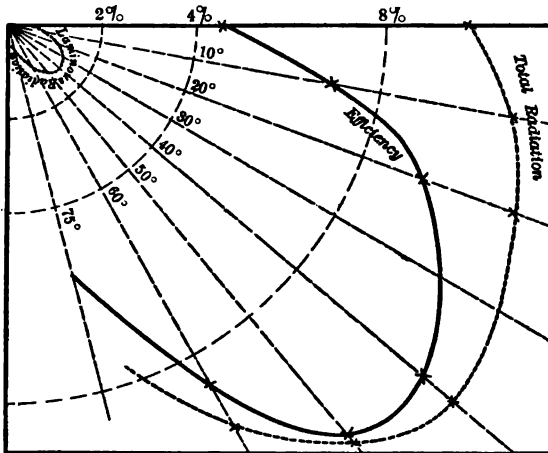

Fig. 1 Mean Hemi-Spherical Efficiency = 8.4%

Fig. 1 represents the curves plotted from these values, the dotted curves showing the distribution of luminous and total radiation, respectively and the full curve the measure of the efficiency below the horizontal.

The value of the mean hemi-spherical efficiency is obtained by integrating the curve, and is found to be 8.4 per cent. The mean efficiency of the ordinary arc is about 10 per cent.* The mean

* H. Nakano: l. c.

efficiency of the incandescent lamp, according to Merritt,* is rather below than above 5 per cent. The value obtained in the test of this new light therefore lies between those of the two present forms of electrical illumination, approaching, however, more nearly that of the arc.

While it is true that the average efficiency of the electric arc in open air nets about 10 per cent., it is questionable whether in commercial practice in this country this value is often reached. The writer has made tests of a standard brand of arc light carbon where the efficiency was only $7\frac{1}{2}$ per cent.†

Glancing at Fig. 1, we note that while the form of the efficiency curve differs entirely from that of the incandescent lamp, it

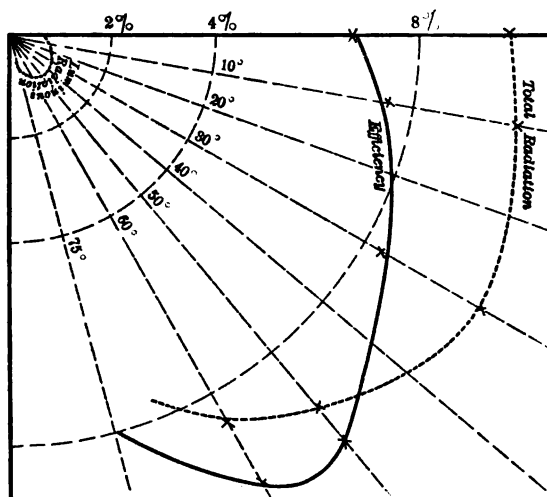

Fig. 2 Mean Hemi-Spherical Efficiency = 8.02%

is not unlike that of the arc. The distribution of light giving energy is, however, more uniform than in the arc, a fact which is more prominently brought out in comparing the candle power curves of the two. While the approximate law, *hemi-spherical efficiency*, = $\frac{1}{4}$ horizontal + $\frac{3}{4}$ maximum holds for the ordinary arc, the mean of several tests indicates that:

Hemi-spherical efficiency = $\frac{1}{2}$ horizontal + $\frac{1}{2}$ maximum, fairly represents the conditions manifested by the *incandescent arc* curves, Figs. 1 and 2.

* E. G. Merritt: *Amer. Journal of Science*, vol. 37, p. 167.

† *Trans. Amer. Inst. Elec. Eng.*, vol. 7, No. 6 and 7, p. 202.

Tests were made to determine the effect of initially coating the internal surface of the cylinder with various ingredients other than carbon. No marked difference in the efficiency was discovered. Fig. 2, plotted from values in Table II, represents a curve taken in this way. The mean hemi-spherical efficiency was 8.02 per cent.

TABLE II.

EFFICIENCY MEASUREMENTS.

Mean Current = 9 Amp.

Mean P. D. = 55 Volts.

Angle.	- 0°	- 10°	- 30°	- 50°	- 60°	+ 20°	+ 40°
<i>L</i>	10.5	12.0	14.0	15.5	14.0	10.5	8.50
<i>T</i>	155.	160.	170.	150.	140.	155.	150.
$\frac{L}{T}$.068	.075	.082	.103	.100	.068	.057

CANDLE POWER MEASUREMENTS.

Table III. gives the candle power measurements from which the curve, Fig. 3, was plotted. Distances measured along the radii give the candle powers for the various angles throughout the "zone of useful illumination."

TABLE III.

CANDLE POWER MEASUREMENTS.

Mean Current = 8 Amp.

Mean P. D. = 68 Volts.

Angle.	0°	- 10°	- 20°	- 30°	- 40°	- 50°	- 60°	+ 20°
Candle Power	218	283	455	590	595	515	450	170

DISTRIBUTION OF LIGHT.

It will be seen that the distribution of light as shown by the candle power curve differs considerably from that of the ordinary arc. Especially is this true at angles greater than 50° below the horizontal. The turn in the curve is not so sharp as in the arc, and there is much less difference between the maximum and the mean amount of light; in fact to the naked eye the intensity of luminous radiation does not seem to vary much from 20° to 60°

below the horizontal, while in the arc the change is very marked between these limits. Thus the formula of Gerard*, namely:

Hemi-spherical c. p. = $\frac{1}{2}$ *horizontal c. p.* + $\frac{1}{2}$ *maximum c. p.*, which may be used to advantage in arc light approximations, will not hold in this case; but the form of the curve, as well as the nature of efficiency curves above referred to, suggests the substitute—

$$\textit{Hemi-spherical c. p.} = \frac{1}{2} \textit{horizontal c. p.} + \frac{1}{2} \textit{maximum c. p.}$$

The mean or hemi-spherical candle power below the horizontal, obtained by integration of curve Fig. 3, equals 431, thus allowing 1.17 watts per candle, or 637.6 candles per electrical horse-power,

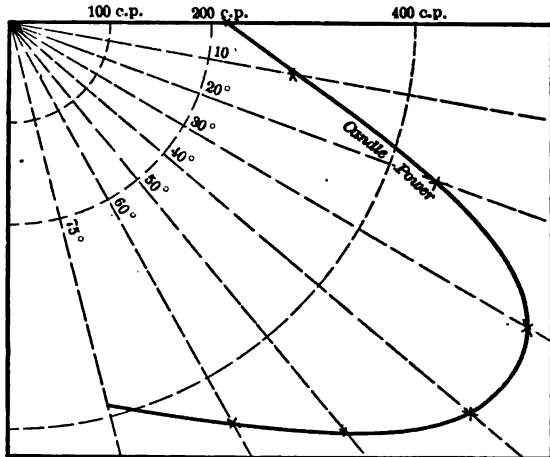

Fig.3 Mean Hemi-Spherical Candle Power = 431.
 Watts per " " = 1.17
 Candles per Elec.H.P. = 637.6

nearly three times the average illumination of the incandescent lamp using the same energy.

The results of tests show that the mean hemi-spherical candle power of the ordinary arc measured as in the above case, averages about 600; the mean watts per candle .84, or 888 candles per electrical horse-power.

Comparing the measurements with those of radiant efficiency it appears that the ratio,

$$\left\{ \frac{\textit{Hemi-spherical c. p. "incandescent-arc".}}{\textit{Hemi-spherical c. p., ordinary arc}} \right\} \text{ is considerably}$$

* M. Gerard: Candle Power of Arc Lamps. *Centralblatt für Elektrotechnik*, Jan, 1890.

smaller than the $\left\{ \frac{\text{Hemi-spherical efficiency, "incandescent arc"}}{\text{Hemi-spherical efficiency, ordinary arc}} \right\}$ ratio.

The explanation of this difference undoubtedly lies in the quality of *luminosity* of the light emitted by the *incandescent arc*. Nichols* has pointed out that the relative efficiency as determined by the ratio $\left\{ \frac{\text{luminous radiation}}{\text{total radiation,}} \right\}$ "does not coincide with that obtained from the ratio of watts to candle power, for the reason that the various rays which make up the visible spectrum, do not enter into the production of candle-power in proportion to their energy." Luminosity is a potent factor in determining the real efficiency of any source of illumination. Lack of time has prevented the investigation of this important phenomenon, but, at its maximum efficiency the light from this form of *incandescent arc*, though not so intense, unmistakably appears brighter than that of an ordinary arc of equal candle-power as interpreted by the photometer.

LIFE TESTS.

Oxygen being practically excluded from the arc enclosing chamber, prolongation in the life of the electrodes is an implied concomitant.

In the ordinary arc "while the positive carbon loses by volatilization from its tip or crater, and by combustion from its sides, the negative gains no deposit, but wastes at a less rate than the other, and by *combustion only*."†

Hence, if the exclusion of oxygen were complete, we might expect an indestructible negative. This condition, however, has not been fulfilled in any of the tests made thus far, but the results fully substantiate the theory. Absence of combustion on the one hand, and tension of the enclosed gases on the other, combine to greatly reduce the amount of disintegration of the positive electrode.

Table IV gives the results of life test with a pair of pure carbons, $\frac{1}{2}$ in. diameter, and specially constructed for the purpose.

The lamp was placed in the circuit of a constant current dynamo, running about eight hours per day; readings were taken

* Dr. Edward L. Nichols: The Efficiency of Methods of Artificial Illumination. *Trans. Am. Inst. Elec. Eng.*, vol. vi., No. 5, May, 1889.

† Elihu Thomson, l. c.

at given intervals and the total length of run was limited to 100 hours.

TABLE IV.

LIFE TESTS.— $\frac{1}{4}$ in. Carbons.Mean Currents $9\frac{2}{3}$ Amp.

Mean P. D. 55 Volts.

Initial length (+) carbon (inches).	Initial length (-) Carbon (inches).	Duration of run. (hours).	Loss in length (+) carbon (inches).	Loss in length (-) carbon (inches).	Life per inch (+) carbon (hours).	Life per inch (-) carbon (hours).
10.31	4.63	100.	6.81	0.69	14.67	145.45

Thus making 1.69 inches per hour as the average consumption of carbon in the commercial 350 watt lamp, run at $5\frac{1}{2}$ amperes and 50 volts,* we note that although 525 watts, or one and one-half times the energy have been expended in the case of the lamp under consideration, yet the life per inch of carbon consumed is more than *twenty times* that of the other. Indeed the figures show that the life of the negative was merely *one hundred times* as great as that obtained in commercial practice to-day.

The preservation of the negative is a very interesting feature of this type of lamp. There is a marked tendency towards deposition of the products of volatilization of the upper electrode, on tip of the lower, the carbon deposited; if not ruptured by the action of the lamp, forming an internal part of the negative.

In one case where, the arc having been sprung, the electrodes did not come in contact during the entire run, this "building up" process was beautifully exhibited, the negative electrode gaining practically all that the positive lost. The current in this instance was $10\frac{1}{2}$ amperes, and the P. D. 50 volts. The duration of the run was eleven hours.

OBSERVATION OF THE ARC.

Relation of P. D. to Length of Arc and Quality of Carbon.

The effect of the enclosed gases on the form and character of the arc presents a large field for investigation.

On account of lack of sufficient data no attempt will now be made to state much of a definite nature regarding this subject;

* E. F. Peck, carbon tests, paper read before the National Electric Light Association, February, 1890.

but it is hoped that the matter will be given due attention in the near future.

The difference in potential between the electrodes being equal, the *incandescent arc* is longer for a given current, than the ordinary arc; under some conditions it has been found to be almost twice as long. If we accept the conclusion of S. P. Thomson,* that "the arc is independent of the nature of the surrounding gas." we must then look to the effects of the tension or pressure of the heated gases upon the arc to explain this difference in length. It has been found that there is a constant increase of P. D. with pressure above atmosphere, for a given current and length of arc.† But in spite of this fact, the decrease in resistance of the arc under the conditions named appears to allow of a greater length for the same P. D.

FLAMING AND HISSING.

In the ordinary arc the carbon vapor carried off from the positive is consumed by the oxygen of the air before it can deposit on the negative. Hence the ever present "zone of flame" as distinguished from the arc flux proper is really a zone of combustion. In the *incandescent arc*, however, there is naturally no zone of flame, consequently the phenomenon of *flaming* common to the ordinary arc, does not occur. The arc tends to centre itself, being probably aided in so doing by the pressure of the surrounding gases; moreover, the slow consumption of the electrodes lessens the tendency to wander. With cored carbons there is a perceptible crater, but with solid pencils the tips become more or less flattened.

The quality of the carbon has an important bearing on the P. D. between the electrodes. Generally speaking, it has been observed that with soft fine-grained carbons the P. D. is considerably lower for a given current than with harder or course grained pencils. The tendency to *hiss*, however, is not so marked when the electrodes are consumed in the gas chamber as in the open air; in the former case the disintegration is so slow that the "electrolytic" vaporization, as it has been called, does not appear to explode the particles. It is interesting to note here that these

*. S. P. Thomson: On the Physics of the Voltaic Arc. Paper read before British Association, Section A, Edinburgh, August, 1892.

†. Dr. Louis Duncan, A. J. Rowland, R. I. Todd. *New York Elec. Eng.* vol. xvi. No. 274, page 99, 1893.

results confirm a theory of *hissing* advanced by Prof. Thomson a few years ago.*

THE ALTERNATING CURRENT "INCANDESCENT-ARC."

No measurements were made using the alternating current; but the appurtenance was applied to the alternating current arc lamp to determine the effect on the noise of the arc. The *hum* was in a large measure reduced, but whether the reduction was due mainly to the mere fact of the arc being enclosed in an air-tight compartment or not, is questionable. But, as the *hum* became much slighter after the lamp had been in operation several minutes, the action of the heated gases being then manifest, it is plausible that the diminution in the noise was not due entirely to the shielding property of the glass envelope.

While it has been proven that "the humming of the alternating current arc is due to the rapid periodic extinction and re-establishment of the discharge," † the singing tone may be greatly modified, if not entirely overcome, by the substitution of any incandescent arc of the Reynier type. A few years ago the writer had occasion to test an alternating current arc lamp trimmed with carbons which had been provided with a core of pulverized mica and carbon. The springing of the arc was accompanied by the usual *hum*, but as soon as the mica fused, the noise ceased. The conditions were similar to those of an *incandescent arc*, the plastic mica-carbon core constituting a high-resistance medium between the plus and minus electrodes. There was really no true arc. The amount of light was naturally greatly reduced. In the case of the *incandescent arc* first alluded to, there seems to be an approach to these conditions, the arc-stream acted upon by the gases enclosed in the chamber appearing to have a greater density, if we may call it that, than under normal circumstances. The amount of light in this experiment, was, however, apparently as great as in the direct current tests.

APPLICATION TO THE ARTS.

Unquestionably this form of *incandescent arc* must have a wide application to the arts. As a substitute for the ordinary

*. Elihu Thomson : *Trans. Amer. Inst. Elec. Eng.*, vol. vii, Nos. 8 and 9, page 274.

†. Dr. Edw. L. Nichols : A photographic study of the Electric Arc. *Trans. Amer. Inst. Elec. Eng.*, vol. viii, Nos. 6 and 7, 1891.

arc-light, where greater steadiness or longer life is required, its superiority will be manifest. And its utilization, where at present the incandescent lamp is the only satisfactory source of illumination, also presents a large field. The effective distribution of luminous energy and the color of the light, make it for many purposes a desirable mean between the incandescent and the arc.

As a standard source of illumination for arc-light comparison and measurements, it may be of much scientific as well as utilitarian importance.

The investigations have been carried out under the direction of Mr. Louis E. Howard, and many of the facts herein stated are due to him. The writer is also indebted to Dr. Edw. L. Nichols, Franklin L. Pope and Rob't H. Read for valuable suggestions; to Mr. C. Ransom for life tests, and to Messrs. Wm. C. Hubbard and E. S. Ferry for assistance in the efficiency and candle power measurements.

At the conclusion of the reading of Mr. Mark's paper, the chairman called on Prof. E. L. Nichols, of Cornell University, to open the discussion.

PROF. E. L. NICHOLS:—Mr. Chairman, I will only make a very few remarks on this paper. It seems to me that the contents are noteworthy, in that they seem to indicate two or three essential advances in the matter of electric lighting. Of course the difficulties of the arc light are plain. In the first place, there is the necessity of daily service in renewing the carbons, to say nothing of the expense of replacing the material itself. In the second place, the undue concentration of the arc light makes it for many purposes disagreeable and unsuitable, and we have been obliged to reduce the light for the purpose of getting diffusion, often times to the extent of losing half or more of the total candle-power. In these two respects we see here indications of a new condition of things. We have an arc lamp maintained apparently for hundreds of hours without the daily attention which the ordinary arc lamp requires. We have in the envelope surrounding the arc itself apparently the means of getting diffusion without great loss of efficiency; that is to say, the efficiency of this lamp appears from Mr. Mark's paper to be equal to the efficiency of the ordinary commercial arc-light. It would seem, then, that we have here a means of getting diffusion of light without so great loss as we get by sending it through an absorbent medium such as milk-glass or the opalescent globes sometimes used, and without so great a change in the quality. This form of lamp, we are informed, requires carbons of great purity. This may be for a

time a practical objection to its general introduction, but that seems to me an entirely secondary matter. Doubtless manufacturers of arc-lights will be able to fill this demand, and though the price of the carbons would be materially increased, the decreased consumption would more than counterbalance the increased cost.

Whether the change of distribution contained in this form is an advantage, depends of course, upon uses to which the lamp is to be put. With arc lights hanging overhead it is well, perhaps, to throw the light pretty well downward as in the ordinary form of distribution; still, on the whole, for most purposes I should think that the candle power curve of this new form presents a decided advantage over the forms which exist in the case of the arc lamp of the present day.

PROF. S. P. THOMPSON, of London:—I have made a great many investigations in this line, especially in regard to the behavior of the arc in various kinds of atmosphere. I am not inclined to think that there is any great commercial gain in making the carbons burn away slowly if it necessitates expensive carbons, a more or less complicated envelope, etc.

MR. GEORGE P. LOW, of San Francisco:—The very interesting paper of Mr. Marks, and the discussion call to mind an incandescent lamp exhibited by Mr. W. F. C. Hasson and myself in San Francisco, some months ago. In this there was no arc of any nature. It was operated under an extremely low electromotive force, between six and eight volts, from a storage battery. The inventor's claim is that by the application of a certain amount of magnesium the carbon may, under the action of current, be reduced to a plastic state. The lamp itself was a very crude one, but it presented the main feature of the usual arc lamp. The carbons remain continuously in contact until through a solenoid action they are raised and the plastic mass is drawn out to between $\frac{1}{8}$ and $\frac{3}{8}$ of an inch. The current varied between twenty and thirty amperes. The lamp was to have been submitted to Mr. Hasson and myself for tests later, but it was never brought back.

MR. MARKS:—Experimenting with that type of lamp we find the efficiency very low indeed, in fact, so low as to preclude the practical utilization of the lamp. The very fact that the products of volatilization of the carbons were not utilized in light in that form was fatal in connection with it.

MR. LOW:—I might state that Lieutenant Hasson and myself were engaged on the part of a would-be purchaser of the patent rights of this invention. Doubtless the inventor was aware of the woeful inefficiency of it, for he never returned to present the opportunity for us to test.

PROF. E. P. ROBERTS, of Cleveland, Ohio:—What has been the experience with the valve of this lamp. Has there not been a tendency for explosions to occur?

MR. MARKS:—In the earlier stages of this lamp there was a marked tendency to explosion, and on several occasions the attendants were forced to leave the room, but after perfecting the little valve we found that we had no further trouble in that respect. Indeed, I have not known a cylinder either to break or the gas to cause any disturbance for probably six months. Prof. Nichols alluded to the character of the glass which must be used in the incandescent arc of this style. It is very true that a great deal of difficulty has been experienced in procuring a glass suitable for this purpose, but after a series of experiments one of the glass manufacturers was enabled to give us a glass of a very refractory character which has withstood all the tests of temperature. Then in regard to Prof. S. P. Thompson's remarks, I would like to state that in the early part of the paper, before he came in, mention was made of the fact that the negative carbon wasted by combustion only. He has cleared that point in his discussion and has shown why the disintegration in the negative was not at all marked, and that it was due almost entirely, if not entirely, to the reflection of the heat from the positive electrode or "roasting," if I understood him correctly. In this type of lamp there is practically no waste of the negative electrode.

MR. GEORGE W. McDONALD:—This lamp appears to me to be rather an impracticable solution of the problem of making the carbons burn for a longer time than is now the case, because I have found that material is thrown off by the arc in such quantities as to cover the inclosing globe and prevent the exit of the light.

MR. MARKS:—In regard to that point I would like to state, or rather to refer to what was said in the paper regarding the quality of the electrodes. Absolute purity of the carbon is imperative, and no doubt in the case of the experiments of the last speaker, the carbons were, to a certain extent, imperfect, and judging from the results which he obtained, I am quite sure that the electrodes had a small percentage of iron in them, inasmuch as nearly all carbons manufactured, on this side of the water, at any rate, have a small amount of iron in them; even one-tenth of one per cent. of iron in a carbon is fatal to this form on light, because the iron is thrown on the internal surface of the glass cylinder in the form of an opaque coating. I have found with these experiments, that the pressure of the gas has tended to keep the body of the carbon intact and to prevent to a large extent, the deposition of carbon on the internal surface of the chamber, but with absolutely pure carbons of the requisite structure—and that is a very important matter—the deposition is very little. I ran carbons for hours and hours without any trace of deposit on the surface, but it took many months of experimental work to get a carbon which would answer that condition. Prof. Thompson alluded to the cleaning of the globes. We have found the coatings of the globes to be a practical benefit, inas-

much as it gives a more symmetrical distribution of light. A great many who have seen the light both with the coated cylinder and with the plain cylinder have preferred the former arrangement. The light seems to be softer, the luminosity appears to be greater. No exact measurements were made on this, but it is hoped in the near future we will know a little more about this phase of the subject.

The Section then adjourned to meet at 10 A. M. the following morning.

THIRD MEETING, THURSDAY, AUGUST 24TH, 1893.

DEVOTED TO A GENERAL DISCUSSION OF POWER TRANSMISSION.

The session was called to order at ten o'clock by the Chairman, Prof. Edwin J. Houston, who, after giving a brief statement of the work before the Section, introduced Professor F. B. Crocker, who spoke "On Direct Current Dynamos of Very High Potential."

DIRECT CURRENT DYNAMOS OF VERY HIGH POTENTIAL.

BY PROF. FRANCIS B. CROCKER.

Professor of Electrical Engineering, Columbia College, New York.

Mr. Chairman and Gentlemen: This treatment of the subject is not a formal paper, being merely a note of some experimental results which I have obtained with two direct current dynamos giving currents of very high potential—that is, from 5,000 to 11,000 volts. Machines of this kind have received comparatively little attention either from scientists or practical engineers. Nevertheless, facts of great scientific and practical importance can be derived from the investigation of this class of dynamos and motors.

Considering these machines historically, the first fact that meets our attention is that there exists a general and deeply-rooted idea that direct current dynamos of very high potential are not at all practical. This unfavorable opinion is particularly strong in regard to the use of such machines for the transmission of power for any considerable distance; in fact, such a system is considered to be almost out of the question.

It is chiefly with the object of bringing this system into the discussion of power transmission that I venture to present the following facts to the Congress.

The actual historical and practical facts are that the high potential direct current machines were more extensively and successfully operated when the dynamo first came into general use about 1880 than any other type, either direct or alternate current. Furthermore, their number and size have largely increased and the voltage at which they can be practically worked has been steadily raised until we now have sixty-light arc dynamos as the

standard size of large machine, generating about 3,000 volts and 10 amperes. Arc dynamos of 90 or 100-light capacity are also regularly made by several manufacturers, and 100 or even 125-light machines have been built. I happen to know of one station where there are four arc dynamos rated at 125 lights each, which run every night with a load of from 100 to 125 lights. These machines generate at least 5000 volts each. No great practical or other difficulty is found in operating arc machines, except that of danger to persons, but this is merely due to the high potential and does not depend very much upon the type of machine or character of current. In fact, the direct is probably safer than the alternating current of the same voltage. Nevertheless, when it is suggested to use direct currents in the transmission of power, we are usually told that nothing over 1000, or at the most 2000 volts, is at all practical. Why this discrepancy between the 5000 volts which are practically used in arc lighting and the 1000 or 2000 volts that are considered the limit of such machines for power transmission? Perhaps the first answer to this question would be to say that the current is limited; that when we have 5000 volts we cannot have more than 10 amperes, and if we want more amperes we must have less volts; consequently the number of watts is limited. For example, the machines which I cited and which are in practical and successful use for arc lighting give 5000 volts electromotive force, and only 10 amperes, and consequently have a capacity of 50 kilowatts, which is a small power, comparatively speaking, for power transmission, but is sufficient for ordinary arc lighting circuits. That, of course, is a fairly good explanation of the reason why such machines are not applicable to power transmission. But is there any such limit as 10 amperes to the current? I myself always look with great suspicion and doubt upon any such arbitrary limit as that. Experience has shown me that these arbitrary limits are usually imaginary. Now, it is a fact, however, that should be added to the historical consideration of the subject, that numerous attempts have been made to employ such machines for power transmission and other purposes, and it cannot be said that those attempts have been very successful; in fact, it can be said that they have generally been unsuccessful, but that is merely a negative fact.

In considering the actual construction of such machines, the first point is insulation which must be above suspicion. The

ordinary insulation resistance of one megohm is simply nothing for such machines. One megohm with 10,000 volts would allow .01 ampere to leak which would give 100 watts and that would rapidly heat and destroy the insulation. The insulation resistance should be at least 100 megohms. The next point is the commutator, because although the commutator might be considered the most important feature, as a matter of fact we must have the insulation before we can operate the machine at all, even for a few moments. The commutator, of course, must have a large number of sections. It must have a considerable thickness of mica insulation between the bars, more than is ordinarily employed; I should say about one-tenth of an inch. On the end of the commutator, where there exists the total voltage of the machine between two opposite commutator bars and the metal ring which holds the bars together, we require very much more thickness of mica insulation or some other insulation than is ordinarily given, at least $\frac{1}{4}$ inch. The next point is the material for the brushes, and I have found in that particular feature the most peculiar and important differences. In the first place, I consider that it is impossible to run an ordinary mica-insulated commutator with copper brushes at high potentials, the reason being that the film of copper which is worn off of the copper brushes by the mica is a sufficiently good conductor at very high voltage to carry many watts of current. At a low E. M. F. we do not have this difficulty, because even if we use copper brushes, the film of copper that is rubbed on to the surface of the mica would not carry a sufficient number of watts to cause any trouble, but at 10,000 volts, with a difference of potential in the neighborhood of 100 volts between adjacent bars, the film of copper, even although it is only infinitesimally thick, is sufficient to carry many watts of current.

I have found that with a potential of only 5,000 volts, which I have experimented with, copper brushes could not be used for half a minute; the copper would rub off upon the mica and immediately produce a ring of fire all around the commutator. Naturally one would use carbon brushes in such a case, because the current is small, and there is no reason why we should not use them. In regard to carbon brushes, I have also found that hard carbon is better, for the reason that it does not produce a deposit or layer of carbon on the commutator which might produce somewhat the same effect as copper, but not to the same

degree, because carbon is a much poorer conductor than copper. I have found that carbon brushes, with a comparatively small area of contact and a fairly strong pressure, not very great, but sufficient to insure good contact, seem to give the best results.

The machines I have actually constructed are two. The first was a small machine of one horse power capacity, the armature being of the toothed type. Some persons may think that form is exactly wrong, but the results do not seem to show that such is the case. It was very perfectly insulated with mica, and wound with double silk-covered wire. The potential of that machine was designed to be 5,000, and I have succeeded, by slightly raising the speed, in getting 5,500 volts from it. It had only 32 commutator bars. That machine is remarkable in the fact of its high voltage compared with its size, the armature being only seven inches in diameter and six inches long. The average difference of potential between *adjacent* commutator bars was $\frac{5500}{16} = 344$ volts, and the maximum was 500 volts by actual

measurement. It is interesting to compare this figure of 344 volts with that given in the ordinary rule for average potential difference between commutator bars which is 20 volts. This machine is, of course, not a very practical one, but it shows what can actually be done, and it has been run perfectly satisfactorily for hours at 5,000 volts, and for an hour and a half at 5,500 volts.

The next machine, which is more practical, is of five horse-power capacity, and designed to generate 10,000 volts. It did generate about 10,000 volts at the calculated speed, and gave 11,000 volts at a little higher speed which, however, was only 1,800 revolutions per minute and therefore perfectly practical. This machine has 108 commutator bars, a much more appropriate number for such a voltage. The current of this machine was intended to be between three and four-tenths of an ampere, which gives about its capacity. It must be remembered that those machines do not quite give their full capacity, owing to the fact that the wire is extremely small and therefore the percentage of copper in the winding is small, considerable space being occupied by the double silk covering. The current actually obtained from these machines was about two-thirds of their rated capacity. It would be unfair to deny the fact that there is sparking when we approach the full current capacity, and I think at the full cur-

rent capacity the sparking would be too great. These machines do not, however, have the slightest indication of sparking, when running on open circuit. Even the large machine, when generating 11,000 volts, does not show the least spark or effect of that enormously high potential.

The practical precautions to be observed in constructing or operating a machine of this kind are :

The insulation should be made very perfect and kept so. If the weather is moist, it would be unwise to start up, with the machine cold. It should be previously warmed up and thoroughly dried by a current of hot air or by passing through its armature an electric current which should be regulated so that it does exceed the normal armature current. The commutator should be of large diameter having a large number of sections and its surface should be kept perfectly smooth, in fact polished. The brushes should be carbon of fine grain. They should be fairly hard, but not gritty or "glass hard." A "wiper" or pad of asbestos may be pressed upon the commutator close to each brush to destroy any spark that may be formed. The potential of the frame of the machine and the armature core should be kept half way between the potentials of the two brushes. This minimizes the tendency for the insulation to be broken down. If the potential of the frame is equal or nearly equal to that of either brush, there is a very much greater risk of puncturing the insulation. In any well insulated machine the potential of the frame naturally settles about half way between the extreme potentials. If desired the potential may be forced to be maintained at that point by actually connecting the frame to the middle point of the commutator or in some other manner.

Both of the machines which I have described are in perfect working condition and can be seen in the Electrical Engineering Laboratory of Columbia College, New York.

Finally, in regard to the applications of these machines, I would say that the purpose to which I have applied them has been ordinary experimental work. For example, one of them, running at 3,000 or 4,000 volts, will light a Geissler tube very beautifully. It will produce any of the so-called electrostatic effects, that is to say, effects produced by very high potential and small quantity. It will, for instance, act very much like an electrostatic machine or a frictional machine, and produce attraction and repulsion of pith balls, etc. Another purpose to which the

machine is applicable is the testing of insulation, and, in fact, that is the principal use for which I made it. It might be asked why not use a high potential transformer for this purpose, as being more convenient and not having a commutator? I answer by saying that I do not think it is the same test. If the wire is exposed to a direct current strain, I do not think an alternating current test is proper. If a wire is subjected to a direct current strain, it should be subjected to a direct current test. If it is subjected to an alternating current strain, it should be subjected to an alternating current test. The other application is, of course, power transmission, and I would say that, of course, it is not necessary to have the total voltage generated by one machine. In any plant no one dynamo should constitute more than a comparatively small fraction of the total plant, and if there are four or five dynamos in a power transmission station, there is no reason why they should not be connected in series as well as in parallel, and thus sub-divide the potential. Each machine can generate a few thousand volts, two to five, and the total voltage could be obtained by the proper connection of several machines in series.

DR. N. S. KEITH, of San Francisco:—I am glad, Mr. President and gentlemen, to be able to controvert Professor Crocker's statement that there has been no practical application of high potentials for power transmission, and also to be able to confirm his prognostication that such a thing can be done. I will briefly state what has been done upon the Pacific Coast within the past six years in the way of transmission of power for practical purposes. In 1887 I constructed for the Pacific Power Company, in San Francisco, four dynamos, each having a capacity, or an output, of 40 horse power, or 30,000 watts. This was divided into a potential of 2,000 volts and 15 amperes. The dynamos were wound in shunt, simply. Practice has shown since that a slight compounding is necessary. I hold in my pocket a certificate from the Pacific Power Company, written only last month, stating that these dynamos have been in constant use for the last six years commercially and successfully. In 1890, three years ago, the power transmission by this system was very largely increased. They were first operated from Brush arc-light dynamos, coupled up for currents of 20 amperes, or rather 21½, as they were practically run. The voltage was approximately 1,200 to 1,500. This has been increased as the commercial uses of such motors have increased, to the extent of putting four of these Brush dynamos into a series, so that the potential differences be-

tween the extremes reaches at times to more than 5,000 volts. This system has been working continually and practically. It is supplying motors in San Francisco approximating 1,000 horse power in capacity; in fact, to-day in San Francisco there are but a very few motors, five or six all told, that are run by any other system. I need not make a statement of the conditions which led to this introduction. There are other power transmissions by this system in other places in the State. I only mention these as illustrations. I have installed at a mine in the State of Washington a power transmission plant running up to 2,000 volts, at times, with 40 amperes, and it has met with no difficulties. I have also in another portion of California a power transmission running up to nearly 2,000 volts and 30 amperes, with no troubles at the commutator. All that seems to be necessary is to make the commutator in a proper way, after taking care of the insulation. The insulation has to be practically perfect. The commutators have been made, not with wide spaces between them, but with the ordinary spaces, such as would be used in dynamos of lower potential, but the number of sectors have been increased. On the 2,000 volts 15 amperes plant, the number of commutator sectors is 84; on another of 70 horse power, 2,500 volts and 21½ amperes, the number of segments is 150. So the difference of potential between any two segments does not exceed about 30 volts. I have in my pocket a certificate from a man who has charge of one of those dynamos, which has an output capacity of 70 horse power, saying that it is the prettiest running commutator he ever saw. I need not consider the system of regulation, because time will not allow me to do so; but I will be pleased to show to any members of the Congress, after the meeting, or at any time during this or the next week, some of the motors, and describe to them the full details of this system which is in such eminent practical operation on the Pacific Coast. I am aware that nothing like this in this East has been accomplished, though many efforts have been made in that direction. The experimenters have, I believe, been unsuccessful where currents exceeding 10 amperes were used, and where the volts exceed 2,000 or 3,000.

THE CHAIRMAN:—I will ask Prof. Silvanus P. Thompson to close the discussion on Prof. Crocker's paper for the present, and then I will call on Dr. Louis Duncan to open the discussion on Multiphase Motors, and the Transmission of Power and any further discussion desired upon Prof. Crocker's paper will then come up.

PROF. THOMPSON:—I would rather reserve what I have to say on the main subject until I hear what Dr. Duncan has to say, but I take the opportunity to remark that we have here among us a delegate from Switzerland, M. Thury, who is well known to all of us. M. Thury is at the present moment writing down the details of five separate installations in Switzerland

where power is transmitted at high voltage, by direct currents, which he will give you later.

THE CHAIRMAN:—I will now ask Dr. Louis Duncan, of the Johns Hopkins University, of Baltimore, to open the discussion on "Multiphase Motors and Power Transmission."

MULTIPHASE MOTORS AND POWER TRANSMISSION.

BY DR. LOUIS DUNCAN.

Professor at Johns Hopkins University, Baltimore, Md.

It is best perhaps to explain how this discussion on the electrical transmission of power has come about. The question is one of the most important, if not the most important, confronting electrical engineers. Looking over the list of papers to be read before the congress it was found that none of them took up the question of multiphase systems and the transmission of power. We have among us a number of gentlemen who have had practical experience in the field and in the shop, as well as those who have a theoretical acquaintance with the subject, and if they will contribute their knowledge to the discussion, much useful information will be brought out. I do not think that any of us wish to conceal anything and there are many of us to whom it will be not merely interesting, but important to know the exact position of power transmission and distribution, the advances that are being made, and the possibilities of the future.

To begin the discussion I will briefly describe the working of a two-phase motor. Suppose we obtain from any source two independent alternating currents of a phase difference of 90° and suppose that these currents are used to magnetize the fields of a four-pole machine, one circuit being around the poles 1, 1' and the other around 2, 2'. Put in the field thus formed an armature wound with coils short circuited on themselves. Consider the armature at rest and let us think what happens when we try to start it. Let one of the armature wires be in the position α at the instant that the current around 1, 1' is zero and that around 2, 2' a maximum. The variation of the induction through the

armature coils, due to the poles 1, 1' will be a maximum, because the current around 1, 1' is passing through zero; and the e. m. f. in *a* will be greater than that of any other coil because it is at right angles to the field 1, 1'. No e. m. f. will be induced by 2, 2' because it is a maximum and is not varying. In the armature, then, we have the greatest e. m. f. in *a* and there will be none at all in *b*; that in the other coils gradually decreasing from *a* to *b* according to a sine curve.

The direction of the magnetic field is across 2, 2' and if the armature is not moving we have the apparently desirable condition of an armature in a field, with the e. m. f.'s in the armature coils so distributed that we get the greatest e. m. f. exactly in the coils where it will do the most good, and if the currents were in the same phase with the impressed e. m. f. we would have for a

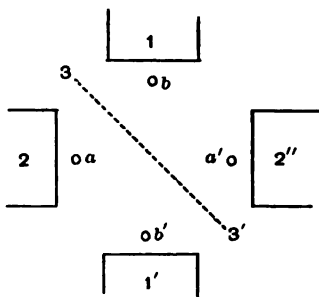

FIG. 1.

two phase motor a larger starting torque for the same armature heating than in a similar continuous current machine. Unfortunately the currents do not agree in phase with the impressed e. m. f., but lag behind by an angle which in the case we are considering—that of a stationary armature—is $\theta = \tan^{-1} \frac{B L}{R}$, the

time lag being $\frac{\theta t}{2 \pi n}$, t being the periodic time. Now while the current is reaching its maximum the condition of affairs in the circuits 1, 1' and 2, 2' has changed. The current in 1, 1' has increased and that in 2, 2' has decreased and the resultant field has reached some position 3, 3'. The result then is this: When we attempt to start a two phase motor the currents in the armature coils are not in the best position respecting the resultant field, but the conditions are approximately those of a continuous

current motor whose brushes are displaced from the proper point of commutation. It will take more current to get the same torque and in most motors it takes very much more. To remedy this trouble there are two plans employed, the object of one of them being to decrease l , the other to decrease κ . The Stanley Company, to decrease the armature self-induction, embeds in the fields, short circuited coils of copper; they also increase κ by throwing a resistance in the armature circuits. I cannot say that the anti-self-induction device greatly appeals to me. If the pole space necessarily left vacant were filled with iron I think it probable that the effect would be greater than with the present arrangement. For the other companies they generally content themselves with increasing κ by a resistance which is cut out as the motor gets up to speed. Another excellent device is an auxiliary transformer which lowers the applied $P D$, just as we have to lower the $P D$ at the brushes of a continuous current machine by a resistance. However, no matter what devices are used I think it may be positively stated that every polyphase motor now on the market takes much more current to give the same starting torque than a corresponding continuous current motor and this is one of the important objections to the system, especially when such motors are run on the same circuits with lamps. The large current used on starting causes such a drop on the mains that the lamps are affected.

Consider now what happens when the armature is in motion. Referring to the figure, the coil α will now have two E. M. F.'s impressed on it, besides that of self-induction. One—of which we have been speaking—is due to the variation of the current in $1, 1'$, the other is due to the motion of α in the field $2, 2'$. The latter is a maximum when the former is a maximum and is zero when the former is zero so that their resultant is a maximum in the coil α under the conditions we have been considering, that is with $1, 1'$ zero, and $2', 2'$ a maximum. Our armature current is, however, in a better position than when the armature was at rest, for while the resultant field is moving around, the wire α is also moving and when the current reaches its maximum it is much nearer the field. A little elementary mathematics will show that the revolution of the armature has the same effect as making the lag of the armature a current, $\theta = \tan(p-p') \frac{L}{R}$ where p is the angular velocity of the field and p' that of the armature, instead

of $\frac{pR}{L}$ as when the armature was stationary. Now the electrical efficiency of the machine is $\frac{p'}{p}$, so if its efficiency is great the lag is small and the motor should work well.

This is the elementary theory of the machine, but there are some points of apparently theoretical importance which I believe are of immense practical importance, and which are just beginning to be understood. I have said that the efficiency of the motors is $\frac{p'}{p}$ and this is true if the applied e. m. f.'s and counter e. m. f.'s are simple sine curves. Suppose for example that the field inductions followed the field currents and that the field currents have a fundamental period of $\frac{1}{10}$ sec., together with upper harmonics of $\frac{1}{30}$ sec. and $\frac{1}{50}$ sec. Then, very roughly, if the armature period was $\frac{1}{3}$ sec. the efficiency of the energy of the fundamental period would be 90 per cent., of the third harmonic 30 per cent., and of the fifth harmonic 18 per cent. Broadly we may say that the upper harmonics will decrease the efficiency of the motor. It is not enough to apply a sine e. m. f. to the motor, but, the motor must be so constructed that a sine e. m. f. applied to it will give a uniform rotating field, and the currents induced in the armature must follow sine curves. It is the appreciation or partial appreciation of these facts which has made the polyphase motor a successful or partially successful machine instead of the practical failure it was a few years ago. Broadly the difficulties still to overcome are the excessive current required in starting and the loss in output and efficiency due to faulty design. As it stands, successful machines are being made and they will be improved.

Now, there is another piece of machinery that is of very great importance in this work and which I hope may be discussed, and that is the so-called rotary transformer. You can use it as a power transformer, or you can supply it with an alternating current and take a continuous current from it, or you can use it to transform the current and to give out power at the same time.

Suppose you have an ordinary four pole machine, the potential at any particular wire in that machine will follow a sine curve. The potential of any fixed point in space, for example, the point of commutation, will be constant. Now, suppose we have an armature going at a certain speed in the field of a four pole ma-

chine, then, as I say, in a particular wire we have this curve. Suppose we connect to that particular wire, one of the terminals of a two-phase circuit, and suppose at the same time our electromotive force applied varies just as the potential of the wire does, but this applied electromotive force, we will say, is just a little higher than the potential of the wire. Now, what will be the result? Suppose I put a brush at a (Fig. 2). Suppose I fasten to the commutator bar on which the brush rests at this instant, the wire to which one of the two phase leads is attached. Then we have a current coming in from our two-phase machine, and say the voltage at a is $+250$ and the instantaneous value of the alternating E. M. F. at c is $+252$; the current would come in at c and

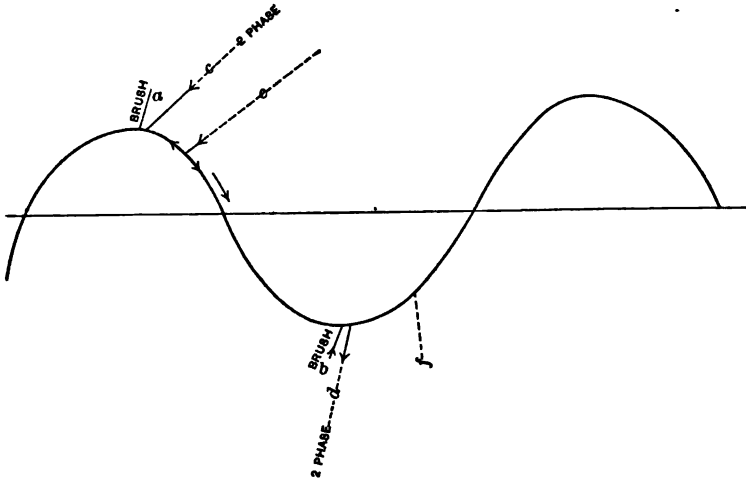

FIG. 2.

go directly out at a . In this particular case the current does not go through the conductors of the armature; it goes directly to the outside circuit. Part of the current again goes down to d because our applied voltage is a little higher than that of the armature, and 'it works against the electromotive force of the armature, and therefore, drives the machine as a motor. Now, suppose that the wire comes down in the position e . We have then part of the two-phase current passing through the portion of the armature from e to a ; this portion of the armature then acts as a dynamo. Part of the current will pass around to f . The portions of the armature from e to a and from b to f act as a dynamo, the rest as a motor (I am only considering half the

machine). There is one thing to be remembered, and that is this: the current that passes to the external continuous current circuit, does not pass through the whole of the armature, and this is very important, because an important question is, how much energy can be transformed by say, a 100 horse power, four-pole railroad generator, by converting it into one of these machines. Can you transform a 60 or 150 horse power? Here is another question which I hope will be discussed by the advocates of the two or three-phase system. Suppose you have a 100 horse power machine, can you transform more energy with a three-phase machine than with a two, and if so, in what proportion?

Now, we have here representatives of several of the companies, engaged in power transmission, and we also have some gentlemen who have had practical experience with different methods, and I trust that the discussion will be simple and straightforward, and that nobody will be afraid to say exactly what he means and say it very simply.

The Chairman then introduced Mr. Charles F. Scott, of Pittsburg, who spoke as follows:

EXHIBIT OF TESLA POLYPHASE SYSTEM AT THE WORLD'S FAIR.

BY C. F. SCOTT, OF PITTSBURG, PA.

An exhibit of power transmission at the World's Fair which is of exceptional interest, is the Tesla polyphase system which constitutes a part of the exhibit of the Westinghouse Electric and Manufacturing Company, in Electricity Building. The exhibit includes generators, motors, transformers, and other apparatus of various sizes and types. The system itself is not new in its general plan. There are but few features of novelty in the electrical system which have not been the subjects of publications of patents. The purpose of the exhibit is not so much to bring out what is novel in electrical invention as it is to give a complete exhibit of commercial machinery constituting the elements of a power system on a large scale. The exhibit will attract practical electrical engineers rather than those who are interested only in electrical inventions.

The purpose of the exhibit is therefore to show a complete working system for generating, transmitting, and distributing power on a large commercial scale. The system includes,

- I. A prime mover.
- II. A generating dynamo.
- III. Raising converters and transmission line and reducing converters.
- IV. Motors and rotary transformers for general power and electrical service.

The prime mover in general practice is water power, but in the present plant a 500 H. P. two-phase Tesla motor of the rotary

field type serves as a prime mover. The current for this motor is received from one of the 750 k. w. two-phase Westinghouse generators of the lighting plant in Machinery Hall. The number of alternations is 7200, and the pressure is reduced from 2000 volts to 200 volts before being delivered to the motor. The current is delivered to the rotating element of the motor through brushes resting on four collecting rings. The winding is a drum winding laid in small slots in the surface. The stationary element of the motor is of laminated iron set in an outside casting. Large copper rods are run through holes in the iron plates near the inner surface and are suitably connected at the ends. Resistances are put in circuit with this winding for starting the motor, and when speed is attained, these resistances are short-circuited, leaving this winding completely closed on itself.

The motor drives a 500 h. p. two-phase alternating current generator. This machine is of ordinary type of railway generator. There is a field of six poles which is exhibited by a small direct current machine driven by a 5 h. p. two-phase Tesla motor of the rotary field type. The exciter in general practice would be driven by a water wheel. The large generator delivers from four collecting rings, two currents differing in phase 90 degrees. The number of alternations is about 4,000 per minute, or $33\frac{1}{3}$ periods per second, at a potential of 360 volts on each circuit. The machine is also provided with a direct current commutator connected with the same winding, delivering current at 500 volts. This commutator would not be used when the machine is intended as an alternating current generator only. The current from this machine is delivered to a marble switch-board where it is regulated and connected with the various transmission circuits, as desired. This board will afford facilities for connecting various circuits with any one of the several generators which may be placed in a large generating station. The current from the switch-board is received by alternate current converters, or transformers by which the potential is raised in the present plant to 1,200 volts. In practice, the transformation would be to a much higher voltage, depending upon the distance of transmission. The transmission circuit conveys the current to the receiving station, where it is reduced by transformers to electro motive forces appropriate to the machines to be supplied. The current passes through a marble switch-board in which there are suitable provisions for operating the various machines in the receiving station.

The largest machine in this station is a 500 H. P. two-phase Tesla motor and rotary transformer. This machine is similar in general construction to the generator above described. The alternating current at 360 volts is passed into four collecting rings on the armature. Special connections of the field circuit are made for starting the machine, and when the motor has attained full speed, a switch is turned giving the final connections and running the machine as a self-exciting synchronous motor, which maintains the exact speed of the generator by which it is driven except in cases of extreme overload. The armature of this machine is provided with a double pulley with belts driving a Worthington pump and a 40 light Westinghouse alternating current arc light dynamo. The armature is supplied with a direct current commutator, connected with the same winding which receives the alternating current, and delivers direct current at a potential of 500 volts. This current is utilized for operating two 30 H. P. street railway motors mounted upon a standard Dorner & Dutton truck, and also a 60 H. P. direct current motor mounted upon an Ingersoll-Sergeant air compressor. The direct current also supplies a series of direct current constant potential arc lamps. The current from the switch-board is also carried directly to a 60 H. P. two-phase motor and rotary transformer, which receives the current at 36 volts and delivers direct current at 50 volts adapted to electrolytic work, charging of storage batteries, and is at present used for operating the large Schuckert search light in an adjoining space. The current from the switch-board also operates a 60 H. P. two-phase Tesla motor of the synchronous type, which is adapted for any kind of constant speed work. In the present exhibit, it is direct coupled to a 45 K. W. slow speed alternator of the constant potential type used for incandescent lighting. Current from the switch-board is also directly utilized for supplying incandescent lamps.

It is commonly recognized that the mechanical design and workmanship upon electrical apparatus has fully as important a bearing upon its successful operation as the electrical design. In fact, in actual experience, it is found that electrical enterprises which have failed or have been unsuccessful have been deficient usually in mechanical rather than in electrical elements. It is therefore of especial importance to note the mechanical features of a new system and to observe whether simplicity and strength and durability are insured. Visitors to the present exhibit are

struck with the general similarity in construction of the machines employed for widely different electrical purposes. The general form and construction of the large Tesla motor of the rotating field type, the alternate current generator, the alternate current motors, the rotary transformers, the alternating current arc machine, and the constant potential alternator have the appearance of general similarity.

The main castings are two in number. The lower one contains half of the field magnets and the bearings for the armature shaft. This simple form insures rigid bearings for the armature. The upper casting contains the remaining field magnets. The field magnets are made of laminated soft steel plates of high permeability, which are cast into the yoke of the machine. The armature is built up of thin disks of soft steel with grooves in the surface for receiving the windings. The armatures are drum wound with, in general, large conductors, placed in special heavy insulating tubes through the slots. This construction affords excellent insulation and protection of the wires, and the strains upon the wires, which in case of sudden heavy loads or short-circuits, may be very great, are transmitted directly to the iron core without chance for slipping or abrasion. In general, no band wires are required. The winding and connections of the armature of the multipolar machines for delivering direct current are such that there are always two and only two parts of the winding in multiple. This insures electrical symmetry which prevents the improper distribution of current in the armature conductors which would result if there were a greater number of armature circuits in multiple and the armature should get slightly out of center from excessive wear in the bearings, or other cause.

Attention is called to these points of simplicity and solidity of construction because they are so vital to the success of electrical working, and because the general improvement which is constantly being made in the mechanical development of electrical apparatus has been fully utilized in the design of this system. It is much to the credit of the system, and confidence in its success is assured for the very reason that it uses and makes but slight modification in types of machines which have been worked out in practice in other lines of service.

This system possesses characteristics which adapt it to a wide field of service, as it combines the requisites for transmitting power over long distances and for transforming it into suitable

forms for distribution and application to a wide range of uses. The employment of the alternate current transformer permits the use of low potential machines securing greater cheapness, efficiency, and a higher factor of safety, than is possible with high potential machines. By the use of alternating current the difficulties in construction and operation, which are inherent to commutators, are avoided on generators and motors. The low pressure of the machines is readily transformed to potentials adapted to great distances. The alternating current supplies two-phase motors of either the rotary field non-synchronous type or the synchronous type, and the rotary transformer transforms alternating into direct current. The work of this machine is equivalent to that of an alternating current motor driving a direct current generator. The two armatures, however, have been combined in one and placed in one field, and not only is the second machine eliminated, but the output of the single machine is greater than that of the two machines together, and the efficiency is increased and the commutation of a greater current is readily effected.

The alternating current circuits can supply therefore constant potential direct current at any voltage and is available for all kinds of work in which direct current is necessary or is preferable to alternating current. Incandescent lighting may be supplied from the alternating current circuits, and arc lamps may be supplied by direct current from the rotary transformer or from arc machines driven by synchronous motors.

It should be noted that the idea of complication from the grouping of several applications of the system with the transmission system proper. The transmission system proper ends with the switch board and rotary transformer in the receiving station. Other apparatus would be located where it may be required for use—distributed over a city or through mills and mines.

The alternating and direct current at various potentials for these various lines of service are secured from one generator and one transmission line. This is of practical importance both in small plants where it would be impracticable to install different kinds of service, and also in large plants where there are numerous generators. In such plants similarity and interchangeability of machines and circuits is of great economy and value in practical service.

Electrical inventors have done their part well in discovering principles and laws which form the basis for a complete electri-

cal system. Designers and mechanics have taken up these inventions and have developed them and constructed apparatus for practical working, which is now presented for the electrical engineer for adaptation to the various demands for the transmission and distribution of power. He may take up the work with full assurance, as plants are already in operation which place beyond question the practicability not only of general distribution and service but also of transmission over long distances and at high potentials. The successful installation and operation of lighting a plant for over 100 H. P. using 10,000 volts over a 28 mile circuit in southern California is an initial step which covers a distance greater than is required in a majority of the cases in which power transmission is proposed.

This exhibit of the Tesla polyphase system is the mechanical realization of one of the most unique and beautiful discoveries in electricity in recent years.

At the conclusion of Dr. Scott's paper, which was warmly applauded, the Chairman introduced Mr. W. F. C. Hasson, of San Francisco, who made the following remarks:

Mr. Chairman, I wish to say that it is a matter of great satisfaction to me to see that we have come down to the present time. I was very much afraid I was going back to California with the idea that I had only been indulging in reminiscences of successful failures, but now we have got down to date.

We are discussing a subject that is really of vital importance in electricity to-day. As a consulting engineer I represent a variety of companies in California who desire to transmit power electrically. The aggregate will amount to some 40,000 horse power, the distance running from 10 to 40 miles. Notwithstanding the fact that Mr. Scott has referred to the successful transmission of power for lighting purposes at San Antonio for 28 miles, the electrical transmission of power for long distances in California is a failure. Over a year ago the first contract for a definite transmission of power was closed. I see to-day an unhappy superintendent of a mine in eastern California up in the mountains, looking at his burnt out field coils after this generator had been in operation for less than thirteen days. Although this whole plant is very beautiful on paper; although it is all logical, the mere fact of the establishment of a small plant for operation in an exposition as we have here at Chicago and saying what may be done, does not establish the commercial success of long distance transmission of power. The points that are necessary in such machinery are first, that it shall from its inception and from its installation operate successfully; the second, that it shall con-

tinue to operate. The machinery must be so built that it will run not only a day or an hour, but for weeks and months: It must be borne in mind that power transmission is required almost invariably in places that are distant from railways, where repairs are impossible, and the machinery must be of such a nature, not only in its simplicity of construction but in its lasting qualities that accidents are almost impossible.

I believe in the transmission of power. I have been the apostle of it for a year in California, but we must definitely establish the fact to investors and others. No transmission machinery is of any use unless it will stand high voltages; we must overcome the list of defects and arrive at the correct manner of handling it. I wish to say definitely that to the investor in California to-day the successful machine for long distance transmission of power electrically exists only in the minds of the inventors and promoters, or in some beautiful advertisement.

I wish further to state that some four or five months ago I was called upon to decide ~~upon~~ certain plans for the transmission of 3,000 horse power some 20 miles. Most elaborate, most beautiful detailed descriptions of the methods arriving at these results were put before me, but not a single working drawing of any kind was presented by any one of the three companies that were competing for this installation. It must be recognized that these experiments are so extensive that they can only be carried out by companies. I have waited and waited for information, and all that I can arrive at is that one company says that 800 volts is the limit of multiphase generation. Another company says with equal positiveness that it does not hesitate to install 2,500 or 3,000 volts initially. Which is right? How are we to determine until these plants are installed and carefully operated. Again, we have been promised a long while a three-phase transmission in southern California. I understand that it is going out there now under special guard, and I trust that it will be taken care of and that it will arrive safely without any accident happening to it.

THE CHAIRMAN:—We should all like to hear from Dr. Louis Bell, who has given the subject of Power Transmission very careful study.

DR. BELL:—Mr. Chairman and Gentlemen: My friend, Mr. Scott, has so well described the characteristics of a typical polyphase system that as regards the general features of it I myself would have very little to add. I would only say that I am very glad that he has referred to the two-phase system as a polyphase system, because it gives us one word instead of two, and that all which applies to the two-phase system applies in varying degrees to all other numbers of phases. The general methods in the two forms of apparatus are the same in principle, and differ in such details as inventors have found desirable to introduce, so that all the polyphase systems are capable of doing practically about the

same work. The differences, it is only fair to state, are differences in degree which are far less than the differences between the polyphase system and any other system of power transmission. There are in general three methods which are at present offered and proposed for power transmission. That of the direct current, which Professor Crocker has been championing before us this morning; that of single phase currents and that of polyphase currents. Of the first I have only to say that in this country, at least, it has not been altogether a shining success. The experiments have mostly resulted in failures. I hope that M. Thury will be able to give us a far more encouraging report from the other side of the water. The great difficulty seems to be that which was suggested by Professor Crocker, that when the current becomes considerable we begin to get into trouble. Voltages which are perfectly practicable in a five horse power machine or in perhaps a 60 or 70 horse power arc dynamo, become difficult when you want to have 500 kilowatts or more in single units, and the cases of power transmission are frequent where there is a call and a very imperative call for units as large as 1,000 horse power. I am afraid that for these big units we need even more experience than Mr. Hesson has thought necessary for the solution of the general problem, before we get a successful direct current machine.

Second, we come to alternating currents, and we have to ask ourselves the very pertinent question, why do we want them? We want them for the reason which has been very well set forth by Mr. Scott, that when we get an alternate current we can do something with it. We can twist it around in an almost infinite variety of ways and set it to almost any application. Where we are dealing with a direct current, it is a direct current from start to finish, except as we transform it at the cost of more complication and an initial expense into alternate currents. Furthermore, we do not need the direct current for motors nowadays, and that is a sufficient reason why we should consider the alternating current as the coming thing in power transmission. So long as the direct current had a grinding monopoly of all the motor service, it was direct current or nothing. To-day that is changed. The single phase system, with which we have all been familiar in lighting for some years is, as we know now, largely through the experiments of our foreign friends, applicable to motor service also; not as well, however, I am sorry to say, as the polyphase system, nor is it as well adapted to the operation of the beautiful rotary transformers which are an essential feature, as Dr. Duncan has suggested, of the coming power transmission by polyphase currents. We know from experience that the single phase rotary transformer is less desirable in many ways than the polyphase one. As for the single phase motor, such as has been exploited abroad, I can say as a result both of what we have heard from other experimenters and from what I

know myself from personal experiments, that the single phase motor in its present stage of development can be considered as nothing else than a rather poor polyphase motor. It starts on the polyphase principle every time and with the objection that the rotary field established is not a circular rotary field but an elliptical one, consequently less efficient as a rotary field, and giving less efficiency in the motor. If we wish to start a single phase machine we have to use some method of commutation run by a synchronized motor, which has its well known limitations, or else some non-synchronous motor of the type which we have recently been hearing about, which, as I have just stated, is not as good as a good polyphase motor. If you are building an induction motor of any kind and set out to secure a single phase motor, you will have a most phenomenally good polyphase motor before you are through with the machine.

Then finally we come to the polyphase system. Essentially they operate on the same principle. We may, however, divide them into two classes, polyphase systems having two wires per phase, that is, having an independent circuit, and polyphase systems having non-independent circuits. In this latter case we get some simplification in the wires. A two-phase system with four wires one may fairly call practical. With three wires, by combining two of the conductors, it is somewhat simpler. The three phase system operated on separate circuits would require six wires, which I think we are all agreed is prohibited. Operated with combined circuits it requires but three wires, as few, in other words, as are required by any polyphase system. Furthermore, in all of the non-independent circuits, polyphase systems save copper over the direct current, the simple alternating or the polyphase systems with separate circuits. They save copper in varying degrees, the two phase about 72 or 73 per cent., the three phase about 25 per cent., and those systems which have more phases as a rule save less than either of those mentioned, the saving lessening with the number of phases. We need not concern ourselves with more than three phases, on account of the prohibitive number of wires required, even with composite circuits. We therefore have, as distinguished from the independent circuit system, which is so well exemplified in Mr. Scott's diagrams, a second kind of polyphase system with dependent circuits, interlocked circuits, which possess the valuable property of saving almost 25 per cent. of the copper, and also giving less self-induction and capacity on the line than simple alternating currents, so that for very long transmissions, they save both in copper and in that intolerable nuisance, line inductance. Line inductance I trust in the future will not be as serious a matter as it is now, or has been in the past, thanks to the suggestion of my friend Mr. Steinmetz in his paper yesterday.

As regards the general differences between the independent circuit polyphase and the dependent circuit polyphase system, one can only say that the independent circuit requires at least four wires. The dependent circuit requires at least three wires. This in the case of installing lights is a comparatively slight difference, because we must split circuits, anyhow, for lighting. In the matter of motors, the three wires are somewhat more convenient than the four. The great objection which has been raised against the polyphase system with dependent circuits such as the two or three phase system with three wires is that it does not regulate well, and the principle thing that I wish to put before you is that that criticism is absolutely ill-founded, as we know from positive experiments. In the first place, it is quite possible to arrange a dependent circuit polyphase system so that the difference between the different branches of the circuit, even under extreme conditions, will be almost unnoticeable. That, too, was pointed out by Mr. Steinmetz in his paper yesterday. The means of doing this are not always simple, and it is therefore well to state as a result of actual experiments that without any complicated means of compensation whatever, it is possible to obtain closely constant voltages in each branch of a polyphase system, independent of their operations in the other branches. If you cut off all the branches but one you will obtain a perceptible variation. If you cut off one of the three branches of a three phase system, you will obtain a variation which is scarcely visible to the eye.

With respect to the motors on the polyphase systems, I think we can readily appreciate from what Dr. Duncan has said that between 2, 3, 4 or n phase motors there is no very wide difference in principle, nor is there any very wide difference or any perceptible difference, one may say, in their operation on independent circuits or dependent circuits. The whole point of the matter is this, that if you are going to obtain equal results, whatever the number of phases, you must practically have a motor of about equal classification. In other words, for equally good results, the four phase motor would have to be just about the same sort of a machine as regards complication, winding, etc., as the three phase, and the two phase would have to be just about as complicated as the three phase. They would have to be nearly alike if you are going to get precisely the same results, but when those motors are properly designed I do not hesitate to say as the result of experience that they are decidedly superior to any direct current machine, and that is one of the strong reasons for using the polyphase system. In the first place these machines have no commutators, and in the second place it is almost impossible to burn them out. I have been experimenting with motors of this type for a long time, and I never yet succeeded, even under the strain of the toughest kind of experimentation in burning out a single machine in any way whatever, and I do not think that is a record

that could be well made with any sort of direct current motor. If they are overloaded they stop and will not burn out for a pretty long period. Under any ordinary circumstances they simply stand up to business without any commutation, without any complicated connections. They start quite well, as well as any ordinary direct current motor, and I beg leave to correct Dr. Duncan in his statement that 8 or 10 times the running current is needed to get a good start. The motors in respect to currents taken, start just about as a shunt motor starts. Furthermore the speed of these motors can be varied. It is non-synchronous, and when it is non-synchronous I do not mean to say that it is non-synchronous in the sense that a single phase motor is, but that it is non-synchronous in the sense that a series motor is. It is possible to run a polyphase motor at a widely varying range of speed, keeping up practically constant torque. The range of speed is practically variable from $\frac{1}{10}$ speed up to full speed, keeping constant torque all the time. This I think, escapes one of the objections which has been raised against polyphase motors.

One further thing I would say and then I am through. I want to defend the polyphase machine against the accusation of the lagging current; against the accusation that it will spoil the regulation of every dynamo that the mind of man has been able to invent. It is simply not so. If a polyphase motor gives a big lagging current at or anywhere near full load, it is proof conclusive that that machine has been badly designed; that the man who made it did not know how to utilize his magnetic circuit intelligently. There is no necessity of having more than ten per cent lagging current in any polyphase motor, and indeed one that shows much more than this I should consider badly designed. As an example of what is perfectly feasible and practicable in the way of reducing lagging current, I would say that I have experimented with motors of sizes up to 20 horse power, where the power factor is from 85 to 95 per cent. I also recently experimented with a five horse power motor, and I wish to deny once for all, the statement that the polyphase motors require an enormous lagging current. And more than this, suppose the current does lag 5 or 10 or 15 per cent. It is perfectly feasible to compensate the dynamo by very simple means against the lagging current, even where there is a considerable difference in phase. I recently tried such a compensating device of an exceedingly simple and practical description, with the result of holding the voltage of the dynamo practically constant from no load up to full load, when the load itself was of the worst possible inductive character. The machine itself was a little experimental affair, one of the 30 kilowatts, constructed out of an old alternator frame, it being the worst machine which I could pick for the purpose and selected intentionally, but the machine required two and one-quarter times the exciting current at full load that it did at no load. In other words, it is possible to automatically regulate the voltage of a

polyphase generator in spite of even a severe lag in the line due to the operation of motors, and finally this lag due to the operation of motors become evanescent when the motor is properly designed. I am satisfied if I have been able to defend the polyphase motor against this false accusation, and the polyphase systems, whatever the number of phases, against the accusations of insufficient regulation.

THE CHAIRMAN:—I will call on Mr. A. B. Stillwell of Pittsburg, to continue the discussion.

MR. STILLWELL:—I have not come here with any paper, and have no speech prepared; In fact, I just arrived and have only listened to the remarks of the last two speakers, so that I should be afraid to go into any elaborate or detailed discussion of the polyphase system as I see them for fear that I might be taking your time in simply repeating what has already been said.

I would like to call your attention, however, to the exhibit which has been described by Mr. Scott. I believe that exhibit marks an advance in polyphase work, and I know that it will enable those who examine it to ascertain for themselves what is practicable by this system on a scale that has not hitherto been attempted. In preparing this exhibit of the Westinghouse Company we have not shown small machines. It is no exhibit of toys or models or drawings. We have simply shown what we believe to be the best development of the polyphase system. Now, what have we accomplished in that system? We have one generator and one transmission circuit. At the receiving end of the line we have direct current and alternating current at various potentials, performing every kind of work to which electricity is applicable. I think that it is sufficient to show that the system is well worthy of careful examination and study. I have no doubt that further advances will be made, but we have here machines which mechanically are very excellent and electrically are capable of a very good performance. I think it would be interesting, if time permitted, to begin at the receiving end of the station and work back to the generating end from each kind of work that we perform; that is, begin with the incandescent lighting, and see how many lights and how many applications we have. If you will work that out for yourselves you will find that the efficiency is in all cases very high, and in all except arc lighting we have introduced the minimum number of machines and of transformations of energy.

We are aiming, of course, not at a partial solution of the problem of transmission, but at a broad and general solution, the door to which was opened by the invention of the polyphase system. There have been very many partial solutions, and we have as the result of such the direct current systems of limited applicability, and the single phase systems. We have here a system which performs all kinds of service over a single transmission circuit, and from a single generator. Of course, in a large sta-

tion, we would use several generators and as many circuits as might be demanded by the amount of power needed.

Now, I have one thing to say in regard to the evolution of this business. The parties interested are the manufacturers and those who propose to buy—users, and lately we have an intermediate class, consulting engineers, as yet less numerous on this side of the water than they are on the other. We are very glad to welcome them in their work, as they certainly have their place in protecting the interests of the customer, and also in explaining to the customer what the manufacturer is trying to sell him, to assist the manufacturer in convincing the customer that he is warranted in putting in the necessary investment to accomplish the result.

We have spent a large amount of money in putting in a very large and expensive exhibit of our machines and will be glad to exhibit it to those who may be interested and to whom we may properly extend that courtesy to make such tests as will, we think, satisfy them as to the performance of the apparatus. We have not attempted to show the insulation of our circuits for long distance transmission, although we might have run a circuit around the city of Chicago and come back to the switch-board, and carried our potential at 10,000 volts and operated it. That has been demonstrated in Germany over a longer distance and over a higher potential, and very high potentials are in commercial and successful operation in this country. Now, it seems to me that the consulting engineer is the man who must put two and two together, and solve this problem for us. He is the man to stand up to the customer and to the world and say, this thing is practicable and it is a success. It is not for the manufacturer to pay for the apparatus and install it and operate it and guarantee dividends as has sometimes been proposed.

THE CHAIRMAN:—I see a gentleman here who is familiar with long distance transmission, Dr. Otto Frick. I will ask him to make a few remarks on the subject.

MR. FRICK:—I have heard here speakers recommend to you the polyphase and also the direct current. I should like to say that no system is the best. I think the direct current system is a very good one, the polyphase system is a very good one, and the single phase system is a very good one for the transmission of power. For the purpose of demonstration I should like to give you some instances from the other side of the water. I will not speak of Genoa, as I suppose M. Thury will tell you himself of the transmission of power there, where they are operating with 6,000 volts and a perfect system of dynamos, etc.

We had in Germany two years ago a long transmission of 100 miles by a circuit up to 30,000 volts, but people seem to be incredulous when I tell them of it. They said it is very good for an experiment, but we should like to see such a system working for a long time. Well, gentlemen, I can tell you I was at

the works of Oerlikon two or three months ago and I saw there a transmission of power working which had been in operation for, I suppose, 15 months, at 13,000 volts. It was a three-phase current transmission on the same plan as the transmission from Lauffen to Frankfurt, the work being perfectly satisfactory all the time. Their motor was 300 horse power, constructed in the same manner as the generator.

Now, of the single phase system I said it was also good. I saw in Switzerland a 100 horse power transmission. It was lighting a mill. It was not a self-starting 100 horse power motor, but had a very good device for the purpose. There is a small single phase self-starting motor of two horse power to put in motion the big one. As soon as the big one was in phase it was connected in circuit and worked well as a motor. This little single phase motor is now constructed by Messrs. Brown, Boveri & Co., the well known builders, up to I believe 10 horse power, and I have seen these motors in perfect condition. They are put in action as a two phase motor, and as soon as it is running and synchronized with the generator, it is put on the main circuit as a single phase motor and runs in synchronism, and does not stop at an overload of 50 to 100 per cent. These motors we have in use in a little town near Munich and I can say that of the 15 motors they have there, there is not one that has given any trouble, and the people that use them are all well satisfied with the work they are doing.

I might conclude by repeating that no system is the best. One system may be the best for some special work, but there is no single *best* system.

THE CHAIRMAN:—It gives me great pleasure to call on Prof. Silvanus P. Thompson, of England, who is too well known to need any introduction.

PROF. THOMPSON:—Mr. Chairman and Gentlemen: May I first speak for M. Thury. He has asked me to place before you the following points: There is at Geneva a transmission of power at constant potential of 1,200 volts, with a simple continuous current, the motors being shunt wound. There is another at Stanzerhorn, working with a generator of 150 horse power at 1,500 volts and about 70 amperes. This works three motors, each of about 60 horse power nominally. There is another case of distribution with continuous current, but with excitation, with the generating plant consisting of dynamos in series. This is from Biberist to Rondchatel, a distance of 29 kilometers, about 20 miles. Two generators of 200 horse power each, current of 40 amperes, running at 3,500 volts and tried up to 4,500. A fourth installation is at Genoa in Italy. There is a continuous current of 45 amperes, eight dynamos as generators, all joined in series, each nominally about 1,000 volts and each being about 60 horse power, but these eight do not run quite at 1,000 volts each, the line being 6,000 volts is ordinary work,

because if you keep the current constant the volts will vary according to the demand at the other end. There are two circuits feeding motors, varying from five horse power to 100 horse power, and from 100 volts to 2,000 volts, and these are all examples of practical installations for which M. Thury makes himself responsible.

Now, to speak for myself, first of all let me deal with the continuous current problem. Let me point out that for other purposes than the mere furnishing of arc lights continuous current machines have been constructed to work at high voltages. In London Mr. Esson has designed various dynamos, working at from 1,000 to 2,000 volts, using commutators of the ordinary kind, but when I say commutators of the ordinary kind I mean that they were the ordinary straight bars of hard copper or something of that kind, but they were especially insulated and they took special precautions against sparking. In one machine they adopted the plan of wiping out any ordinary spark that might occur upon the commutator by imbedding the whole thing in a mass of asbestos, which wiped out any spark which might be formed under the brush. It was a rough and ready device, but it "got there."

Again, in Germany Mr. Lavier (?) has carried out many examples of transmission of power with continuous currents at 1,000 volts. The difficulty does not seem to arise so much from the sparking at the commutator as from the inherent difficulty which is met with everywhere when you begin to apply with continuous currents any high voltage, namely, that of electrolysis of your insulating surfaces or insulating materials that may occur in any place exposed to moisture. We know that electrically caused fires from leaks in mains more often occur with the continuous current than with the alternate, no doubt because the continuous current causes electrolysis in the moisture and the alternating current does not do so; at least not in the same way.

May I point out that in the old fashioned university town of Oxford in England—I must not claim for it that it is a long distance transmission of power, but it is a transmission of power by continuous currents at high voltage. The town is supplied from a lighting station something like a mile and a third—over a mile and a quarter—the current is brought in at something over 1,000 volts, and in the city of Oxford this current is transferred by continuous current transformers, that is to say, motor-dynamos, to the low pressure of 100 volts, and conveyed about the neighborhood from house to house, and that installation has been working now for many months, and gives no trouble. These rotating and continuous current transformers have a very high efficiency, and so far as my information goes, there is no trouble from the spark at the commutators.

Now, let me pass to the alternate current work. I would invite every electrical engineer who is interested in this subject to

study carefully the installation at Rome, which is fed by the power of a water-fall 14 miles away, wheret here is a station erected by the firm of Ganz and Company, of Buda-Pesth, where the water-fall works drive turbines and drive alternate current machines which supply current at from 5,000 or 6,000 volts, carried across 14 miles over the Campagna until you arrive outside the gates of the city of Rome, where there is a transformer station which brings the current down from 5,000 or 6,000 volts, to about 1,000 volts, at which it flows over lines in to the city to be again transformed down to 100 volts for actual use.

I have listened with great pleasure to the discussion originated by Dr. Duncan and carried on so ably by the engineers of the Westinghouse Company upon the question of the polyphase transmission. I have studied that polyphase transmission at Frankfurt, where there were some 8 or 10 different systems, all rivals of one another, from the various houses of Germany. We had the great houses of Schuckert, Siemens and Halske, Lahmeyer and several others, each of them showing their own way of carrying out a polyphase system, and we could compare the one with the other, and it was very interesting to see how they all had solved in their own way that problem to which so much attention has been drawn here, namely, making a rotary transformer convert a continuous current into a simple alternate current. No doubt their rotary transformers will be of service in the industry, but I imagine they will be of service rather in particular instances than in any kind of general way. Let me entirely endorse the remarks of Mr. Frick, that there is no "best" system; that each system is the best for its own purpose. What would you think of an engineer who would stand on the platform here, and say that he had invented or that any man alive had invented, the best steam engine, and that there was no other. You would want to know what that steam engine was best for, whether it was suited for a mill or a threshing machine or a large factory or a steamboat or a locomotive. There is no best steam engine. There is no best dynamo and there is no best motor and there is no best system. They are all right. They are all best.

Well, then, what is the polyphase system capable of and what is the simple alternate system capable of? I am not going to prophecy. I do not know what ten years may bring forth, but I will give you my own personal opinion as to how the thing stands at present. I do not love the complication of three phase transformers and three phase switch-boards and three phase lines. I love the three phase or the two phase alternate current dynamos and motors. They are very beautiful. We can do a great many things with them, but I do not love the complications of switch-boards and transformers. For all distribution systems—distribution, I say, not transmission systems—where you have not only to transmit but to distribute to this and that and the other con-

sumer, I believe you will abandon all the complications of polyphase work and that you will return to simple alternate current methods, and I believe you will find that the bugbears that have been raised, the ghosts that have been put up to frighten you off the simple alternate current system will disappear in practical work, and that the motors can be made as highly efficient and as comfortable with simple alternate currents as with any polyphase system. As I said before, I do not desire to prophecy, but I venture to merely giving you my personal opinion, that the simple alternate current work will be the thing which ten years hence will be found to be effective for all long distance transmission where you want to distribute to a number of consumers.

One final word in conclusion. We in England are trying to get our stations—I am speaking mainly of lighting stations—whether they work by high voltage or low, down to the utmost simplicity of engineering. We shall have one type of engine suitable for its purpose, not half a dozen different scratch lots in the same station, and one type of generator. We have two simple conductors, or at most three, if you are working on a three wire distribution. Everything is tending in the direction of simplicity, and the results are excellent.

If I had come over here expecting to go back to England and say, apparatus has got down to such a beautiful stage of simplicity in the States that you will have to give up everything you have got in the old country and adopt the polyphase system, I should think that I would have been very effectively disillusioned, but the complications of those two diagrams which I see before me, although they represent a most enormous amount of research, of invention, of instruction and of capital fearlessly placed at the disposal of the inventors, are sufficient evidence to my mind of the correctness of my views. I admire what has been done, but while admiring it I cannot help thinking that there is something simpler which will be the successful machine of the future.

Prof. Thompson's remarks were greeted with great applause, and at the conclusion the Chairman introduced Professor George Forbes, F. R. S., of London, who addressed the Section as follows:

PROF. FORBES:—Nothing, Mr. Chairman and gentlemen, could give me greater pleasure than to be told that I am to be limited to five minutes. I have half an hour ago landed from the cars, and I have only just been able to manage to come into the tail end of your discussion. I had expected to arrive early this morning and to be here on time, and I traveled in order to be present at this discussion. I labor under the disadvantage of not having heard the papers read, of not knowing what the subject under discussion is, of only having heard the last part of Professor Thompson's remarks, and being suddenly called upon to address you on the subject under discussion. I know that the subject under discussion is the subject which has been continually occupying my mind for many years back, for which I have been mak-

ing journeys to the United States year after year, and to every part of Europe where I thought work in this direction was being done. It is a work which during the last year and a half has been the incessant occupant of my mind, and not one-quarter of my time, awake and asleep, has been taken away from this subject, and it is impossible to compress into five minutes all the things I would wish to say to you on this subject. Briefly let me take up the points which Professor Thompson was alluding to, and say a few words on some of them.

The first question that arises in this matter is the relative importance of direct and alternating currents. Professor Thompson has wisely said, with regard to the different systems, that each has its own sphere of action. He is perfectly right, and everybody who has gone thoroughly into the question will agree with him. The grandest work in connection with the use of the continuous current for transmission to distances is that which I have seen at Genoa constructed by the *Companie Générale d'Electricité* of Geneva, a representative of which, M. Thury, I believe is present here now. They have done a splendid work in putting that down, working at the high voltage. They have worked even up to 6,000 or 8,000 volts. They are now doing other work in the same direction. The continuous current can be used for transmission to a distance, and in many ways it is extremely convenient, but it has none of the beauty, none of the diverse applications of the alternating current. The trouble which exists in the commutator is a very serious one, and I will not dilate upon it further, as it has often been spoken of. The trouble in insulating the armature is a very serious one, largely because in continuous current machines the armature must be the revolving part. In the alternating current we may have the armature as the fixed part. In that case the armature is just as easy to insulate as the high tension side of a transformer. You may put oil into it if you wish to carry off the heat, but if you trust in any way, and it is dangerous to trust far, to its extra insulating properties, it is perfectly suitable. You may place the wires so that they are not acted upon by the mechanical action of the magnetic field. Professor Thompson has said it is best to connect the generators in series, and you get your best insulation. At the receiving end it is necessary to do the same. You cannot have a 5,000 or 10,000 horse power motor in every work shop and you must put them in series, and the complications are manifold. I will not go further into this question. I have stated the general points and I will now devote the remaining two minutes to another subject.

The great charm and beauty of the alternating current lies in the flexibility introduced by means of the transformers. It is impossible to overrate the advantages of the transformer. A continuous current introducing rotating motor-transformers has no comparison with the simplicity and the practicability of the al-

ternating current transformer. I was pleased to hear Professor Thompson speak about the single phase. The single phase is a great thing at present and has great possibilities in the future. I have had a very long experience of synchronizing alternating machines used as motors, and I have the very highest opinion of them, but they are only applicable in such cases where the motive power is required constantly to be running. For electrical deposition works the synchronous motor is admirably adapted, and also to motor mills, but for all appliances where we have to start, stop and reverse our motors, it is practically out of the question to put in the synchronizing system. I have watched in the work shops of the greatest practical electricians in the world the progress that they have been making in the last three or four years in the evolving of an alternating current motor which shall stop and reverse with facility. Until quite lately there were none of those which were thoroughly suitable and applicable to ordinary lighting circuits. Now, however, we are able to use, as Prof. Thompson has said, a polyphase system for starting the motor, and use it synchronously afterwards, or nearly synchronously. That is a very great advance, and I personally have great hopes that the single phase is going to play a very important part in the future.

On the subject of the best means to adopt, my tongue has been considerably tied in the past, and with regard to the relative advantages of the three phase and two phase systems, on a late occasion, at the convention of the National Electric Light Association at St. Louis, when I was asked to speak, for reasons which were readily appreciated I was not able to speak on that subject. Those reasons no longer exist. I beg to say that as far as I have studied the two, and I have given a great deal of personal and practical study to it, my opinion is that they are both very good, both very excellent; that the three phase is an attractive one from its theoretical beauty, but in practical execution the two phase is better. The reasons why I have a dislike to using the three phase is first the complications caused by having three conductors, all inter-connected. This introduces trouble in regulating the circuit. It introduces troubles in testing and it introduces troubles in correcting a fault which has arisen. I can imagine the perplexity of an ordinary central station attendant when he is told that there is a fault in the line, in his endeavors to find it; if it is a three wire system where that fault is, it increases the labor enormously, but with two phase the wires may be inter-connected or they may be separated. I prefer to have a two phase system with separate independent circuits, and then they are more easily managed and more easily tested and more easily regulated. Moreover, when the three circuits are inter-connected each one has an influence on the other. If you overload one circuit and underload another circuit, the underloaded circuit has a pressure much higher than the overloaded circuit.

That is a fact which is generally known. It is not generally known that if you have three circuits, A, B and C on the three phase system, that if A is overloaded and B and C are not loaded, then B may have a higher voltage than A, but C has a higher voltage than either of them. That is a fact that is not generally known, and has to be known to be appreciated. It is a very serious drawback to the use of the three phase system. For lighting purposes it condemns it. I have advised the officers of the Cataract Construction Company to reject the three phase and to built their first dynamos with two phases, because in so doing my honest conviction is that we are preparing the way to utilize those dynamos in every direction in which alternating current transmission is going to be developed in the next ten years. The two phase system has not only the advantage of being able to work the two phase motors, but it has the enormous advantage that it gives you two single phase circuits. You are able to work each of those with the synchronizing motor and with all the single phase machinery which is going to be invented in the next ten years, and at the same time you have all the advantage of the splendid work which is being done on the two phase system, and I wish that we should be able to have both of these advantages. The dynamos which are going to be put down at Niagara are capable of generating either single phase or two phases. A dynamo so constructed will give you the single phase cheaper than if it were constructed with one circuit; that is to say, there is a larger output with two single phases from one generator than from one single phase circuit from a single phased generator of the same dimensions.

Mr. Chairman and Gentlemen, I feel that I have occupied a little more than five minutes, and in that time it is quite impossible to say one tithe of what I feel is due to the importance of the subject. I have tried briefly to summarize the results which have been arrived at by myself, and which I think all those who have been investigating with the same care have also arrived at.

The Chairman then introduced Mr. C. P. Steinmetz of Lynn, Mass., stating that he would close the discussion.

MR. STEINMETZ:—Mr. Chairman, ladies and gentlemen: We have heard quite a number of able discussions on the different methods of power transmission and distribution. The largest amount of power which is distributed and used in the United States to-day is distributed by continuous current. I am speaking of the hundreds of thousands of horse power used to propel our street cars. That shows that the continuous current is not dead yet, and the very fact that the rotary transformer is recommended as a machine to transform polyphase currents into continuous currents shows that even the advocates of the polyphase current still concede that they cannot get along without the old continuous current.

Now, with regard to the polyphase and the single alternating current, it makes no difference how many phases you use, be-

cause any system of polyphase currents can be transformed into any other system of polyphase currents, by using two transformers only. Furthermore, the motors of the different polyphase systems are essentially the same, worked by the same principles, and the differences which are found are rather mechanical in their nature but not electrical. If I may be permitted to take a look into the future, although we do not know what to-morrow will bring, I think the system of the future will be the single phase system. Where the power is transmitted over a long distance by an overhead wire, the ground can be used as the return conductor. There is no danger to life, because no one would touch a 20,000 volt line, whether it is grounded or not, or if he did he would have no chance to do it again. But if we use a single phase current in the power transmission of the future then we will have to learn many things. We will not be troubled any more with self-induction, with capacity, but proper appliances will eliminate the effect of self-induction and capacity, so that they are entirely annihilated in their effect on the line, and even the loss of energy and resistance will not be carried any more by a less potential. In a continuous, constant current for arc lighting or for any other use, perhaps we are nearer to this ideal condition than we all think.

The Chairman then introduced Dr. Charles A. Pollak, who read the following paper on "The Conversion of Alternating into Continuous Currents," at the close of which the meeting adjourned to August 25, 1893, at 10 A. M.

A NOVEL METHOD OF TRANSFORMING ALTERNATING INTO CONTINUOUS CURRENTS.

BY DR. CHARLES POLLAK.

It is well known that the use of accumulators in central stations has taken a great development in Europe during the last years. Indeed nearly all the central plants in Germany, France and England generating direct current are now provided in the central station itself, or in sub-stations, with storage batteries of comparatively large size working in parallel with the dynamos while the load is at its maximum and supplying the whole current needed in the time of low demand. The technical journals have given ample information about this subject. I desired to show you on this occasion the projections of several central stations which we build in Germany ; unfortunately they were not ready at my departure, and as our mails are not yet run by electricity they arrived only yesterday. The photographs represent batteries of accumulators for 110 volts and our types of 600 and 1200 ampere-hours in central stations built by Schuckert & Co., of Nuremberg, and by the Society of Electric Lighting in Frankfurt-on-the-Main.

The alternating current lighting stations storage batteries have also proved of great usefulness for exciting the magnetic field of generators, the latter giving in these cases far better results as to production of constant tension and regular light than with excitation by means of direct current dynamos. But it has not been possible as yet to secure for alternating machinery a reserve to be disposed of at any time for the supply of current equal to the ever ready storage battery in the direct system, nor to combine with an alternating system sub-stations duly situated and pos-

sessing all the advantages of the direct system, including the supply of current for electro-chemical work and ordinary motors. (Another field is about opening for the employment of stationary accumulators in electric railway plants.) The surplus current necessary at the moments of starting or for overcoming



steep grades is now in many cases supplied by storage batteries placed either in the generating station or near the points of increased demand for current. Owing to the lack of appropriate alternate current motors this sort of current has not as yet any significance for electric railways, though it might give many advantages, especially on long lines such as are now being built,

by applying high tension primaries and line transformers. If there were simple means for directly feeding from transformer sub-stations on the line, the usual continuous current motors and charging auxiliary storage batteries, with or without capacity, a great saving in conducting material and a remarkable increase in safety and simplicity of working would be the result.

All these considerations have led me to the construction of an apparatus for directly transforming alternating into direct currents that requires little cost, little space and little attendance and gives high economical results. I call this transformation *direct* in contrary to the well known method of using a dynamotor consisting of an alternate current motor and a direct current generator on the same axis.

An ordinary commutator held in motion synchronous with an alternating current generator gives birth to a pulsating current of the same direction whose tension varies between zero and a certain maximum given by the generator; it will therefore not be able to drive direct current motors or produce electrolytical effects, to fulfill these purposes, the tension of the pulsating current is to remain above a certain minimum determined by the counter-electromotive force to be overcome in the performance of an electrical work. Herefrom I have drawn the following principles for the construction of the commutator.

The typical commutator of this kind consists of two ranges of insulated strips alternately connected with the generator. The width of the insulation between the strips is in a definite proportion to the width of the strips, which proportion is made adjustable so that the brushes of the commutator will take off only that part of the current whose tension has the proper value.

If now for instance an accumulator battery is to be charged, I will first adjust the proportion between the width of the strips and of their intervals in such a way that the tension of the pulsating current to be taken off by the brushes and led to the battery, may not drop beneath the amount of the counter-electromotive force of the accumulators and the latter be avoided from discharging in the generator circuit. Then I will finish the adjustment of the commutator by a definite displacement of the brushes in order to produce the interruptions of the pulsatory current in those moments when its tension is equal to the counter-electromotive force of the battery in charge and so does entirely away with sparking.

In my first apparatus for laboratory purposes the commutator fixed on the prolonged axis of a small synchronous alternating current motor consisted of two sliding rings insulated from each other and which the alternating current is led to by brushes, and two ranges of strips with converging edges alternately connected to the sliding rings. The brushes sliding on the surface of the strips can be displaced in the ordinary way round the axis and parallel to it. The combination of these two movements allows to fix the necessary minimum tension of the pulsatory current as well as the sparkless taking-off of this current in those moments when its tension is equal to the counter-electromotive force and consequently its intensity zero.

Later on I left the pointed strips in the apparatus for practical use. The edges of the strips are made parallel to the axis and the two ranges of strips fit to be displaced against each other by turning them separately round the axis; besides there are take-off brushes in double number whose distance can also be varied. By combining these two movements I may succeed without any difficulty in quickly attempting the appropriate position as to tension and sparkless working. In this shape the device is cheap, occupies but a small space without foundations and requires little attendance in comparison with a transformer dynamo of the same output. As to attendance in charging accumulators for instance, the adjustment will have to be changed successively at the beginning of a charge during about a quarter of an hour according to the then rapid increase of the tension; then nearly no attention need be given the commutator, the tension rising at a very low rate until the end of the charge approaches and the voltage rise faster necessitating new adjustment of the intervals and brushes; the whole attendance therefore is very simple and takes little time and effort. To reduce the attendance I shall provide the new machines with automatic brush regulators. The first apparatus was built for 80 amperes and has proved to perform the transformation with nearly no loss at all. The measurements have been executed in the following manner. The alternating current was passed through a step-down transformer and the secondary first through a liquid resistance and then through the commutator and battery to be charged in both cases. The number of watts in the primary and secondary circuit of the transformer were measured by means of a wattmeter. The output in the first case was 82,770; in the second 82,670. The motor having

only to overcome the friction of the brushes requires only from 80 to 100 watts with full load, or less than 190 of the whole energy passing through the commutator.

(The small efficiency of only 82 per cent. of the transformers will be easily explained, as I had at my disposal only transformers of older style.)

It might be said that a pulsatory current, as produced by this commutation, was perhaps not good for charging accumulators, but in my experience I did not find any difficulty with it. It may be true that grid or other oxide pasted plates will not stand it, owing to insufficient contact between grid and active mass; in every case the Planté type pure lead plates are preferable for the purpose. (The accumulators used in my experiments, were of my own system.) They have pure lead plates or electrodes, produced by electrolytically depositing porous lead on laminated lead plates, provided with large conducting surface; this artificial increase of surface is effected by previously passing the lead bands through specially designed rollers which impart a great number of ribs. When ready for use, the plates are most solid and may be thrown or bent without harm, the porous lead adhering so fast to the core that no exact limit exists between them anymore. Moreover, the plates are arranged in the cells in such a way as to grant them free extension in either direction by suspending each plate separately on two glass tubes. The charging of these accumulators by means of the alternating current commutated as described above, is performed in quite similar manner and in no more time than with the ordinary direct current. Indeed, the bubbles of hydrogen and oxygen gas escaping at the end of the charge, being usually small with pure lead plates seem to be of still less size when commutated current is employed and give the liquid quite a milky appearance; herefrom it may be inferred that the destructive effects the bubbles sometimes produce upon the porous surface layers by mechanical action in cases of over-charging or exceeding charging intensity are of lower influence on the durability of the plates than even with common direct current.

The kindness and courtesy of several American gentlemen, and especially of the General Electric Company, for which I express here my best thanks, enables me to show to those who are especially interested in this matter, the machine just described,

in the World's Fair Electrical Building, German Section, at 5 o'clock to-morrow.

FOURTH AND FINAL MEETING, FRIDAY, AUGUST 25, 1893.

Section C was called to order by the Chairman, Prof. Edwin J. Houston, at 10 o'clock,

On motion of Lieutenant Hasson, it was

Resolved, That the Secretary of this Section be instructed to draw up a letter of thanks to Lieutenant Spencer, of the General Electric Company, in acknowledgement of the many courtesies extended by him to members of the Congress.

The Chairman announced that before passing to the discussion on Power Transmission continued from the preceding day Mr. Frick desired to make a few remarks on Dr. Pollak's paper. Mr. Frick spoke as follows:

MR. FRICK:—The apparatus described by Mr. Pollak is of very great importance; I will not say for this country to-day, but it may be in the future. I do not think it impossible that in a few years you will have in this country accumulators, and then you will see the great importance of having apparatus that transforms alternating currents into direct currents in an easy and cheap manner. In Europe, as you know, accumulators are in very excessive use, and I think they are used in America, although the central stations do not use them. In the winter the disadvantage in this country at stations is very great. You must furnish all the currents by machines, and one horse-power delivered by machines is about 40 per cent. dearer than the one horse power given out by accumulators, on the supposition that accumulators and machines are to be placed in the same room in the same station. Now, in Germany we have tried a system of distribution with small accumulating stations distributed in the town, but the stations have as yet not been as successful as the direct distribution system, and I would like to say that the reason for that has in great part been the great cost of the alternate-direct current transformer. You want to transmit power from the central station to the different sub-stations in the cheapest manner, which I am sure is by the use of an alternating current of high potential. To change the alternating current into a direct current, we had heretofore no other device than to take an alternating current motor and couple it with a direct current dynamo. This device is a very expensive one. If you take now this apparatus devised by Mr. Pollak, it is a very cheap one, it costs hardly anything, and a second point of very great importance is that the ordinary motor transformer to convert alternating into direct current has a very bad loss. Mr. Pollak's transformer does not lose more than three or four per cent. and

thus there is a gain of 10 or 15 per cent. For the purpose of demonstrating to you what will be saved, I have brought with me some plans that we have made for the city of Frankfurt. As the whole city was to be lighted we wanted to know definitely what was the best system for it and we drew up a great many plans. We had first an alternating current system with primary and secondary net works; second, we had a great number of accumulator stations charged at 200 volts; and finally the system of alternating direct current transformers; and to tell you the result I will say that the simple alternating current was by far the best. The alternate direct current transformer system could not be used because it cost too much for the transformers, and there was also great loss in it. This great loss and great cost made it impossible to accept this plan, and hence you see the importance of this invention of Mr. Pollak, because his apparatus costs very little, whereas these motor dynamo transformers cost about 730,000 marks. If you take away this great expense you will have about the same cost as for the ordinary alternating current system. I wish to point out to you that in the future this matter may become of some importance in America also. In Europe they are using a great many accumulators, and all the people that use them are well satisfied with them.

THE CHAIRMAN:—I will now call upon Professor George Forbes to re-open the discussion on Multiphase Motors and the Transmission of Power. It was quite unfair to limit Professor Forbes to the very short time that we did yesterday, I did not know at the time that the Professor had arrived at the end of a very tiring journey. He is now in better condition to speak and I take pleasure in extending to him all the time he needs.

PROFESSOR FORBES:—Mr. Chairman and gentlemen: I read in the morning papers that there has been an organized conspiracy among the American engineers, led by no less a man than our esteemed friend, Dr. Duncan, to "draw" the foreign engineers on the subject of the transmission of power and multiphase motors. Now, in the first place, I presume that has no reference to me. I must say from the relationships which I have had with every one over here, I hardly look upon myself as a foreign engineer, but even if such an attempt has been made to "draw" the foreign engineers out, I do not see what the object of it was. I do not see that they need any drawing out. They are only too glad to enter into the discussion of the things which are of mutual benefit to everybody.

Your Chairman has been good enough to ask me to commence this discussion with some further remarks on the transmission of power and on the use of alternating currents and multiphase motors. I feel that before such an assembly it is a very fitting time that one should say a few words about one of the great works on which I myself have been engaged, and the history of the progress in connection with that work and the condition of

affairs at the present moment in the way of utilizing the Falls of Niagara. A great deal of time and thought has been given to selecting the best system to be adopted for this work, and for a long time the question was open whether the power should be used directly by wheel pits communicating with each separate mill that was going to take the power. It was a resolution of the deepest importance which was arrived at by the President of the Cataract Construction Company when, after having inspected all that was being done in Europe and knowing all that was being done in America in the way of transmission of power, he telegraphed to the New York office that it must be decided to start central stations at the Falls of Niagara. That was the first step that was taken. The question then was whether the power should be transmitted to the work shops requiring power by compressed air, by rope transmission or by electricity, and I may say that for a long time there was a great preponderance of opinion in favor of compressed air. Finally we have all to congratulate ourselves that the resolution was adopted to do the whole of the transmission by means of electricity.

In the year 1890 a number of plans were invited from different engineers and manufacturing firms as to the best means of utilizing this power. These plans were submitted before an international congress consisting of members well known in the engineering and electrical world of all countries, who met in London at the beginning of 1891. At that time one report used these words: "It will be somewhat surprising to engineers in general as it was to myself to find that the only possible means of transmitting this power to Buffalo and the best means for using it in the neighborhood of the Falls is by means of the alternating current." I made that statement in my report after having considered carefully every means which was then available. I have never had any reason to change my opinion from the year 1890 to the present day. I proposed then that the work should be done by alternating currents generated in two phases; that these should be sent along separate circuits at high voltage; that transformers should be used for reducing the pressure down and introducing a safe pressure into the work shops; that in the work shops synchronizing alternating motors should be used in most cases, and that in other cases two phase motors should be employed, and that in the cases where the direct current was necessary, alternate current motors should be used to drive continuous current dynamo machines. That was in the year 1890 and in the present year, 1893, there is hardly a change to be made upon that system which was then proposed. In the interval of that time, however, we have been only too anxious to hear all that could be said in favor of every different system, and I myself have felt a perfectly open mind in the matter since my having expressed an opinion in 1890; in fact, I would not have had the least shame, in view of the rapid progress as made during those three years, in

changing my views entirely, and to have said that the continuous current was the best for the purpose, but we studied the question very thoroughly. At the time when that international congress was held, there was desire among the members of the commission to pass a resolution which was to be transmitted to the Cataract Construction Company informing them that the alternating current could not be used for the purpose. At the present moment every single member of that commission has changed his views, except perhaps one and I must say that electricians can congratulate themselves on this in the present state of the art of transmission of power, that whenever a definite problem is brought forward, I notice that if half a dozen able electricians consider the question independently and without personal interests to consult, they are generally very close in accordance in the methods which they advise for adoption. You cannot say that one system is always the best, and undoubtedly each system has times when it ought to be used, but in any one scheme I am bound to say that from what I have seen most engineers will agree if they have got data placed before them.

I mentioned yesterday the chief considerations objectionable in the use of continuous currents for the transmission of power at Niagara Falls. There are many cases where the continuous current is the most desirable to use for transmission of power, and the chief disadvantage is the necessity of putting all your motors in series at the receiving end of the line. But in all these cases that come before the practical engineer, the most important thing to consider is the question of cost. At every stage of the working out of the scheme the cost is really the thing that governs the engineer most of all, and it is fortunate when we find that the best harmonizes with the cheapest, as sometimes happens in great engineering works, and, as I am glad to say, it has happened in the case of this great work of the utilization of Niagara Falls. After the congress closed its labors and when electricity was decided upon for the purpose, projects were asked for from many of the greatest firms in the world. They were asked to submit plans for dealing with this problem. Some proposed continuous currents and some alternating currents. The greatest difficulty was experienced in nearly every case by those who were proposing continuous currents to meet the requirements in any way whatever, and in every case the cost was largely in excess of the cost with alternating currents.

One of the things which we have decided upon is that we are to use the same system for the distant transmission as we are to use for the nearby transmission. Nearly every person, when they have begun to tackle this problem, have thought that it was desirable to use a lower voltage for the nearby transmission. One or two thousand volts seemed to be considered right when you were only transmitting a distance of a mile or two, whereas 10,000 or 20,000 volts was considered nearer right for the distant transmission,

but the advantages which we gain by using the higher pressure to a great distance are also gained in using the nearby distribution. Moreover, in all these cases it is almost impossible to grasp the full conditions of the problem until you come down to drawing out the details. Suppose you do start with 1,000 volts for a distribution say of the first 50,000 horse power in the neighborhood of the Falls, you will find that the mass of conductors that you have to deal with is something simply impossible. The most convincing argument that I was able to adduce on this point was by drawing a full scale section of a subway carrying the conductors which would be necessary at 50,000 horse power, and it filled a large subway through which a man could walk. It filled that subway up with conductors in such a way as to show, without any further demonstration, that it was unpractical. Moreover, the simplicity of having the whole of the system all in one voltage is something which cannot be overestimated, and this is the way in which we propose to work.

I am glad to feel that the universal opinion is now in favor of the adoption of alternating currents. I can only quote one man of any eminence who seriously and persistently considers that it is the greatest mistake to use the alternating current for such a purpose. I will not mention that gentleman's name, and it is a very well known name, one that bears the greatest influence; so great that I and those with whom I have been associated have considered with the utmost care every single point in the matter before rejecting the advice that has been given us. The opinion was stated in a general way, but the concrete way in which it was stated by this authority was on the top of our vertical shafts which come from the 5,000 H. P. turbines we should have a building four stories high, for each turbine. Each floor should be insulated completely from the rest of the building. At each floor there should be a large toothed wheel driving five other toothed wheels, by a special geared improved design on each one of which should be a dynamo on a vertical axis. We should thus have 20 dynamos, each 1,000 volts, all continuous current dynamos, all connected in series. That plan we have considered most carefully, owing to the source from which it came, and we have rejected it for present purposes. We are now going ahead with the alternating current, and at every point the question of cost has been considered, and the results which we have arrived at I believe are the best, and I may also say that they are certainly the most economical.

In the year 1890, at the time that I proposed the adoption of synchronizing alternators in some cases and Tesla motors in other cases, there were comparatively few who had much experience of either one or other of these alternating motors. The Tesla motors I had fortunately been able to see at the Pittsburg works of the Westinghouse Company, and they have been placed at my disposal for experiments, and I put a high value on the outcome

of these motors and what they would be developed into. I regret to say that during the intervening years there was very little done in the way of developing these Tesla motors at Pittsburg, but in the mean time the question was being taken up in other countries, and in Europe at the time of the Frankfurt exhibition in 1891 there was a great deal of multiphase work shown in action. This directed the attention of the world to it, and I am glad to say now in America also the multiphase motors have made more progress. Professor Silvanus P. Thompson yesterday said that he thought multiphase motors would disappear from general distribution, and that the single phase motors with a multiphase means of starting the motor might be the more universal way adopted. That is one of the possibilities of the future. There are several possibilities of the future that we must consider in any very great scheme like that which I am speaking of at the present moment, but in the mean time we must deal with the possibilities of the present. I consider that the multiphase motors at the present moment are not only a possibility, but are a valuable adjunct to other uses for which the alternating current can be used. Now, a great part of the work in any large system of distribution like that is the continuous working, day and night, or from early morning till late at night. A mill is started in the morning and never needs to be shut off during the day, and then there are other mills of a character most likely to be attracted to such a situation who run day and night, from week's end to week's end. The largest consumers of power which we have at present are the pulp mills for making wood pulp for paper, consuming thousands of horse power, and next to these come the electric deposition works where power is required from week's end to week's end continuously running. In these cases, if it is simply power you require, a synchronous motor is admirably adapted and thoroughly satisfactory, but in all ordinary work-shop practice where we wish to be stopping, starting and reversing our machinery, the most convenient alternating motor, which is a thing, not of the future, but ready for practical use at the present moment, is the multiphase motor. It is possible to do without the multiphase motor perfectly well, but it is a valuable adjunct at the present moment.

I will speak of a few other possibilities which are immediately before us and within our sight at the present moment, and which there can be little doubt will be available to us in the course of the next few years, but which it would be unwise entirely to depend upon at the present moment. Among these it will be said that I am very careful, perhaps, if I include those commutating or rectifying machines which have been given the name of rotating transformer; a misleading term, because it implies that the machine transforms the pressure in any required pressure, but machines which commutate or rectify the alternating current into the continuous current by the rotation of the

armature, and this machine was first largely shown to the world at Frankfurt in 1891, and chiefly by the firm of Schuckert & Co., and has been largely introduced in America for experimental purposes, at any rate, and to show how thoroughly convenient they are, and there are several specimens of them at the World's Fair. These machines involve the rotation of a full sized armature with all the losses involved in the armature of a dynamo machine, and consequently they add to the general losses of the system a loss of some, let us say 10 or 15 per cent. This loss is undesirable. Remember that the sole function of these machines is to commutate or rectify the current, and it does seem to me as if the world is sufficiently advanced in the applications of electricity to be able to devise a commutating machine which shall simply do the act of commutating a current without this great loss of power. A great many attempts have been made in this direction. It is a very desirable aim, in order that we may have machines at a distance from our generating station to work our street railways, which at present are worked by continuous current, and for other purposes. If we carry our high tension alternating current to a distance, to Buffalo, to Rochester, to Utica, Syracuse, Albany, to transform it down to a low pressure and then commutate it by a simple commutator that is not absorbing power to an appreciable extent, we have a valuable adjunct to our machinery. This is one of the possibilities which is almost certain to arrive in the course of the next few years, and which we must look forward to and not leave out of account.

Mr. Pollak has this morning shown us an extremely valuable and simple way of doing this. As to the successful operation of it in practice, many of us have still to learn a great deal, and I am sure that each one of us who is interested in the transmission of power to a distance will take advantage of the offer which has been made to us to inspect his machinery at the World's Fair. Other attempts have been made in the same direction by Hutin and Le Blanc in Paris, and Ferranti in London, and by various other inventors, but I may say that a commutator of a simple kind, not losing over 10 per cent., is a thing which is going to come, and we must look forward to it, although we cannot depend upon the possibilities of the future in the organization of our schemes of the present.

Other things are likewise coming. You have heard of the numerous attempts that have been made to devise single phase alternating current motors which can be put upon our lighting circuits. These have hitherto been not an entire success so far as they have been actually put upon the lighting circuits. We have seen, however, lately in Switzerland the successful construction of such a motor which can be put even on such circuits as are ordinarily used for lighting purposes, and this even when the frequency of alternations amounts to 135 periods per second, as is very generally used in this country. Such motors have been

produced which work efficiently on those circuits, but there are a large number of motors, which, although not quite successful on this high frequency, at some lower frequencies are very efficient and satisfactory. I need not mention the names of all the inventors who have been at work in this direction, for they are countless, and I have seen myself with my own eyes and worked with my own hands machines of this class of a great number of different types, all capable of doing good work on a rather lower frequency than what has been used with the lighting circuits in this country.

By the by, there is also a type of machine which I proposed for adoption, as a possibility in the future, with alternating currents, in the year 1883, and that is the direct current motor with a laminated field, and that also has a certain amount of possibility in the future; at any rate, with lower frequency than what we have been using. There are some difficulties in its use, but such men as Eickemeyer, Professor Anthony, Tesla and various other gentlemen have been engaged upon work in this direction and it has promise for the future.

Now, another of these things which are promising for the future is the question of arc lighting. At the present moment we could use alternate currents for arc lighting. It is being used for that purpose in Europe; it is being very largely used in some places. At the present moment in this country it has not been so very largely used for the arc lighting, and most of us are of the opinion that the continuous current arc lamp is a more successful thing than the alternating current arc lamp. In the first stations which have to be supplied from Niagara Falls for the purposes of either traction or arc lighting, there are existing companies at present doing that work. They have got steam engines driving their dynamos, generating currents for these street railways and for these arc lamps. What they want us to do first is to throw out the steam engines, put in motors to drive these dynamos which they have there, not to throw away their whole plant; therefore these at present come under the consideration of the power stations which have to be supplied. But we shall have to deal with arc light systems, and if we can get the direct current easily and satisfactorily from the alternating current, it is a very desirable thing to aim at. This, gentlemen, is one of the possibilities of the future.

Mr. Ferranti has been working during the last year in developing a combination of a transformer and a simple commutator which shall convert the alternating current into the continuous current, whose value is constant, a current of 10 amperes or 15 amperes or whatever we may fix upon, and this commutator of his is not one of those commutating engines which we have seen here, but it is simply a commutator which is not absorbing power to a large extent in an armature like the other machines. It is a simple commutator and it is working well, and I have the greatest hopes that that may be developed in the near future.

While telling you what we are doing at Niagara Falls, I have only felt that it was right that I should put before you these possibilities of the future, because it is only right that we should consider most carefully what developments are likely to take place in the next few years, and we ought to provide that the machinery which we put down shall never be obsolete. In the meantime, for reasons which I mentioned to you yesterday, we saw a decided preference among the different systems of polyphase transmission and transformers in favor of a system in which the lines are not inter-connected. That system when most simply produced is the two phase system with two independent circuits, one for each phase. We are going to have dynamos made in two phases, not only because we want to avail ourselves of developments in this line of working that manufacturers can offer us, but also because we get our single phase circuits cheaper than if we built the machine with one phase instead of two phases. If we use only single phase motors we get a larger output from the same generator by building it of two phases than building with one phase. This was appreciated as early as 1879 by a man whose name we all honor so much in connection with development of electrical work, M. Gramme. M. Gramme's first alternating current dynamos were in two phases, eight poles and two phases with a revolving field and fixed armature.

As to the motors which we shall be using, we shall be using synchronizing motors of single phase, polyphase motors, and sometimes, no doubt, converting into continuous current and using continuous current for street railways.

The paper of Mr. Pollak which was read yesterday and which has been referred to involves what I consider the most important point for electrical engineers to attend to that can be thought of at the present moment, the commutating or rectifying of the alternating current to give us a continuous current. All direct current dynamos except the unipolar ones are the combination of an alternator and a commutator, and every advocate of the continuous current that there ever has been, and there are bigoted advocates, would have been convinced in favor of the alternating current dynamo, alternating current and transmission, if you could have told him that you would put a commutator at the far end of the line instead of at the place where you generated your current. That is the proper place to put a commutator if you are going to put one anywhere at all.

There were a good many special features in connection with the Niagara projects which rendered special features in the design of a dynamo desirable, and which naturally will differentiate the dynamo which is to be used there from those which have been in more ordinary practice, but I venture to say that there will be no serious departure in the dynamos which are put down from the ordinary lines which we have found to be perfectly satisfactory in the past. One of the features is that we

have a vertical shaft instead of a horizontal shaft. As you are all aware, the water of the Niagara river is taken off one mile above the Falls by a large canal which has been built. It is then taken by channels into the wheel pits and falls through iron pen stocks to a depth of 140 feet to the turbines below. These turbines have been designed by the illustrious firm of Faesch & Picard in Geneva, and have been constructed by the I. P. Morris Co., in Philadelphia, and will be delivered very shortly. They revolve at 250 revolutions per minute. The water, after passing through the turbines, is carried down through the great tunnel which has been built and which is an engineering work to be proud of. On the top of the turbines is a vertical shaft coming to the surface of the ground, and that shaft rotating at 250 revolutions a minute causes the large dynamos to revolve directly on the same shaft without any gearing whatever at the same speed.

It has been proposed in many cases to generate the current at low voltage and use a step up transformer to create a higher voltage. There are two objections to this. The first is that we have the cost of the transformer. The second is that we have the extra losses in the transformer. If it is possible to create the whole voltage that we require in the dynamo instead of in a transformer, we save the cost of a transformer, which is approximately, roughly speaking, about the cost of the dynamo, and we are saving some three per cent. of efficiency. Now, three per cent. of efficiency! I do not know if every man realizes that until he begins to count up what it is. It means 150 horse power in each of our units. Our units are 5,000 horse power. Three per cent. of efficiency saved would be 150 horse power. That seems so much more earning capacity to our plant, our tunnel, canal, wheel pits, dynamos, and works generally. That means so much more rental to be taken in. Suppose you put that at \$20 per h. p. per annum, and 150 horse power, that is, \$3,000 per annum is saved by saving that little three per cent. \$3,000 per annum capitalized at five per cent. would be \$60,000. By saving that three per cent. you save more than the whole generator and the apparatus in the station connected with its work, the dynamo and the whole thing. When we reduce these things down to figures we see what value a high efficiency is to us. Now, I maintain that by following the example set by Gramme, of having the armature fixed, it may be a little extra expense but nothing like the expense of putting in an extra transformer. You can build that dynamo to the same voltage that you are going to use with a transformer. The fixed armature becomes a thing as easy to handle and as safe to handle as the transformer itself, and you can introduce your very high pressure into that armature with the same safety that you can introduce it into the transformer.

Now, I will not say more about the general arrangement. I think I have said enough for the present, and I felt that it was

only right to say this much before so distinguished a congress at this particular stage of the work. I will say one or two words, if the Chairman will allow me, on the question of the means of transmission.

It has been an anxious consideration as to whether the transmission ought to take place by overhead conductors or by means of a subway; also the question of laying underground cables has been considered, in a conduit. I distinguish, gentlemen, between a subway and a conduit thus: I consider that a conduit is a place for putting cables in. I consider that a subway is a place for putting in conductors, and where a man can walk along and inspect them. Obviously the most complete and satisfactory method would be to put a subway wherever you want to carry these high tension mains, and the cheapest way is obviously to put a pole line all the distance, and the intermediate way is to put a conduit of cables underground. (Other plans may of course be suggested.) The intermediate way is, as often happens when we try to strike a mean course, disastrous. One of the greatest troubles which is likely to come to this work, unless it is watched against with the greatest care, are the troubles arising from the capacity of the line. It was said of the high tension transmission at 10,000 volts between Deptford and London, which was for so long a time an experiment, that there were two things to consider in connection with the cables: first, their capacity, and secondly, their incapacity. Their latter defect has, I am glad to say, according to the latest advices, disappeared entirely, from knowledge acquired as to how to deal with the first defect. Now that the capacity of these cables is handled in a proper manner, in a scientific way, there is no trouble. But capacity is always apt to lead to trouble and ought to be avoided in this case in the cables, and for that reason, if for none other, it is undesirable to have insulated cables acting in this manner; consequently the work will be done either by overhead conductors, bare wires, or by bare wires carried in a subway. Naturally, the cost of a subway to Buffalo is a very serious thing. The first place which we have to supply with power is the Pittsburg Reduction Company in the manufacture of their aluminium, which is at a distance of 2,500 feet from the power house, and we have also to proceed almost immediately to Buffalo. Later on we have to meet the agreements which have been made to supply places situated along the Erie Canal, and since the State of New York has taken up experiments on the possibility of having their towage on the Erie Canal conducted by means of electricity, we have to consider the question of transmitting electricity over the whole of that distance. I may express as a purely personal opinion, that the action of the State of New York in this direction is an action of the very highest importance; that it is likely to revolutionize traffic in the State of New York; that the volume of transportation over the Erie Canal will be such as to benefit manufacturers

in all parts of the State, and more especially those in the neighborhood of Buffalo and the Falls. This work takes us ultimately to a distance of 350 miles. This involves high electric pressures and it involves the consideration of the expense of laying our line.

I have lately had occasion to deal with a similar problem in India. The India Government has lately been irrigating the eastern side of the Nilgharry mountains by means of the rivers on the western side of these hills, and driving a tunnel through the mountains to carry water to irrigate land. They found that when the water was carried through the tunnel it was at an elevation of 1,200 feet, within a mile and a half, above the place where they wanted to begin to use that water for irrigating purposes, and they had sufficient water to develop 50,000 horse power. They have been considering the question of generating electricity and I have had to look into the electrical question for them. In that case the greatest development of electrical power and lighting would be at the town of Madras, which is 350 miles from this place, but still, according to the best information that we are able to collect on what has been done at high voltage, it seems almost certain that this power can be carried that distance and delivered at Madras as one of the cheapest forms of power in the world, because all the hydraulic works are already created and their sluice gates and everything prepared, and they are simply putting in the transmission plant.

The transmission from Niagara Falls to Albany is almost identical with this. The distance is the same, and when we come to supply this canal we shall have to consider the question whether overhead poles are possible. In the mean time it will be desirable to have some experiments made upon overhead construction, but in this climate there are very great difficulties. The two most serious difficulties that have to be contended with in connection with transmission for an overhead line are first, those due to lightning, and second, those due to sleet. The sleet trouble is a very serious one, especially in the northern climate. Broadly speaking, the conclusion which it seems we must arrive at is, that a transmission by overhead conductors must, in the nature of things in that climate be liable to occasional interruptions, and that the electrical subway is almost certain to be carried out without interruptions, giving a continuous service. This makes one naturally favor the subway system. But experiments will be carried out with the polyphase system undoubtedly, and I have to conclude by making one statement which I think ought to be a matter of congratulation to all of us who are interested in seeing such a scheme successful, and that is that a subway, at any rate part of the way, has been begun. Last Friday the first sod was turned for a subway which is going to carry the conductors from the power station at least so far as the Pittsburg Reduction works, which is half a mile distant from the power house.

The Chairman then called on Prof. H. A. Rowland of Baltimore to continue the discussion.

PROF. ROWLAND:—Mr. Chairman and gentlemen: My first appearance in this Congress was in the section of Pure Science, and we had arranged the papers, we thought, so that the questions of pure science came in that section. Well, I have wandered along until I got to the section of Pure Practice, and I stepped in, and instead of finding practice, discussed, I find a paper which ought to have been in the section of Pure Science, because, as far as I can see, the whole subject is one of pure theory as to the transmission of power. During the time I have been here I have only heard pure theory discussed. I have not been here during the whole of this discussion, and can therefore only make a very few remarks.

In the first place, with regard to whether the dynamo should be arranged for small potential or large. Suppose you wish to get 20,000 or 30,000 volts, or even 10,000, is it the better to use a transformer or to have dynamos giving the 20,000 volts? We have just heard a calculation on this subject which intimated that the use of a transformer for a 5,000 horse power dynamo would be equivalent to losing the interest on a capital of \$60,000. Well, what is that based upon? Practically, that it is 150 horse power that you lose, but where does that 150 horse power come from? It comes from a turbine, from water. Water is plentiful at Niagara Falls, and if they turn on a little more of it they would not lose an amount of \$3,000 a year. I certainly would dispute that statement. The only case in which the 150 horse power would come in, would be when you were using the turbine up to its maximum efficiency. How often would this happen? All electricians know, even I know, the pure theorist, that only once in a day, once or twice in a day do we use the turbine up to its full power, and as to getting an extra \$3,000 out of this 150 horse power, why, I would very much dispute it. In regard to high voltage dynamos I may say that I have seen the sparks go through a thick cap of rubber over the magnets. I think the potential was only 5,000 volts, although it may have been 10,000, and as to building a dynamo above 5,000 horse power, I think all who have knowledge of the matter would agree that there is a great difficulty in it.

Now, as to the transformer, that is quite a different affair. How do we make a transformer to stand the 10,000 volts? Why, we do not insulate the wire for 10,000 volts. We build it up so that the first section shall give 1,000, the second section, 1,000, and so on until we get 10,000 or 30,000 volts, so it is a perfectly easy matter to build the transformer for 100,000 volts in this way and only insulate it at any one point for 1,000 volts. But that is quite a different affair when you come to treat of a dynamo. What is the one fact on which the value of a dynamo depends? Why, it is the amount of copper that you get

in the slot. If you have slots in the armature it is the amount of copper you can get in them compared with the size of them. As you go up in potential this amount becomes less and less on account of the amount of insulation required. If you have a very high potential dynamo the quantity decreases until it is only very small indeed. It might be for low potentials 50 per cent. or even a little higher, but for very high potentials it becomes less and less until the dynamo is worthless. Therefore, for these reasons I think that it is the common practice to build dynamos for very small voltage if possible. As far as I have talked with practical men on this subject it seems to me they all agree upon this point, and I therefore think that instead of \$3,000 a year being saved by the use of the dynamo without transformers, that you would lose much more than that in burning out, repairing, and everything of that sort.

I have not heard anything said about the period of the current—the frequency. Now, of course in power transmission that is the most important thing; that is a fundamental point to be decided first, what shall be the frequency?—in alternating circuits, of course. Now, what is the effect of frequency? We all know when we have a high frequency what happens. You get into all sorts of difficulties which you obviate by making it less and less. Now, is there any lower limit, for the higher limit is perhaps less desirable. A lower limit, I believe, has never been studied. The lower down you go, the only effect that most persons observe is that the transformers have to be made larger. That seems to be the only effect which is mentioned, although it is known very well that a frequency of 40 or 50 will blot out the arc lights. A frequency of 30 makes incandescent lighting barely possible. When you get down below that we could have nothing but power transmission alone. Now, shall we keep on down to four or five, and finally down to one per second, and then we pass into continuous current. Where shall we stop? Now, of course if we do not stop at the 30 or 40 which would allow a little lighting to be done, then the only thing to be considered is the power transmission. Now, what would be the effect of building a motor or dynamo for four per second? Well, in the first place the effect of lower frequency is a diminished number of stoppages to the magnets in the dynamo. That is very well, of course, and finally we get down to such a small number that we cannot reduce it any more, and then we have to slow up the machine, so of course that is one of the limits, when we have to run the dynamo with such a small speed that its output is less than we wish, and then we have to increase the speed. But suppose that that condition does not apply. Suppose the dynamos are already going very slow, so that we can get a frequency of four or five per second. How does the dynamo run under those circumstances? If it is a two-phased machine, it runs pretty well with the same amount of power taken off of the two

circuits, because they balance each other pretty well and make the motion of the dynamo pretty even; but if you should use one of the circuits more than the other, or throw out one entirely so as to have a single phase dynamo, then you will, of course, get a tremor. If the frequency was four a second, there would be a tremor of 16 times a second, and this is so great under some circumstances that it may produce a very great vibration of the machine. Now, of course this applies to the motor as well as to the dynamo. The motors will have this vibration also, and the laws of it are easily obtained. As I remember it, the frequency is inversely as the square of the tremor, so that for a period of four and of eight the vibration would be in one case four times the other; that is, the square, I think, of the ratio, so that you do not observe this at all when you get up to 30 or 40 per second, the dynamo is apparently perfectly smooth in its action, as well as the motor. Synchronizing motors of single phase cannot be used at very low frequency without this trouble.

Then take the case of the transformer with low frequency. They will have to be increased in size, of course. I think the ratio in size is something like inversely as the frequency, so that with 10 periods per second they would be five times as large as with 50 per second. That is true, provided you keep the magnetization constant, but as the number of alternations become smaller, you can increase the magnetization in the transformer, but how much can you increase it? Well, as you decrease the frequency and increase the magnetization, the current curves and the curves of electromotive force become distorted, as to how much they become distorted depends upon the resistances in the circuit, and all that, and you cannot tell except in each special case, and that you can calculate, or better still, you can experiment upon it and find out how much you can raise the magnetization, but there is a limit of some kind, so that the transformers certainly have to be made considerably larger at low frequencies than at high. Therefore, there is a lower limit of the frequency which you can use. As to what this is, I will not express any opinion, except to say that if you wish to have motors running at 1,000 turns per minute, I think the number of periods must be about 20 or more. As you go down, the effect is also to make the motors run more slowly, and therefore the output of the motors will be less than before, and you have to fix upon the velocity with which your motors will go, and then the frequency is determined by that. Therefore you have a lower limit to the frequency as well as a higher one, and the question would be, of course, in any practical case, where one should draw the line. I have a paper in the other section on the harmonics in the circuit, which also will have some bearing upon this subject, but I will not bring that paper before you now, but stop with these very few remarks.

THE CHAIRMAN:—I will now call upon Prof. D. C. Jackson, of the University of Wisconsin, to continue the discussion.

PROF. JACKSON :—Gentlemen : In the discussion at the meeting yesterday, we seemed to have stuck very closely to the question of transmission of power over comparatively short distances. This morning we have gone on to what may be called really long distance transmission of power. The transmission of power over comparatively short distances we are all acquainted with. We have been referred to plants in Switzerland, Italy, France, Germany, and other European countries. If we study these plants, we cannot but be struck by the solidity of the construction and design, and the successful operation with which their projectors have enabled them to do their work. However, with all due deference to the designers of Europe, especially M. Thury, who is with us or was with us yesterday, I would say that plants in which the transmission of equal or even greater powers to equal distances and possibly greater distances than those found in most of the plants referred to yesterday, can be found even in our American cities. Taking Chicago alone for an instance, there are motors on circuits in Chicago up to over 100 horse power in capacity each. The largest motor in Chicago has a capacity of more than 100 horse power, and while these motors are all within the city limits, I can assure you that it is some distance from the station to the motors. I do not, however, consider that this is really long distance transmission. The transmission of power can be divided roughly, (and you must remember when we make divisions we make them merely as rough guides to our minds, because all divisions overlap) into three divisions; first, the distribution directly from a central station; second, the transmission of power from a station to motors in a single shop; and third, the long distance transmission of power with distribution from the other end of the transmission and the plan that is apparently bound to come into prominence all over the world I may say will be the transmission and distribution plant. In connection with that plan a third one will be the direct distribution also, as it was so ably set forth by Professor Forbes in connection with the transmission and distribution plan; also the distribution directly from the station and the carrying on of the distribution from transmission stations at the various radii. The discussion of this latter plan is quite theoretical. We have been referred to the plant at Rome where the alternating current is used. We can refer to plants in this country, two or three of them, possibly, in which the distance of transmission varies from 10 miles up to 30 miles, and these plants have all been successful. They have been successful as transmission plants and fairly successful as distribution plants. But, gentlemen, in a matter of this kind we cannot take our ideas from one or two small plants. Either we must have before us one great plant or else a great many smaller ones, and until the larger plant is actually in operation, or many small transmission and distribution plants are actually in operation, I fear that we will

simply theorize and theorize, and we will not be able to get down to pure practice. I trust with the help of the consulting engineers that we have here and manufacturers, that in the next two or three years we will be able to know where we stand in transmission and distribution of power, but at the present time, while our practice is fairly outlined in simple distribution, in simple transmission, it certainly is not outlined, nor do I believe it can be outlined for two or three years more, until we have more experiences in long distance transmission and distribution of power. That is all I will say this morning, on account of the inflexible five minute rule.

THE CHAIRMAN:—Dr. Louis Bell has some remarks to make, a few remarks in addition to what he said yesterday, and will now continue the discussion.

DR. BELL:—Mr. Chairman and Gentlemen: The discussion this morning has taken a turn that is very interesting to me, in raising questions which reach much further than the discussion of yesterday would have suggested, particularly of the questions of high voltages and long distance transmission. The first thing, however, which I would like to mention is apropos of the discussion of yesterday, where some experimental data bearing on the theories advanced may not be unwelcome. In the first place, Dr. Duncan very pertinently raised the question of the effect of the wave shape on the operation of two field motors, whether single or polyphase, stating that very great and very unpleasant effects could be produced in case the wave given by the machine were not a sine wave. I can experimentally assure Dr. Duncan that such is not the case, but only under rather extreme conditions. Careful experiments made with the same motor driven from two generators, one of them specially arranged to give the wide variations from the sine wave, showed that the sine wave current gave a higher efficiency for the motor of perhaps two per cent, a perceptible amount and yet a small one, so that I am inclined to think that in practice the effect on the efficiency alone is not likely to be very great with any machines that we are likely to have designed for long distance work.

The question was raised yesterday with some pertinence as to the regulation of the inter-connected circuit polyphase system. In this respect I can only appeal to experimental data as against any cases which could be figured out under special conditions. As an experimental fact it is quite easy to regulate a tri-phase inter-dependent circuit system so as to fulfill easily all the requirements of commercial distribution. It is possible by arranging any system badly to get bad results, and there may be arrangements of transformers and arrangements of systems that will give bad results, but with a properly designed tri-phase system the regulation is well within commercial limits; and variations such as have been mentioned by Professor Forbes, although they do exist, are of a magnitude that is not of the slightest con-

sequence in a practical case, because we never expected three-quarters of the load to be on a single circuit, nor would it ever be in any of the large problems with which we have to deal. Regulation under these circumstances is far better than the regulation of a three wire system with direct currents, under even a very much smaller variation of load between the two sides. In fact, these objections of regulation urged against the inter-connected polyphase systems are precisely the same objections which were raised in the early days of the three wire direct current system, and they have even less practical importance. It was said that the three wire system could not be regulated well; that it would not test well; that we were going to meet all kinds of difficulties in its use, and yet of the continuous current central station lighting I should say that not less than 85 per cent. is done by this badly regulated, difficult-to-manage system, and I think we are going to have the same experience with the alleged difficulties of inter-connected polyphase systems, whether two, three or more phases, it makes little difference in that respect.

Another interesting question with reference to these problems of distribution comes in the use of the rotary transformer. While like Prof. Forbes I would like very much to see a commutator converting alternating into direct currents, I am not quite as hopeful as he is about it. I do not doubt that it could be done for small currents for arc machines for example, just as we can build enormously high voltage direct current machines for small currents. When it comes to handling 1,000 kilowatts, I think that we will all be grayer and balder than we are now before we see it done by direct commutation. I do not think it is impossible, but the difficulties are pretty serious, whereas with the rotary transformer we have to-day a very efficient and effective means of securing direct currents from alternating, or still more easily from polyphase circuits. The rotary transformer such as we have had described is a machine which instead of having 85 to 90 per cent. of efficiency has from 80 to 95 or 96 per cent. of efficiency, owing to the connections in the armature, which were well explained by Dr. Duncan yesterday. It will be seen readily that the efficiency of the machine should be at least as high as the same one would give as an ordinary direct current generator, so that, although I earnestly hope we may have the commutator transformer, I think we will be very foolish to forget that we have now a thoroughly reliable and very simple piece of apparatus which will do the work and do it promptly, if necessary.

One of the most interesting questions which can well be raised is that one which Professor Forbes and Professor Rowland have been discussing this morning, that of step up and step down transformers versus machines giving the potential directly. We know what the step up transformer will do. We do not know yet what the 30,000 volt dynamo will do. Personally I am in-

clined to believe that if the machine is large enough 30,000 volts can be gotten from a stationary armature with a fair degree of success, but as the units get smaller the difficulties increase enormously and the ratio of copper to slot section in the armature gets worse and worse. For example, with a very large machine you might have the insulation of sufficient thickness to stand the voltage, which was very thick and yet occupied only a comparatively small portion of the entire amount of the space. As the machine gets smaller it gets harder and harder to build it for the high voltage, simply because the same amount of insulation is necessary for the given voltage, whether the output of the machine is 100 or 1,000 kilowatts or more. For extremely large machines I think that the high voltage can be met successfully, but for small machines, although it can still be done, it is, as Professor Forbes has very well said, at the expense of output.

Following the same course of reasoning, the difference between large and small machines as a commercial matter applies also to the periodicity. The bigger the machine the lower the periodicity which you can economically get out of it—a point which could readily be verified by any one who cares to test the machine. Of course there will be a lower limit that you cannot reach, but what I mean to say is that it is vastly easier to build a machine of 1,000 kilowatts for 50 periods than it is for 125 or 130.

Now, finally, I want to take up the question of the line, particularly with reference to very long transmissions such as have been mentioned by Professor Forbes. Incidentally I may remark that I am sorry to say that the position taken by the State of New York with reference to those Erie Canal experiments is not as hopeful as it was suggested. Instead of undertaking experiments for the benefit of the Commonwealth they have righteously granted permission to the various electrical companies to carry on experiments on the Erie Canal, provided that they do not disturb the surface, at their own expense. The State is unwilling even to furnish the canal boats, so that I think the probability of the immediate utilization of electric power on the Erie Canal is not so near as it might be. But with reference to the very long lines, I want to call attention to two important factors in success. In the first place, the inductance of the lines which was brought to our notice by Professor Silvanus P. Thompson yesterday, and in the second place the frequency. As regards the inductance of the line, it is a fact perhaps not generally known, but nevertheless a fact, that the tri-phase or the polyphase inter-connected systems for the same energy transmitted at the same voltage give a lower inductance total on the line, as, indeed, might be expected from the saving of copper. With the tri-phase inter-connected system, the inductance is a little less than $\frac{6}{10}$ of what it is on a single phase or independent circuit, multi-phase system. This has been verified by a number of investigators, and as a practical result it would appear that although induc-

ance is likely to cut a serious figure, we will get a great deal of relief by using dependent circuits. Fifty-seven per cent. is the exact ratio of the inductance on such a circuit compared with a single phase circuit carrying the same energy at the same voltage, so that in addition to saving copper we also save in inductance.

As regards the frequency, in order to keep down the inductance of the line under ordinary circumstances it is necessary to drop the frequency as the distance increases, and as Professor Rowland has well said, there is both an upper and a lower limit to the frequency. The upper limit would be less than the frequency that is now ordinarily used in electric lighting, 125 or 130 cycles, which would not be a good frequency to use over a transmission line for the reason of induction alone, even providing that the motors would do equally good work, which they will not. The lower limit is practically stated in the ordinary distribution plant by the necessities of incandescent lighting. Below 30 periods in fact, below perhaps 33 or 35 periods, to give a little margin of safety, incandescent lamps do not work well; they flicker and even before they begin to flicker perceptibly they produce an effect on the eye that is very disagreeable. In the same way the arc lamps, even with the best soft cored carbons at 40 or 50 cycles work quite well, the working being bettered by the use of a reflector to get all the light together. At 60 cycles even they give trouble with American hard carbons, so I think our practical lower limit of frequency is about 30 to 35 cycles. Anything below that should be employed for motors only, and I should consider it rather bad engineering to employ it even under those circumstances, inasmuch as it means making a special plant, and you can get excellent results at 30 to 35 cycles.

We must recognize however that there will be a distance at which we must lower the frequency below 33 cycles. That point will not be reached in more than two per cent., I should say, of the transmissions that we are likely to undertake in the next ten years, but when it does come we must be prepared to meet it squarely and lower our cycles or use direct currents. We can lower the cycles, and then when we reconvert, reconvert either to direct current or high cycles, and this process will probably have to be used at very long distances, such distances, for examples, as that from Niagara Falls to Albany.

As regards the keeping up of the line. I think it is a most serious problem that confronts the engineer in undertaking power transmission. In going out to California over the Santa Fe Railway last spring, I noticed that every bridge target from Kansas City to San Bernardino was perforated with from one to 25 bullet holes. The protection of a long line especially from malicious injury is a serious matter, and the worst of it is, that the underground conduit, in nine cases out of ten, from a commercial point of view is absolutely prohibitive; It would not pay. If we confine ourselves to underground conduits, then we will

never get any transmission work done in this country, at least; except in isolated cases, because the cost is enormous. For most of the overhead work we must employ bare wires, for insulating covering at 20,000 or 30,000 volts gives simply a false security. No insulation that is practicable to put upon wires will stand that voltage, and still remain intact through any period of time. The striking distance of a 20,000 volt current is something prodigious. We will have to put up the bare wires with the best danger signals that can be devised, even the skull and cross bones, if necessary, as they have on the Frankfurt line. The sooner we recognize that fact and face it, the easier it will be to accomplish power transmission. The conduit is all right in theory; it will secure practical uninterrupted operation of the lines, but as a commercial matter it is, in nearly every case that comes before us, prohibited. By conduit I mean a subway large enough for a man to go through and inspect, and any less means of putting the wires underground is objectionable, as Professor Forbes has well stated.

As regards distances which we are prepared to tackle to-day, I do not think any one of us would care to state a higher limit. Among the cases that practically come up are many more below 20 miles than above it, and rarely any above 50 miles. We have enough to keep us amply busy for the next decade in developing the powers which lie within 25 to 50 miles of the points at which it is desired to utilize them. Over such distances even to-day I do not think we need have any apprehensions whatever of success. For greater distances the problem resolves itself more into a commercial one than an electrical one. Given the price of coal high enough, and you could afford to take the power almost any distance, and if you are taking it any very great distance, it can be done with a tolerable degree of economy. Put enough money into the insulation, and success is not hard to attain. Save on the insulation, try to get along on as little as you can when you are trying to use 50,000 volts over 500 miles, and there will be trouble at once. The very long power installations are sure to come, I think, but they are rather likely to come slowly and to come probably when the amount of power to be transmitted is so great as to warrant extraordinary precautions in insulation and line inspection.

The Chairman then called on Mr. Charles S. Bradley to speak.

MR. CHARLES S. BRADLEY:—I think that I have very little, if anything, to add to the discussion. I am, of course, in some relationship with the General Electric Company, as is Dr. Bell, and he is more practical than I am, and this being a practical department, of course does not give me the opportunity it would if it were theoretical. There is one point that has come to my mind, that seemed desirable to suggest, and that is the fact that in interconnected polyphase systems the motors will help the equalization. Should there be any drop or inequality due to a difference

of load on the various branches, the motors being on all the interconnected circuits, especially if they are synchronous, will tend to help to keep the distribution and voltage even.

THE CHAIRMAN :—As we were obliged to limit the time of Mr. Charles P. Steinmetz yesterday, I take pleasure in again calling on him to continue the discussion.

MR. STEINMETZ :—Having listened to this very interesting discussion, I would like to make a few remarks on some points which have been brought out.

First, on the question of polyphase motors and the lag or retardation in the circuit caused by them. I have seen the results of a number of tests of motors of all sizes and kinds, and I have found that the lag in the circuit or the power factor cannot be expressed by simple expressions, but it is of a much more complicated nature. As before stated, I had occasion to check my tests directly by the results of practical observation and to find whether they agreed or not, and I found a complete agreement. If you have a polyphase motor, then the cosine of the angle of lag will vary. If the motor is loaded beyond a certain point, it comes to a stop and chokes the circuit. Now, how high the maximum point is, depends on the design of the motor evidently and upon its purpose. In some applications the motor should be able to stand a very large overload without getting out of step, but it will not run efficiently at light loads. Or the motor may be designed so that it will not carry so much of a load, but will have a very high power factor at light loads. Now, this function depends upon three distinct and different factors. The first is the self-induction of the armature; the second, the magnetization of the motor, and the third is the self-induction of the field. A certain *E. M. F.* is required to produce magnetization of the motor, and the *E. M. F.* induced will be at right angles to it. Hence the current in the armature lagging behind is at a certain angle, due to the self induction of the armature and the primary current, which, combined with the armature current, must give the resultant of the parallelogram. Now, the angle between the *E. M. F.* and the primary current or field current is due partly to the retardation in the secondary circuit. The secondary current lags behind the secondary *E. M. F.* The primary current lags behind the secondary current, and the primary *E. M. F.* advances in consequence of the self-induction, so you see the three factors constitute a lag. I cannot here go into mathematics, and I have not exactly calculated at what point the motor will fall out of step, but this is one point I wished to draw attention to.

A further point is that the self-induction of the armature is of much importance, being really one of the main factors which causes the angle of lag and the falling out of step. It has been attempted to provide means to get over this. The best means is to make the armature with very low self-induction. Furthermore, it has been proposed to surround the armature by a coil

which acts in the opposite direction and thereby destroying the magnetic circuit established by the armature current. This arrangement was used about three years ago by Mr. Eickemeyer to overcome the self-induction of an alternate current motor armature by surrounding the armature closely by a circuit excited by a current in opposite direction and of equal magnetizing force, with the current in the armature, and at that time I had occasion to make a very complete study of this method and found that it worked very well in reducing the self-induction of the armature, but does not annihilate it.

It was said yesterday that it would be interesting to compare the output of a machine used as a continuous current generator with its output as an alternating machine. I think we cannot do this any more than we can compare any two heterogeneous machines. The best way to build a continuous current machine is not the way to build an alternating current machine. The maximum output of the continuous current machine depends mainly upon the conditions at the commutator. The maximum output of the alternating machine depends upon the self-induction of the armature, and so they are dependent upon each other to a certain extent, but it may be that one machine will give a larger output as a continuous than as an alternating machine, and another may give a larger output as an alternating than as a continuous current machine.

Now, some things have been brought forward against the polyphase systems. I do not believe in the polyphase systems very much myself. I consider them only as a state of the art which we have to use now because the single phase system is not as yet developed sufficiently to place entire reliance in it, but I hope the polyphase system will be gone very soon and we will have the single phase; but as long as we have got it, we must study the unbalancing of the three phase or other polyphase systems which was so clearly explained by Professor Forbes. I have always found that a difficulty is a difficulty only as long as we do not understand it, but as soon as we understand what is going on, how it is caused, and we are able to calculate the effect, then we can design our machines so that the difficulty does not exist.

With regard to the high potential dynamo, we have differences of opinion. One says the best way is to build the alternating generator of very high potential—20,000 or 30,000 volts. The other says it is preferable to build the machine for low potential. I believe that if one tries to build our present alternating polyphase machines for anything more than 5,000 to 6,000 volts, he will fail badly. I think it is utterly hopeless to build our present forms of alternating machines for potentials like 20,000 volts, but on the other hand what can we do in the transformers to make them safe for 20,000 volts? Why can we not do the same for generators? The only question is dollars and cents, really. That is the test—which is the cheapest way? Is it cheaper to build

machines like the transformers designed to stand these very high potentials, or is it preferable to use transformers and to build the machine for a low potential? It may sound very hard to say that it is only a question of money, but a scheme may be as feasible as you like but it will never be carried out, if it is impracticable from a financial point of view.

In running the line you find the same condition again. You already have conduits running all over the country, oil pipes. Oil is a splendid insulator. Mains laid in oil pipes would be a very good way to have the best insulation. You could get rid of all the insulation and everything else, and still reduce the expense by a good deal. The self-induction is a very serious bugbear. It is a difficulty as long as you do not know how to calculate it and handle it and compensate and eliminate it, but as soon as you are able to do that the self-induction will change from being your enemy and become perhaps your best friend.

The President then gave the floor to Dr. N. S. Keith, who spoke as follows:

DR. KEITH:—I have very little to say except in the practical way. I have listened to this discussion upon polyphase systems. I find that they are essentially theoretical, and basinate upon *what is* to be done. I can refer to constant current transmission as a thing which has been accomplished, and which is in practice. Whether one will be preferable to the other I doubt, except in special instances where one is more applicable than the other.

As Professor Forbes spoke of the immense power of Niagara which he proposes to distribute over a greater portion of the State of New York, it occurred to me to say something to the Congress about the immense amount of power, which is available in the mountains of the Sierra Nevadas, which extend all the way from Alaska to Patagonia. In all those places we have an accumulation on the mountains of immense bodies of snow during the winter. As these snows melt in the spring they pass to the sea through many rivers, and the fall of water from these accumulations of snow before reaching the sea, or rather the level of the arable land below, is exceedingly great, as we understand it in this section of the country; varying from 7,000 to 10,000 feet in height. At almost regular intervals throughout the State of California, rivers run west and parallel to each other, and empty into the Sacramento and San Joaquin rivers, so discharging great quantities of water into the sea. This quantity varies, when unrestrained, from an exceeding large flow to a minimum flow at about this season, and later in the year. We have there a wet season and a dry season, the summer season being dry and the winter wet. During the winter rains fall in the lower countries and in the highlands, snows. Taking advantage of these facts, years ago extending back 40 years even ditch companies, as they are called, built canals, or ditches, from the higher sources of these rivers and carried them around the mountain sides, often-

times with great engineering ability, and expense. Those ditches exist to-day, and they are almost innumerable. They number into the hundreds; but there are many of them which have been combined under the ownership of companies. These companies pursue the plan of selling this water which they accumulate at the heads of the rivers, for various purposes, especially for power and for irrigation. But in order to use it for power, in the mining sections of the country more especially, they have to drop it from higher levels frequently into lower levels, in order to carry it to the point where it is desired. There are many places in the mountains, where power is requisite, which cannot be directly supplied by means of these water-falls, nor by water from the ditches. I will briefly recite the case of one ditch company, in order to show the immense amount of power which it has at its command and how small its availability is at present.

There is one company which has, at an elevation of 7,000 feet above the sea, reservoirs, both natural and artificial, with an accumulation of water which enables it to flow 5,000 miner's inches per day continually. The hydraulic engineer will tell you that, for a rough approximation one miner's inch, which equals about one and a half cubic feet per minute, falling a distance of 400 feet, will give one horse power. If we then use this inch, we may say—state its value as 400, multiply the 5,000 miner's inches of water by the 7,000 feet of fall, and divide by 400, we obtain 37,500 as the horse power, which this one ditch company, alone has available for power purposes. The water is not required for irrigation, except on a small scale area, until it reaches the lower level, nearly the level of the sea. By utilizing this water by electric power, and still selling as much power as the company now does by the direct application of water, it can have all this amount of water to sell at the lower levels at a price which is now 30 cents a miner's inch, per day. They sell the water for power purposes in the mountains at prices varying from 10 to 20 cents per miner's inch. By locating dynamos at the various falls from the level of one ditch to another, they can utilize all this power. But say that from losses by leakage and evaporation and from amount drawn out of irrigation at various places, this power is only 50,000. It gives the company, then, from three to four times as much power as they now can and do sell. From that, of course, there would be losses due to the generation of electricity and the transmission and distribution; but even then this comparatively small amount of power could be supplied at a far greater profit than is now done, with greater benefit to the miners of the state. Wood is getting very scarce. It is burned off in the most available sections, and cheaper power is desirable. Many mines are closed down simply because the power necessary to operate them is too costly. By arranging a system of this kind, either for the ditch companies, or for those who may become associated with them, the mining interests of this section of Cal-

ifornia and Nevada will be very much increased. We will then produce some of the gold which seems to be so desirable to increase our currency.

The Chairman then called on Mr. Herman Lemp, of Lynn, Mass.:

MR. LEMP:—I am afraid I have fallen into Section A this morning, and I ask the indulgence of this section if I follow the precepts of Section C.

The subject under discussion is one of great importance, and with the exception of the very interesting paper on Ocean Telephony by Professor Silvanus P. Thompson, nothing that I have had the pleasure of listening to has been of more practical value to me than the debate on the problem of transmission of energy. I am connected with a concern which is in a great measure dependent upon the system or systems through which the mechanical energy is brought to the consumer to be utilized and transformed into the particular form required for his business. I fully agree with Professor Silvanus P. Thompson that the simplest system is the best, and that it is far better to use more complicated methods in individual applications, even at the expense of economy, than to make the whole system a complicated one for the sake of an alleged economy or beauty of a new scheme. Whatever, therefore, may be the system of the future, we will have to meet it, and the few words I am going to say on the subject within the allotted time limit of our honorable chairman, are in response to a question propounded by Dr. Duncan, and which I have not heard answered as yet.

Dr. Duncan has asked the question, can any one having had practical experience with rotary transformers of the single winding type state how much more energy can be transmitted electrically through such a transformer as compared with the amount transmitted mechanically when it is used as a motor pure and simple. While these are not the exact words used by Dr. Duncan, I think they express his meaning, and hope Dr. Duncan will correct me if I am mistaken.

Before I answer this question I will briefly state the circumstances that led me to use the rotary transformer and under what conditions it is used practically.

While commercially introducing the Thomson electric welding process, we were confronted by the great first cost of machinery as one which seriously appeals to the pocket book of our would-be customer. Electric welding demands considerable power, it is true generally that it is for a limited time only, but it must have the power when needed just as a street car cannot limit itself in this country to the seating capacity as it is done in Paris. Our customer must be able to burn his specimen to be welded all to pieces if need be, with bad or good contact. But our customer does not always have the power to spare, and if he has to get special engines and boilers he must provide them of a larger size

than it would be necessary if the generator could be worked on a constant load factor. Hence the great first cost of a welding plant, and I may add that all of you who need steam power know that the engine to give it, must be sufficiently large for the maximum power required, that even with a fly wheel of ordinary dimensions there is little elasticity in a steam engine. You exceed its capacity and it comes to a stop. Not so with an electric motor. There is great elasticity in an electric motor. You overload it and if the fuse stands it the motors generally will give you for a short period 50 or even 100 per cent. more than its rated capacity.

This suggests the following: Five hundred volt power circuits of the continuous type are being erected all over the United States for street car work. Our standard in welding requires a primary voltage of 300 volts alternating. Now, is there no way by means of which we can get one current from the other? The motor-dynamo with two separate windings was thought of, and in a happy moment the idea suggested itself to me to connect two points at 180° apart on the commutator of a two pole, 500 volt motor with two collecting rings, and construct, as it were, a revolving pole changer with self-induction to prevent sparking. I had for a moment the presumption to congratulate myself upon a new and practical scheme, but only a few days later I found it to be one of the reinvented foreign inventions alluded to before by some of my learned friends, and had I understood better the almost classical book on dynamo-electric machinery of our esteemed Prof. Silvanus P. Thompson, I would have been wiser to start with.

But returning to our subject. Here was a beautiful chance for using the rotary transformer, and our practical results have demonstrated beyond a doubt its usefulness.

You will perceive that the average *e. m. f.* of an alternating circuit whose maximum is 500 is approximately 345 volts, and inasmuch as our standard voltage for indirect welding requires 300, the additional 45 volts will be used for drop in the conductors, etc.

Now, taking up the question of Dr. Duncan, I will state that if the load in the alternating circuit consists of translating devices without self-induction, and if also the field magnets of the motor are laminated, 130 per cent. of electrical energy can be transmitted through such a rotary transformer taking its ordinary output as a motor at 100 per cent. The lamination of the field poles I consider not absolutely necessary, but expedient to prevent heating of the frame through reaction of armature current not practically subdivided in two.

A self-inductive load, as found with welding apparatus, causes increase amperage for a given energy, and its immediate ill effect is to cause the armature to race, which, however, has been corrected by a compound wound field. Since no belt is used for transmitting or receiving power, there is no objection to running

the rotary transformer at a higher speed than is usual with armatures. In this way the output is increased in the ratio of the speed, which compensates for the loss in output occasioned by self-inductive loads. A practical application of this rotary transformer has now been in use for the past year, commercially only for about three months, for the purpose of welding street car rails to each other in the street. The machinery consists of a four-pole rotary transformer nominally 100 kilowatts, actually giving 150 kilowatts. It is compound wound and connected in the usual way to the trolley circuit. The alternating current is conducted to a large transformer, reducing the potential to three volts, and proportionally increased current. This plant has been continually working for three months, day and night, except Sunday, transmitting from 108 to 150 kilowatts, used for welding sections varying from 5 to 12 square inches. A full description of this apparatus I reserve for a paper to be delivered to the Institute at a later date.

THE CHAIRMAN:—We should like to hear again from Mr. W. F. C. Hasson, of San Francisco.

MR. HASSON:—I came East for information on long distance transmission, and I have a great variety of plans to take back with me to think over, and the diversity of them is very interesting, at least. I was going to tell you a little more about California myself, but that is rendered unnecessary by one of the late speakers.

In the East you have Niagara, but there is no waterfall of any particular importance aside from that. Water power is not so essential in the East because coal is not so dear as it is with us. The question of power transmission in California is a very serious one. It is absolutely essential to us for the reasons that have been given. In many districts there, power costs from \$150 to \$300 per horse power per annum, which renders manufacturing and the working of mines impossible, and with us it is not the question of the three-phase or two-phase or single-phase. It is any system that will meet the requirements, and these requirements, briefly stated and broadly divided over the entire country there, are first to operate mining districts; that is, power to run mills and stamps; machinery that will run day and night, week in and week out for months at a time. Second, power to run hoists; power to run pumps, which depends upon circumstances altogether, and, finally, power for lights, which, of course, is a varying load, and is really in those districts more of a luxury than a necessity. The second style of transmission is one for multifarious purposes for a number of cities, and that is, of course, to begin with, to furnish light; second, to furnish power, varying from one-quarter horse power to 500 horse power; third, for traction purposes. Now, for the purpose of transmitting comparatively large blocks of power for continuous operation, the single-phase, synchronous machinery appears admirably adapted

when properly constructed. The system does not, however, appear to be sufficiently flexible in the transmission of power for general purposes, and it appears to me from what I have heard here, that difficulties may occur on the line. Our modern engineers have solved this question practically in the development of the multiphase systems, as is shown to us in this exposition today. Looking at it from the point of a mechanical engineer, I have never seen a better machine in all of its mechanical details than that presented by the two-phase system, as displayed in the Electricity Building. Leaving out any other considerations, I was surprised, indeed, to hear it said yesterday by one of the eminent authorities, that the multiphase system was complex. I fail to see it. It appears to me admirable in its simplicity. The mere fact that by a single system, and by such easy means, power may be generated and used for such a variety of purposes, establishes its claim to simplicity beyond peradventure. I can only think that this eminent authority has confounded flexibility with complexity.

I have no fault to find with the systems proposed nor with the engineers who are doing their best to promote them. I can only say this one thing, that California is only waiting to see any one of these systems in successful commercial operation to adopt them to an enormous extent.

THE CHAIRMAN:—Owing to the lateness of the hour I will call upon Dr. Louis Duncan to close the discussion.

DR. DUNCAN:—Of the points brought out in the discussion it seems to me the most important are these: In the first place it has been shown that we are in a position to use two or three phase currents for a great many purposes. Mr. Scott's exhibit is promising as showing the purposes for which a two phase current can be used, and the same exhibit could have been made by the General Company with their apparatus.

Another point is whether the two or three phase system is the best and again, whether a single phase system will not supersede both, and it seems to me that the tendency of most of the foreign speakers and those of the American speakers who have had no practical experience is in the direction of a single phase system. Those of our American speakers who have had experience and have seen the advantages of the multiphase system are in favor of the multiphase system. The future can only tell which will be best, but certainly the multiphase system at present is the only practical system for general distribution. Another important question that was briefly taken up was the question of the number of periods, and I assure you that is not merely a theoretical one but a question of vast practical importance. This is true, I think, if we are going to use a comprehensive system; if we are going to do arc and incandescent lighting, as well as transmit power, then we must use about 50 periods per second. If we go down to very low periods we seriously complicate our

lighting, and as has been pointed out by Mr. Stilwell we put our multiphase motors at a disadvantage, greatly increasing the lagging current.

There are only two other matters which I wish to refer to. Mr. Steinmetz is speaking of a comparison between the output of continuous and alternating current machines so evidently misunderstood my question that I will only refer to Mr. Lemp's interpretation of the question, and the interesting answer which he gave.

Dr. Bell speaks of the difference in efficiency between motors supplied with sine and distorted waves of current, and seems to consider a loss of two or three per cent. as unimportant. As regards the loss of power I acknowledge that he is partly right, but as regards the output he is certainly wrong. To take an extreme case if the efficiency of a motor were 97 per cent. an additional loss of three per cent. would about halve its output.

Gentlemen, there is nothing to add to this discussion, but I think we all should be very grateful to the speakers, but especially those who have brought their practical experience here and given us the result of their studies.

THE CHAIRMAN :—Prior to adjournment I have been requested to read by title the name of a paper upon our programme. It is as follows: "A Note on the Variation of the Capacity of Insulated Wires with Temperature," by Professor Hermann S. Hering.

NOTE ON THE VARIATION OF CAPACITY OF INSULATED WIRES WITH TEMPERATURE.

BY HERMANN S. HERING, OF BALTIMORE, MD.

While making some tests of insulated wire for the Chicago Electric Company, I determined the capacity, resistance and electrification at various temperatures, and found that there was a decided variation of the capacity with the temperature of the wires. The samples of the wire tested were of No. 12 and 16 B. and S. guage covered with vulcanized rubber, the patented process of this Company, and invented by Mr. H. B. Cobb of Wilmington, Del. The radial thickness of the insulation was about $\frac{1}{16}$ inch. In two of the samples furnished, Nos. 3 and 5, the insulation was loose upon the wire, and in Nos. 1, 2 and 6 it was tight.

By referring to the diagram it will be observed that the curves are distinct and have a definite shape, and that there is a decided increase of capacity within the usual ranges of temperature met in practice.

All the tests were made in the same manner, with the same instruments and with all possible errors eliminated. Readings were taken after the wire had been charged 20 seconds.

The curves represented by solid lines were made during an immersion of the wire of from 5 to 10 days. Those represented by broken lines were made after an immersion of from 20 to 30 days. It will be observed also that the capacity increased slightly with the length of immersion, and that the capacity of samples Nos. 3 and 5, whose insulation was loose, not only had a

smaller capacity per mile than samples Nos. 1, 2 and 6, whose insulation was tight, but also had less variation within the same ranges of temperature.

The cause of this increase of capacity with the increase of temperature, is not easily explained unless the expansion and contraction of the insulation acts inwardly as well as outwardly, or if the specific inductive capacity of the vulcanized rubber changes

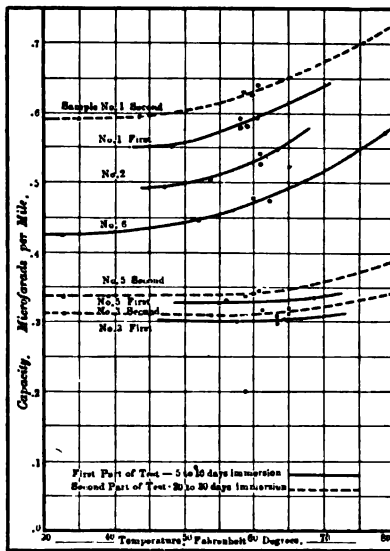

very materially within these variations of temperature but yet that does not offer an entire explanation. I thought at least that the results would be interesting, notwithstanding that I had no satisfactory theory with which to explain them.

On motion it was

Resolved, That a vote of thanks be tendered to our Chairman for the impartial and good natured way in which he has performed his duties as Chairman.

This resolution being carried unanimously, on motion, the meeting adjourned sine die.

THE TESLA MECHANICAL AND ELECTRICAL OSCILLATORS.*

On the evening of Friday, August 25, Mr. Tesla delivered a lecture on his mechanical and electrical oscillators, before the members of the Electrical Congress, in the hall adjoining the Agricultural Building, at the World's Fair Grounds. Besides the apparatus in the room, he employed an air compressor, which was driven by an electric motor.

Mr. Tesla was introduced by Dr. Elisha Gray, and began by stating that the problem he had set out to solve was to construct, first, a mechanism which would produce oscillations of a perfectly constant period independent of the pressure of steam or air applied, within the widest limits, and also independent of frictional losses and load. Secondly, to produce electric currents of a perfectly constant period independently of the working conditions, and to produce these currents with mechanism which should be reliable and positive in its action without resorting to spark gaps and breaks. This he successfully accomplished in his apparatus, and with this apparatus, now, scientific men will be provided with the necessaries for carrying on investigations with alternating currents with great precision. These two inventions Mr. Tesla called, quite appropriately, a mechanical and an electrical oscillator, respectively.

The former is substantially constructed in the following way. There is a piston in a cylinder made to reciprocate automatically by proper dispositions of parts, similar to a reciprocating tool. Mr. Tesla pointed out that he had done a great deal of work in

* Reprinted from "The Inventions, Researches and Writings of Nikola Tesla." By T. C. Martin.

perfecting his apparatus so that it would work efficiently at such high frequency of reciprocation as he contemplated, but he did not dwell on the many difficulties encountered. He exhibited, however, the pieces of a steel arbor which had been actually torn apart while vibrating against a minute air cushion.

With the piston above referred to there is associated in one of his models in an independent chamber an air spring, or dash pot, or else he obtains the spring within the chambers of the oscillator itself. To appreciate the beauty of this it is only necessary to say that in that disposition, as he showed it, no matter what the rigidity of the spring and no matter what the weight of the moving parts, in other words, no matter what the period of vibrations, the vibrations of the spring are always isochronous with the applied pressure. Owing to this, the results obtained with these vibrations are truly wonderful. Mr. Tesla provides for an air spring of tremendous rigidity, and he is enabled to vibrate big weights at an enormous rate, considering the inertia, owing to the recoil of the spring. Thus, for instance, in one of these experiments, he vibrates a weight of approximately 20 pounds at the rate of about 80 per second and with a stroke of about $\frac{7}{8}$ inch, but by shortening the stroke the weight could be vibrated many hundred times, and has been, in other experiments.

To start the vibrations, a powerful blow is struck, but the adjustment can be so made that only a minute effort is required to start, and, even without any special provision, it will start by merely turning on the pressure suddenly. The vibration being, of course, isochronous, any change of pressure merely produces a shortening or lengthening of the stroke. Mr. Tesla showed a number of very clear drawings, illustrating the construction of the apparatus from which its working was plainly discernible. Special provisions are made so as to equalize the pressure within the dash pot and the outer atmosphere. For this purpose the inside chambers of the dash pot are arranged to communicate with the outer atmosphere so that no matter how the temperature of the enclosed air might vary, it still retains the same mean density as the outer atmosphere, and by this method a spring of constant rigidity is obtained. Now, of course, the pressure of the atmosphere may vary, and this would vary the rigidity of the spring, and consequently the period of vibration, and this feature constitutes one of the great beauties of the apparatus; for, as Mr. Tesla pointed out, this mechanical system acts exactly like a

string tightly stretched between two points, and with fixed nodes, so that slight changes of the tension do not in the least alter the period of oscillation.

The applications of such an apparatus are, of course, numerous and obvious. The first is, of course, to produce electric currents, and by a number of models and apparatus on the lecture platform, Mr. Tesla showed how this could be carried out in practice by combining an electric generator with his oscillator. He pointed out what conditions must be observed in order that the period of vibration of the electrical system might not disturb the mechanical oscillation in such a way as to alter the periodicity, but merely to shorten the stroke. He combines a condenser with a self-induction, and gives to the electrical system the same period as that at which the machine itself oscillates, so that both together then fall in step and electrical and mechanical resonance is obtained, and maintained absolutely unvaried.

Next he showed a model of a motor with delicate wheelwork, which was driven by these currents at a constant speed, no matter what the air pressure applied was, so that this motor could be employed as a clock. He also showed a clock so constructed that it could be attached to one of the oscillators, and would keep absolutely correct time. Another curious and interesting feature which Mr. Tesla pointed out was that, instead of controlling the motion of the reciprocating piston by means of a spring, so as to obtain isochronous vibration, he was actually able to control the mechanical motion by the natural vibration of the electro-magnetic system, and he said that the case was a very simple one, and was quite analogous to that of a pendulum. Thus, supposing we had a pendulum of great weight, preferably, which would be maintained in vibration by force, periodically applied; now that force, no matter how it might vary, although it would oscillate the pendulum, would have no control over its period.

Mr. Tesla also described a very interesting phenomenon which he illustrated by an experiment. By means of this new apparatus, he is able to produce an alternating current in which the *E. M. F.* of the impulses in one direction preponderates over that of those in the other, so that there is produced the effect of a direct current. In fact, he expressed the hope that these currents would be capable of application in many instances, serving as direct currents. The principle involved in this preponderat-

ing E. M. F. he explains in this way: Suppose a conductor is moved into the magnetic field and then suddenly withdrawn. If the current is not retarded, then the work performed will be a mere fractional one; but if the current is retarded, then the magnetic field acts as a spring. Imagine that the motion of the conductor is arrested by the current generated, and that at the instant when it stops to move into the field, there is still the maximum current flowing in the conductor; then this current will, according to Lenz's law, drive the conductor out of the field again, and if the conductor has no resistance, then it would leave the field with the velocity it entered it. Now it is clear that if, instead of simply depending on the current to drive the conductor out of the field, the mechanically applied force is so timed that it helps the conductor to get out of the field, then it might leave the field with higher velocity than it entered it, and thus one impulse is made to preponderate in E. M. F. over the other.

With a current of this nature, Mr. Tesla energized magnets strongly, and performed many interesting experiments bearing out the fact that one of the current impulses preponderates. Among them was one in which he attached to his oscillator a ring magnet with a small air gap between the poles. This magnet was oscillated up and down 80 times a second. A copper disk, when inserted within the air gap of the ring magnet, was brought into rapid rotation. Mr. Tesla remarked that this experiment also seemed to demonstrate that the lines of flow of current through a metallic mass are disturbed by the presence of a magnet in a manner quite independently of the so-called Hall effect. He showed also a very interesting method of making a connection with the oscillating magnet. This was accomplished by attaching to the magnet small insulated steel rods, and connecting to these rods the ends of the energizing coil. As the magnet was vibrated, stationary nodes were produced in the steel rods, and at these points the terminals of a direct current source were attached. Mr. Tesla also pointed out that one of the uses of currents, such as those produced in his apparatus, would be to select any given one of a number of devices connected to the same circuit by picking out the vibration by resonance. There is indeed little doubt that with Mr. Tesla's devices, harmonic and synchronous telegraphy will receive a fresh impetus, and vast possibilities are again opened up.

Mr. Tesla was very much elated over his latest achievements, and said that he hoped that in the hands of practical, as well as scientific men, the devices described by him would yield important results. He laid special stress on the facility now afforded for investigating the effect of mechanical vibration in all directions, and also showed that he had observed a number of facts in connection with iron cores.

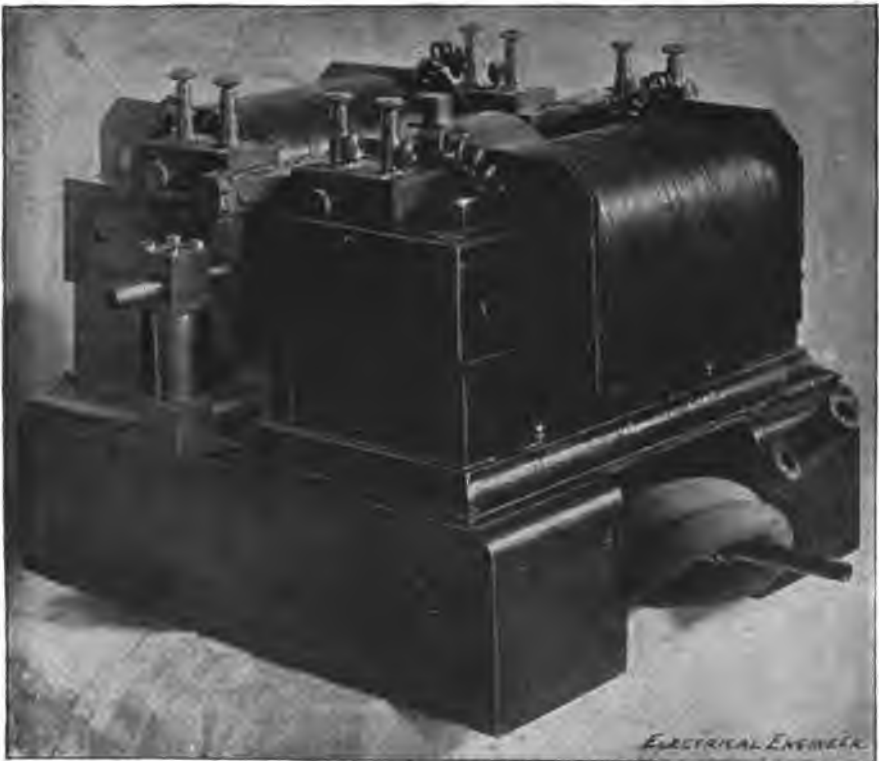

FIG. 1.

The engraving, Fig. 1, shows, in perspective, one of the forms of apparatus used by Mr. Tesla in his earlier investigations in this field of work, and its interior construction is made plain by the sectional view shown in Fig. 2. It will be noted that the piston *p* is fitted into the hollow of a cylinder *c* which is provided with channel ports *o o*, and *l*, extending all around the inside surface. In this particular apparatus there are two channels *o o*

for the outlet of the working fluid and one, *i*, for the inlet. The piston *p* is provided with two slots *s s'* at a carefully determined distance, one from the other. The tubes *t t* which are screwed into the holes drilled into the piston, establish communication between the slots *s s'* and chambers on each side of the piston, each of these chambers connecting with the slot which is remote from it. The piston *p* is screwed tightly on a shaft *a* which passes through fitting boxes at the end of the cylinder *c*. The boxes project to a carefully determined distance into the hollow of the cylinder *c*, thus determining the length of the stroke.

Surrounding the whole is a jacket *j*. This jacket acts chiefly to diminish the sound produced by the oscillator and as a jacket when

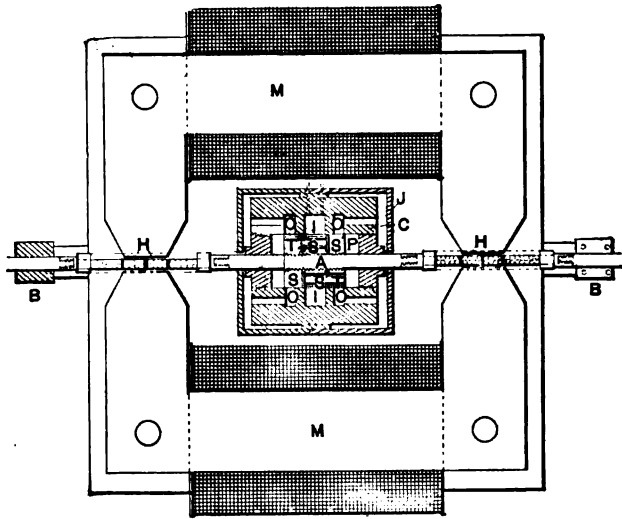

FIG. 2.

the oscillator is driven by steam, in which case a somewhat different arrangement of the magnets is employed. The apparatus here illustrated was intended for demonstration purposes, air being used as most convenient for this purpose.

A magnetic frame *m. m.* is fastened so as to closely surround the oscillator and is provided with energizing coils which establish two strong magnetic fields on opposite sides. The magnetic frame is made up of thin sheet iron. In the intensely concentrated field thus produced, there are arranged two pair of coils *h h* supported in metallic frames which are screwed on the shaft *a* of

the piston and have additional bearings in the boxes *B B* on each side. The whole is mounted on a metallic base resting on two wooden blocks.

The operation of the device is as follows: The working fluid being admitted through an inlet pipe to the slot *i* and the piston being supposed to be in the position indicated, it is sufficient, though not necessary, to give a gentle tap on one of the shaft ends protruding from the boxes *B*. Assume that the motion imparted be such as to move the piston to the left (when looking at the diagram) then the air rushes through the slot *s'* and tube *r* into the chamber to the left. The pressure now drives the piston towards the right and owing to its inertia, it overshoots the position of equilibrium and allows the air to rush through the slot *s* and tube *r* into the chamber to the right, while the communication to the left hand chamber is cut off, the air of the latter chamber escaping through the outlet *o* on the left. On the return stroke a similar operation takes place on the right hand side. This oscillation is maintained continuously and the apparatus performs vibrations from a scarcely perceptible quiver amounting to more than $\frac{1}{16}$ of an inch, up to the vibrations of a little over $\frac{3}{8}$ of an inch, according to the air pressure and load. It is indeed interesting to see how an incandescent lamp is kept burning with the apparatus showing a scarcely perceptible quiver.

To perfect the mechanical part of the apparatus so that oscillations are maintained economically was one thing, and Mr. Tesla hinted in his lecture at the great difficulties he had first encountered to accomplish this. But to produce oscillations which would be of constant period was another task of no mean proportions. As already pointed out, Mr. Tesla obtains the constancy of period in three distinct ways. Thus, he provides properly calculated chambers, as in the case illustrated, in the oscillator itself; or he associates with the oscillator an air spring of constant resilience. But the most interesting of all, perhaps, is the maintenance of the constancy of oscillation by the reaction of the electromagnetic part of the combination. Mr. Tesla winds his coils, by preference, for high tension and associates with them a condenser, making the natural period of the combination fairly approximating to the average period at which the piston would oscillate without any particular provision being made for the constancy of period under varying pressure and load. As the piston with the coils is perfectly free to move, it is extremely susceptible to the influence of the natural vibra-

tion set up in the circuits of the coils $\pi \pi$. The mechanical efficiency of the apparatus is very high owing to the fact that friction is reduced to a minimum and the weights which are moved are small; the output of the oscillator is therefore a very large one.

Theoretically considered, when the various advantages which Mr. Tesla holds out are examined, it is surprising, considering the simplicity of the arrangement, that nothing was done in this direction before. No doubt many inventors, at one time or other, have entertained the idea of generating currents by attaching a coil or a magnetic core to the piston of a steam engine, or generating currents by the vibrations of a tuning fork, or similar devices, but the disadvantages of such arrangements from an engineering standpoint must be obvious. Mr. Tesla, however, in the introductory remarks of his lecture, pointed out how by a series of conclusions he was driven to take up this new line of work by the necessity of producing currents of constant period and as a result of his endeavors to maintain electrical oscillation in the most simple and economical manner.

INTERNATIONAL ELECTRICAL CONGRESS BANQUET IN HONOR OF
THE FOREIGN OFFICIAL DELEGATES, GIVEN BY THE ELEC-
TRICIANS OF AMERICA, CHICAGO, THURSDAY EVENING, AUGUST
24, 1893.

FOREIGN OFFICIAL DELEGATES.

ENGLAND.

Preece, W. H.
Ayrton, Prof. W. E.
Thompson, Prof. S. P.
Siemens, Alex.

FRANCE.

Mascart, M.
Hospitalier, M.
Violle, M.
De la Touanne, M.

GERMANY.

Helmholtz, Dr. H. von
Lummer, Dr.

SWITZERLAND.

Palaz, Dr. A.
Thury, M.

ITALY.

Ferraris, Prof. Galileo

MEXICO.

Chavez, Senor Don A. M.

The other gentlemen present were as follows :

Ayer, Jas. I.	Baker, W. E.	Degenhardt, F. E.
Ayres, Brown	Beach, F. G.	Dunn, Gano S.
Anderson, W. E.	Braddell, A. E.	Dee, Jas. R.
Abbott, A. V.	Bayles, R. N.	Dee, Thos. S.
Badt, F. B.	Budde, Dr. E.	Dolbear, A. E.
Bliss, G. H.	Cutter, George	Emery, C. E.
Bedell, Frederick	Clowry, R. C.	Edison, Thomas A.
Burnett, Douglass	Cross, Chas. R.	Eickemeyer, R.
Baker, Jr., C. O.	Crocker, Francis B.	Foster, H. A.
Bernard, E. G.	Cuttriss, Chas.	Flood, S. D.
Baldwin, O. H.	Collins, W. Forman	Feuszner, Dr. Carl
Bradley, Chas. S.	Carpmael, C.	Frick, Otto
Brown, Chas. E.	Carhart, H. S.	Ferguson, L. A.
Blake, Eli	Deland, Fred.	Gray, Elisha
Babo, Alex. von	Doremus, Chas. A.	Guerreiro, J. V. M.

Hornsby, J. Allen	Metcalf, Geo. R.	Stubbs, Will C.
Hamilton, Geo. A.	McKinlock, Geo. A.	Smith, Jesse M.
Hayes, H. V.	McFarland, G. E.	Shrader, Wm.
Houston, Edwin J.	Manning, H. D.	Summers, C. H.
Horne, F. W.	Nichols, E. L.	Shippy, Henry L.
Heinrich, R. O.	Olivette, Camillo	Spencer, Lieut. E. J.
Hewitt, Edw. R.	O'Dea, M.	Sperry, Elmer A.
Heaviside, A. W.	Otis, N. P.	Steinmetz, C. P.
Heinrichs, Dr. G.	Owens, R. B.	Sunny, B. E.
Higman, A. E.	O'Hara, J. B.	Smith, Francis H.
Insull, Samuel	Pollak, C.	Summers, L. L.
Jones, F. W.	Perry, Nelson W.	Short, Sidney H.
Johnston, W. J.	Pope, Ralph W.	Schulze-Berge, F.
Jones, A. J.	Phelps, Geo. M.	Terry, F. S.
Khotinsky, A. de	Perkins, F. C.	Tischendoerfer, F. W.
Keith, N. S.	Page, Chas. T.	Thomson, Elihu
Kennelly, A. E.	Perry, D. P.	Thomas, Benj. F.
Lockwood, T. D.	Patterson, G. W. Jr.	Weston, Edward
Lobach, Dr. Walter	Powers, E. L.	Wetzler, Joseph
Lemp, Hermann	Reed, Henry A.	Voit, Dr.
Lawry, C. D.	Richardson, R. E.	Walmsley, R. M.
Lemstrom, Selim	Rogers, H. R.	Wilson, C. H.
McIntyre, C. H.	Rotch, A. L.	Weeks, Edw. R.
Macfarlane, Alex.	Regua, Mr. Harry L.	Weeks, Raymond L.
Mendenhall, T. C.	Rowland, Henry A.	Wheeler, S. S.

Dr. Elisha Gray, the Chairman of the Congress, who had made the arrangements for the banquet which were admirably carried out, acted as toastmaster.

After the dinner had been served Dr. Gray made a few remarks and then called upon the Honorary President, Dr. von Helmholtz, to respond to the toast, "The International Electrical Congress." Concluding his brief address Dr. von Helmholtz said:

"We Europeans have come over here with the feelings of a good father, rejoicing in the success of his children to which he himself could not attain. Europe is too narrow for the splendid march of electrical progress, and America has grandly performed the task set before it. We see in you the result of better conditions and prospects than we have enjoyed, and we rejoice with you in your remarkable advancement. Gentlemen, I drink my glass to the great American Nation!"

The next toast was "Our Guests, the Foreign Official Delegates," which was responded to by Mr. W. H. Preece, Mr. Mascart and Prof. Ferraris, each speaking in his native language.

Speeches were also made by Messrs. Ayrtton, Houston, Thompson, Mendenhall, Lummer, Thomson, Carhart, Rowland and Lockwood.

FINAL GENERAL MEETING
OF
THE INTERNATIONAL ELECTRICAL CONGRESS.

FRIDAY, AUGUST 25TH, 1893, AT 3 P. M.

Dr. Elisha Gray, Chairman of the Congress, presided.

THE CHAIRMAN:—If you will please come to order we will now have the pleasure of listening to the report of the Chamber of Delegates.

Prof. E. L. Nichols, Secretary of the Chamber of Official Delegates, then gave the report which is contained in full on page 20.

The Chairman then called on Mr. William H. Preece, of London, who desired to make an announcement.

MR. PREECE:—The announcement I have to make is an extremely simple one. As President of the Institution of Electrical Engineers of England it is my wish to invite the members of this the Institute of Electrical Engineers of America to meet me at Victoria House in the Grounds of the World's Fair, especially as the American Institute has done me the great honor to make me an honorary member, there being only two honorary members, therefore I am one of their number. I have experienced the great difficulty that the addresses of the members of the American Institute and the members of the congress have not been very carefully kept. Therefore, I invite all the members of this congress whether they are the members of the American Institute of Electrical Engineers or not, to allow me to have the pleasure of receiving them to-morrow afternoon, between the hours of five and seven o'clock in my present British Home, Victoria House, World's Fair Grounds.

THE CHAIRMAN:—Mr. Pope has some announcements to make.

Mr. Pope then made announcements as to Mr. Tesla's lecture at eight o'clock that evening at the Agricultural Hall, in the World's Fair Grounds. He also stated that the members of the congress are invited to visit the exhibits of the Bell Telephone

Company, Western Electric Company, General Electric Company, Westinghouse Manufacturing Company and others at the World's Fair.

THE CHAIRMAN:—As we will have no other opportunity I would suggest that a vote of thanks be given to these various persons who have already extended to us many privileges and desire to do even more for us to-morrow.

It was resolved that the various parties who extended those courtesies be tendered a vote of thanks.

THE CHAIRMAN:—I now call upon Dr. H. von Helmholtz to address the Congress.

DR. VON HELMHOLTZ spoke as follows:—Ladies and gentlemen, we have performed a work which I hope will have good fruits for all future time in creating a congruity of the electrical associations of all nations so that scientific and industrial men can understand each other in the simplest and best way. Now, it was a rather hard piece of work in these hot days in the continual meetings of the delegates and members of the congress; and he who has had the greatest part of these exertions and work on this occasion is our chairman, Elisha Gray, and therefore, I want you to extend to him your thankfulness for this work he has done.

M. MASCART seconded the motion, speaking in his native tongue.

MR. PREECE:—It is my duty, ladies and gentlemen, to put this proposition to the meeting, it is that a vote of thanks be extended to our chairman, Dr. Gray. Those in favor of this proposition will kindly say aye. I see there is no use to ask for the contrary vote.

The motion is carried unanimously.

PROF. ELISHA GRAY spoke as follows:—Gentlemen, I cannot tell you how grateful this is to me. I have worked for the last two years in organizing this congress under many difficulties, and these difficulties have continued right up to the present moment. These steam locomotives outside do not even give us a chance to express ourselves. Now before we leave I want to thank the members of this congress for the good part you have taken in the difficulties under which you have had to labor and I have had to labor. I think upon the whole the congress has been very successful, and I trust that you will go away feeling this to be true, and that you will think of us kindly. And you gentlemen, who come from foreign shores, when you go home and look back do not think only of the smoke and noise and high buildings but think of us over here as having warm hearts. (Applause.) I wish you well and pray that you will have a smooth voyage and a warm, hearty welcome when you return to your homes and dear ones.

Now, gentlemen, this closes the work of the International Electrical Congress at Chicago in 1893.

I now declare the same adjourned.

ERRATA.

[Part of discussion on "Ocean Telephony" to be inserted on page 161, 25 lines from top.]

MR. A. E. KENNELLY, of Orange, N. J.:—There are two known methods of neutralizing the influence of electrostatic capacity by inductance in periodic current circuits. One is by placing the inductance in series with the capacity; the other is by placing it in parallel with the capacity. The method suggested in the paper we have just heard with so much interest is the second. There can, however, be only one particular frequency for sinusoidal current waves, at which, a given combination of inductance and resistance inserted in derived circuits as proposed, can neutralize the electrostatic capacity of the cable. At all other frequencies the compensation can only be imperfect, the signals transmitted distorted, and their speed of legible transmission reduced. Just how far the improvement in speed would be effected on the average; or, taking the opposite standpoint, over what range of frequency above and below the single frequency of complete compensation, a material advantage in freedom from distortion would be obtained, is, of course, an intricate question that can only be attacked in detail for each case.

Mr. Oliver Heaviside has pointed out that it is theoretically possible to have a submarine cable in which no distortion exists at any frequency. In this "distortionless circuit," as he calls it, an indefinitely high rate of signalling, and perfect telephonic transmission could be obtained. He has shown that the electrostatic capacity can be neutralized by the insertion of inductance directly in the conductor circuit, instead of in derived circuits; *i. e.*, by the first of the two above mentioned methods, instead of by the second. Unfortunately, however, for constructive and commercial reasons, we are yet unable to practically produce a submarine cable in which the proper proportions of resistance, inductance, leakage and capacity coexist in conformity with the requirements of a distortionless circuit.

It is a grave question whether, with our present skill and knowledge, we could localize breaks or discontinuities in a Heaviside distortionless cable, or in such a cable as Professor Thompson here advocates, which would be distortionless at a single harmonic frequency. But if the difficulties in making such cables could be overcome, we may surely hope that the difficulties in their repair might not be insuperable.

ERRATA.—Continued.

-
- Page 6, 18 lines from top, read On for one.
- “ 16, 5 “ “ bottom, “ appointment for appointment.
- “ 105, 2 “ “ top, “ Dr. J. Sahulka for Dr. T. Sahulka.
- “ 141, 9 “ “ bottom, “ whether for that.
- “ 157, 14 “ “ top, “ Dr. Silvanus for Dr. Sylvanus.
- “ 210, 16 “ “ bottom, “ I should like to ask one question in regard to the necessary frequency of calibration of the instrument, that is, supposing it is set up and used, how often is calibration necessary ?
- Page 353, 25 lines from bottom, read Schulze for Shulze.
- “ “ 18 “ “ “ “ “ “ “ “
- “ “ 3 “ “ “ “ “ “ “ “
- “ 466, 17 “ “ top, “ Chairman for President.

